



YAMAHA

252+1 motorcycle

YFS200 (U-A)

SERVICE MANUAL

**YFS200U
SERVICE MANUAL**

**© 1987 by Yamaha Motor Corporation, U.S.A.
1st Edition, October 1987**

**All rights reserved. Any reprinting or
unauthorized use without the written
permission of Yamaha Motor Corporation, U.S.A.
is expressly prohibited.**

**Printed in U.S.A.
P/N LIT-11616-06-41**

NOTICE

This manual was written by the Yamaha Motor Company primarily for use by Yamaha dealers and their qualified mechanics. It is not possible to put an entire mechanic's education into one manual, so it is assumed that persons using this book to perform maintenance and repairs on Yamaha machines have a basic understanding of the mechanical concepts and procedures inherent in machine repair technology. Without such knowledge, attempted repairs or service to this model may render it unfit to use and/or unsafe.

Yamaha Motor Company, Ltd. is continually striving to improve all models manufactured by Yamaha. Modifications and significant changes in specifications or procedures will be forwarded to all Authorized Yamaha dealers and will, where applicable, appear in future editions of this manual.

TECHNICAL PUBLICATIONS
SERVICE DIVISION
MOTORCYCLE OPERATIONS
YAMAHA MOTOR CO., LTD.

HOW TO USE THIS MANUAL

PARTICULARLY IMPORTANT INFORMATION

This material is distinguished by the following notation.

NOTE: A **NOTE** provides key information to make procedures easier or clearer.

CAUTION:

A **CAUTION** indicates special procedures that must be followed to avoid damage to the machine.

WARNING:

A **WARNING** indicates special procedures that must be followed to avoid injury to a machine operator or person inspecting or repairing the machine.

MANUAL FORMAT























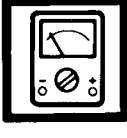

All of the procedures in this manual are organized in a sequential, step-by-step format. The information has been compiled to provide the mechanic with an easy to read, handy reference that contains comprehensive explanations of all disassembly, repair, assembly, and inspection operations.

In this revised format, the condition of a faulty component will precede an arrow symbol and the course of action required will follow the symbol, e.g.,

- Bearings
Pitting/Damage → Replace.

EXPLODED DIAGRAM

Each chapter provides exploded diagrams before each disassembly section for ease in identifying correct disassembly and assembly procedures.

① GEN INFO 	② SPEC 	
③ INSP ADJ 	④ ENG 	
⑤ COOL 	⑥ CARB 	
⑦ DRIV 	⑧ CHAS 	
⑨ ELEC 	⑩ TRBL SHTG ? 	
⑪ 	⑫ 	
⑬ 	⑭ 	
⑮ 	⑯ 	
⑰ 	⑱ 	
⑲ 	⑳ 	㉑ 
㉒ 	㉓ 	㉔ 

ILLUSTRATED SYMBOLS (Refer to the illustration)

Illustrated symbols ① to ⑩ are designed as thumb tabs to indicate the chapter's number and content.

- ① General information
- ② Specifications
- ③ Periodic inspection and adjustment
- ④ Engine
- ⑤ Cooling system
- ⑥ Carburetion
- ⑦ Drive train
- ⑧ Chassis
- ⑨ Electrical
- ⑩ Troubleshooting







Illustrated symbols ⑪ to ⑰ are used to identify the specifications appearing in the text.

- ⑪ Filling fluid
- ⑫ Lubricant
- ⑬ Special tool
- ⑭ Tightening
- ⑮ Wear limit, clearance
- ⑯ Engine speed
- ⑰ Ω , V, A

Illustrated symbols ⑱ to ⑳ in the exploded diagram indicate grade of lubricant and location of lubrication point.

- ⑱ Apply locking agent (LOCTITE®)
- ⑲ Apply engine oil
- ⑳ Apply gear oil
- ㉑ Apply molybdenum disulfide oil
- ㉒ Apply wheel bearing grease
- ㉓ Apply lightweight lithium-soap base grease
- ㉔ Apply molybdenum disulfide grease

INDEX

GENERAL INFORMATION	
	GEN INFO 1
SPECIFICATIONS	
	SPEC 2
PERIODIC INSPECTION AND ADJUSTMENT	
	INSP ADJ 3
ENGINE OVERHAUL	
	ENG 4
CARBURETION	
	CARB 5
CHASSIS	
	CHAS 6
ELECTRICAL	
	ELEC 7
TROUBLESHOOTING	?
	TRBL SHTG 8

CONTENTS

CHAPTER 1. GENERAL INFORMATION

MACHINE IDENTIFICATION	1-1
VEHICLE IDENTIFICATION NUMBER (FOR USA AND CANADA)	1-1
FRAME SERIAL NUMBER (EXCEPT FOR USA AND CANADA)	1-1
ENGINE SERIAL NUMBER	1-1
IMPORTANT INFORMATION	1-2
PREPARATION FOR REMOVAL AND DISASSEMBLY	1-2
ALL REPLACEMENT PARTS	1-2
GASKETS, OIL SEALS, AND O-RINGS	1-2
LOCK WASHERS/PLATES AND COTTER PINS	1-3
BEARINGS AND OIL SEALS	1-3
CIRCLIPS	1-3
SPECIAL TOOLS	1-4
FOR TUNE-UP	1-4
FOR ENGINE SERVICE	1-4
FOR CHASSIS SERVICE	1-6
FOR ELECTRICAL COMPONENTS	1-6

CHAPTER 2. SPECIFICATIONS

GENERAL SPECIFICATIONS	2-1
MAINTENANCE SPECIFICATIONS	2-4
ENGINE	2-4
CHASSIS	2-8
ELECTRICAL	2-11
GENERAL TORQUE SPECIFICATIONS	2-13
DEFINITION OF UNITS	2-13
LUBRICATION POINTS AND LUBRICANT TYPE	2-14
ENGINE	2-14
CHASSIS	2-14
CABLE ROUTING	2-16

CHAPTER 3. PERIODIC INSPECTION AND ADJUSTMENT

INTRODUCTION	3-1
PERIODIC MAINTENANCE/LUBRICATION	3-1
ENGINE	3-2
IDLE SPEED ADJUSTMENT	3-2
THROTTLE CABLE FREE PLAY ADJUSTMENT	3-3
SPEED LIMITER ADJUSTMENT	3-3
AUTOLUBE PUMP AIR BLEEDING	3-4
SPARK PLUG INSPECTION	3-6
IGNITION TIMING CHECK	3-7
ENGINE OIL LEVEL INSPECTION	3-7
TRANSMISSION OIL LEVEL INSPECTION	3-8
TRANSMISSION OIL REPLACEMENT	3-9
CLUTCH ADJUSTMENT	3-10
AIR FILTER CLEANING	3-14
CARBURETOR JOINT INSPECTION	3-16
FUEL LINE INSPECTION	3-16
CRANKCASE VENTILATION HOSE INSPECTION	3-16
EXHAUST SYSTEM INSPECTION	3-18
ENGINE OIL LINE INSPECTION	3-18
CHASSIS	3-19
FRONT BRAKE ADJUSTMENT	3-19
PARKING BRAKE ADJUSTMENT	3-20
BRAKE PAD INSPECTION (REAR BRAKE)	3-20
BRAKE SHOE INSPECTION (FRONT BRAKE)	3-20
DRIVE CHAIN SLACK ADJUSTMENT	3-21
DRIVE CHAIN LUBRICATION	3-22
STEERING SYSTEM INSPECTION	3-22
TOE-IN ADJUSTMENT	3-23
FRONT SHOCK ABSORBER ADJUSTMENT	3-24
REAR SHOCK ABSORBER ADJUSTMENT	3-25
TIRE INSPECTION	3-26
WHEEL INSPECTION	3-28
CABLE INSPECTION AND LUBRICATION	3-29
LEVER AND PEDAL LUBRICATION	3-29
FRONT SUSPENSION LUBRICATION	3-29
STEERING COLUMN BUSHING LUBRICATION	3-30
ELECTRICAL	3-30
HEADLIGHT BEAM ADJUSTMENT	3-30
HEADLIGHT BULB REPLACEMENT	3-30
TAIL LIGHT REPLACEMENT	3-31



**GEN
INFO** **1**



SPEC **2**



**INSP
ADJ** **3**



ENG **4**



CARB **5**



CHAS **6**



ELEC **7**



**TRBL
SHTG** **8**







CHAPTER 4. ENGINE OVERHAUL

ENGINE REMOVAL	4-1
TRANSMISSION OIL	4-1
CARBURETOR	4-1
REED VALVE	4-1
SEAT AND FUEL TANK	4-1
LEAD	4-2
CABLE	4-2
HOSE	4-3
EXHAUST PIPE	4-4
DRIVE CHAIN	4-4
FOOTREST	4-5
ENGINE REMOVAL	4-5
ENGINE DISASSEMBLY	4-5
CYLINDER HEAD, CYLINDER AND PISTON	4-5
CLUTCH	4-7
PRIMARY DRIVE GEAR AND BALANCER GEAR	4-8
KICK AXLE	4-9
SHIFT SHAFT AND STOPPER LEVER	4-9
CDI MAGNETO	4-10
CRANKCASE (RIGHT)	4-11
SHIFTER, TRANSMISSION AND BALANCER	4-12
CRANKSHAFT	4-13
AUTOLUBE PUMP	4-14
INSPECTION AND REPAIR	4-14
CYLINDER HEAD	4-14
CYLINDER AND PISTON	4-15
PISTONRINGS	4-17
PISTON PIN AND BEARING	4-18
CLUTCH	4-18
PRIMARY DRIVE	4-20
TRANSMISSION AND SHIFTER	4-20
KICK STARTER	4-22
SHIFT SHAFT	4-23
AUTOLUBE PUMP	4-23
CRANKSHAFT	4-23
CRANKCASE	4-25
ENGINE ASSEMBLY AND ADJUSTMENT	4-26
AUTOLUBE PUMP	4-26
CRANKSHAFT	4-26
AUTOLUBE PUMP	4-27
CRANKSHAFT, PISTON AND BALANCER	4-28

BALANCER, TRANSMISSION AND SHIFTER	4-29
TRANSMISSION	4-30
SHIFTER	4-31
CRANKCASE (RIGHT)	4-32
CDI MAGNETO	4-33
STOPPER LEVER AND SHAFT	4-35
KICK AXLE	4-35
SHIFT SHAFT	4-36
KICK AXLE	4-37
PRIMARY DRIVE GEAR AND BALANCER GEAR	4-38
CLUTCH	4-39
CYLINDER HEAD, CYLINDER AND PISTON	4-43
CYLINDER HEAD AND CYLINDER	4-45
REMountING ENGINE	4-46

CHAPTER 5. CARBURETION

CARBURETOR	5-1
SECTIONAL VIEW	5-2
REMOVAL	5-3
DISASSEMBLY	5-4
INSPECTION	5-6
ASSEMBLY	5-7
INSTALLATION	5-9
FUEL LEVEL ADJUSTMENT	5-11
CARBURETOR SETTING CHANGE	5-12
REED VALVE	5-13
REMOVAL	5-14
DISASSEMBLY	5-14
INSPECTION	5-14
ASSEMBLY	5-15
INSTALLATION	5-16

	GEN INFO	1
	SPEC	2
	INSP ADJ	3
	ENG	4
	CARB	5
	CHAS	6
	ELEC	7
?		
TRBL SHTG		8

CHAPTER 6. CHASSIS

FRONT WHEEL AND FRONT BRAKE	6-1
REMOVAL	6-1
INSPECTION	6-3
INSTALLATION	6-6
REAR WHEEL AND REAR AXLE	6-9
REMOVAL	6-10
INSPECTION	6-13
INSTALLATION	6-15
REAR BRAKE	6-19
REMOVAL	6-20
INSPECTION	6-23
ASSEMBLY AND INSTALLATION	6-24
STEERING SYSTEM	6-28
REMOVAL	6-29
INSPECTION	6-32
INSTALLATION	6-34
FRONT SHOCK ABSORBER AND FRONT ARMS	6-38
REMOVAL	6-39
INSPECTION	6-41
INSTALLATION	6-42
REAR SHOCK ABSORBER AND SWINGARMS	6-45
HANDLING NOTES	6-46
NOTES ON DISPOSAL	6-46
REMOVAL	6-47
INSPECTION	6-49
SIDE CLEARANCE ADJUSTMENT	6-51
INSTALLATION	6-53
DRIVE CHAIN AND SPROCKET	6-55
REMOVAL	6-55
INSPECTION	6-57
INSTALLATION	6-59

**CHAPTER 7.
ELECTRICAL**

YFS200U CIRCUIT DIAGRAM 7-1

ELECTRICAL COMPONENTS 7-3

IGNITION SYSTEM 7-5
 CIRCUIT DIAGRAM 7-5
 TROUBLESHOOTING 7-7

LIGHTING SYSTEM 7-15
 CIRCUIT DIAGRAM 7-15
 TROUBLESHOOTING 7-17

SIGNAL SYSTEM 7-25
 CIRCUIT DIAGRAM 7-25
 TROUBLESHOOTING 7-27







**CHAPTER 8.
TROUBLESHOOTING**

STARTING FAILURE/HARD STARTING 8-1
 FUEL SYSTEM..... 8-1
 ELECTRICAL SYSTEM..... 8-2
 COMPRESSION SYSTEM..... 8-3

POOR IDLE SPEED PERFORMANCE 8-3
 POOR IDLE SPEED PERFORMANCE..... 8-3
 POOR MEDIUM AND HIGH SPEED PERFORMANCE..... 8-4
 ELECTRICAL SYSTEM..... 8-4
 COMPRESSION SYSTEM..... 8-5

FAULTY GEAR SHIFTING 8-6
 HARD SHIFTING..... 8-6
 CHANGE PEDAL DOES NOT MOVE 8-6
 JUMP-OUT GEAR 8-6

CLUTCH SLIPPING/Dragging 8-7
 CLUTCH SLIPPING 8-7
 CLUTCH DRAGGING 8-7

	GEN INFO	1
	SPEC	2
	INSP ADJ	3
	ENG	4
	CARB	5
	CHAS	6
	ELEC	7
?	TRBL SHTG	8

IMPROPER KICKING	8-8
SLIPPING	8-8
HARD KICKING	8-8
KICK CRANK NOT RETURNING	8-8
FAULTY BRAKE	8-9
POOR BRAKING EFFECT (FRONT)	8-9
POOR BRAKING EFFECT (REAR)	8-9
SHOCK ABSORBER MALFUNCTION	8-9
MALFUNCTION	8-9
INSTABLE HANDLING	8-10
INSTABLE HANDLING	8-10
FAULTY LIGHTING SYSTEM	8-11
HEADLIGHT DARK	8-11
BULB BURNT OUT	8-11
OVERHEATING	8-11
OVERHEATING	8-11

GENERAL INFORMATION

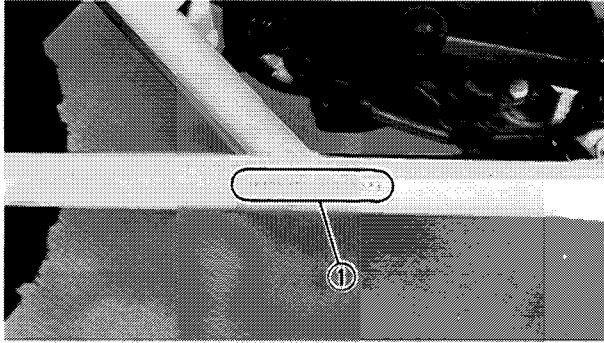

MACHINE IDENTIFICATION

VEHICLE IDENTIFICATION NUMBER (FOR USA AND CANADA)

The vehicle identification number ① is stamped into the left side of the frame.

NOTE: _____

The vehicle identification number is used to identify your machine and may be used to register your machine with the licensing authority in your state.

Starting Serial Number:
JY42XJW0 * JC000101

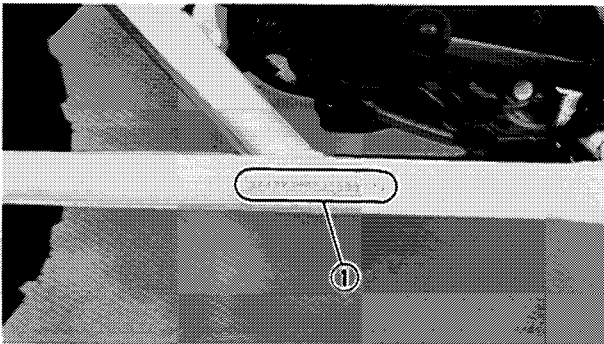

FRAME SERIAL NUMBER (EXCEPT FOR USA AND CANADA)

The frame serial number ① is stamped into the left side of frame.

NOTE: _____

The first three digits of these numbers are for model identifications; the remaining digits are the unit production number.

Starting Serial Number:
2XJ-000101

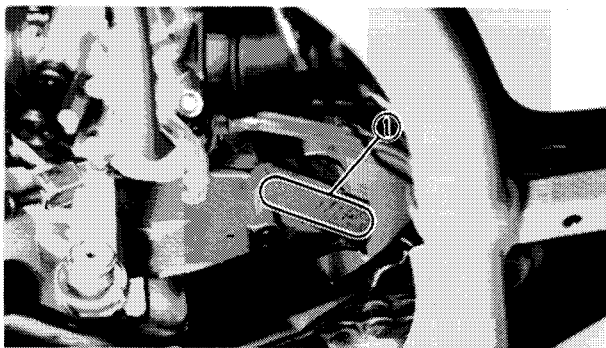

ENGINE SERIAL NUMBER

The engine serial number ① is stamped into the right side of the engine.

NOTE: _____

The first three digits of these numbers are for model identifications; the remaining digits are the unit production number.

Starting Serial Number:
2XJ-000101

NOTE: _____

Designs and specifications are subject to change without notice.

IMPORTANT INFORMATION**PREPARATION FOR REMOVAL**

1. Remove all dirt, mud, dust and foreign material before removal and disassembly.
2. Use proper tools and cleaning equipment. Refer to "CHAPTER 1. GENERAL INFORMATION-SPECIAL TOOLS" section.
3. When disassembling the machine, keep mated parts together. This includes gears, cylinder, piston and other parts that have been "mated" through normal wear. Mated parts must be reused as an assembly or replaced.
4. During the machine disassembly, clean all parts and place them in trays in the order of disassembly. This will speed up assembly time and help assure that all parts are correctly reinstalled.
5. Keep away from fire.

ALL REPLACEMENT PARTS

1. We recommended to use Yamaha genuine parts for all replacements. Use oil and/or grease recommended by Yamaha for assembly and adjustment. Other brands may be similar in function and appearance, but inferior in quality.

GASKETS, OIL SEALS, AND O-RINGS

1. All gaskets, seals, and O-rings should be replaced when an engine is overhauled. All gasket surfaces, oil seal lips, and O-rings must be cleaned.
2. Properly oil all mating parts and bearings during reassembly. Apply grease to the oil seal lips.

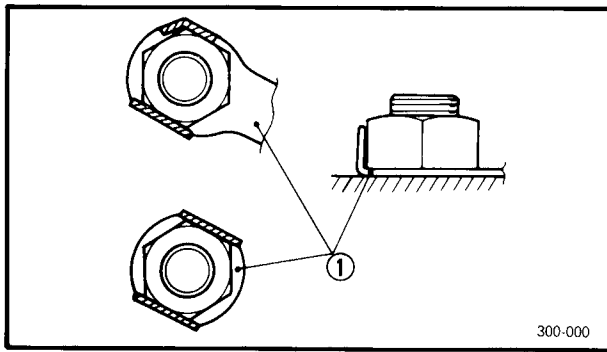

LOCK WASHERS/PLATES AND COTTER PINS

1. All lock washers/plates ① and cotter pins must be replaced when they are removed. Lock tab(s) should be bent along the bolt or nut flat(s) after the bolt or nut has been properly tightened.

1

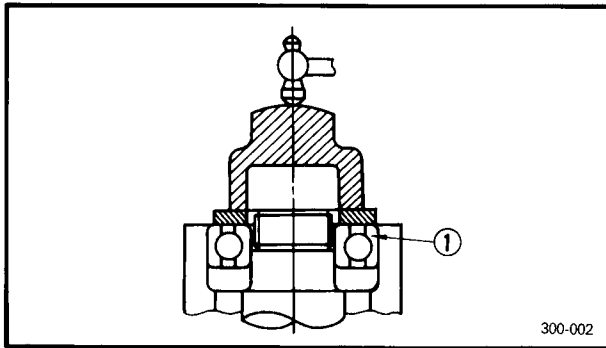

BEARINGS AND OIL SEALS

1. Install the bearing(s) ① and oil seal(s) ② with their manufacturer's marks or numbers facing outward. (In other words, the stamped letters must be on the side exposed to view.) When installing oil seal(s), apply a light coating of light-weight lithium base grease to the seal lip(s). Oil the bearings liberally when installing.

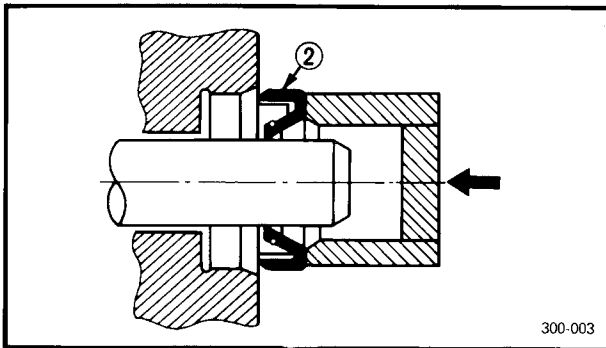

⚠ WARNING:

Do not use compressed air to spin the bearings dry. This causes damage to the bearing surfaces and may cause the bearing to explode.

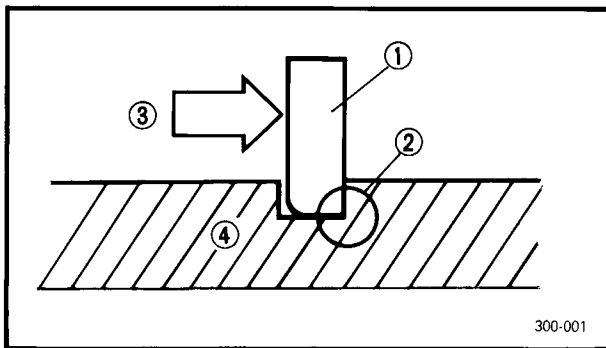

CIRCLIPS

1. All circlips should be inspected carefully before reassembly. Always replace piston pin clips after one use. Replace distorted circlips. When installing a circlip ①, make sure that the sharp edged corner ② is positioned opposite to the thrust ③ it receives. See the sectional view.

④ Shaft

SPECIAL TOOLS

The proper special tools are necessary for complete and accurate tune-up and assembly. Using the correct special tool will help prevent damage caused by the use of improper tools or improvised techniques.

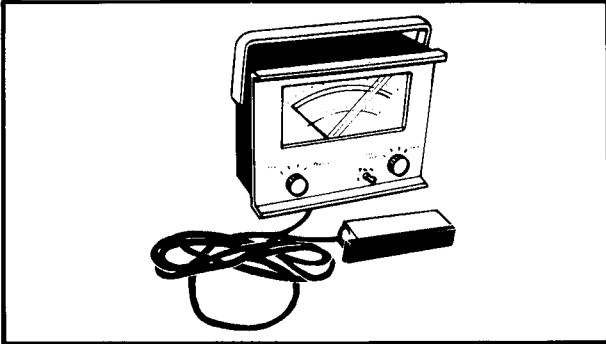
1**FOR TUNE UP**

1. Inductive Tachometer
P/N YU-08036
P/N 90890-03113

This tool is needed for detecting engine rpm.

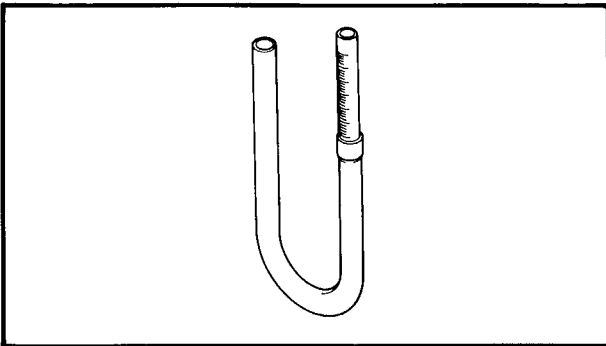

2. Fuel Level Gauge
P/N YM-01312-A
P/N 90890-01312

This gauge is used to measure the fuel level in the float chamber.

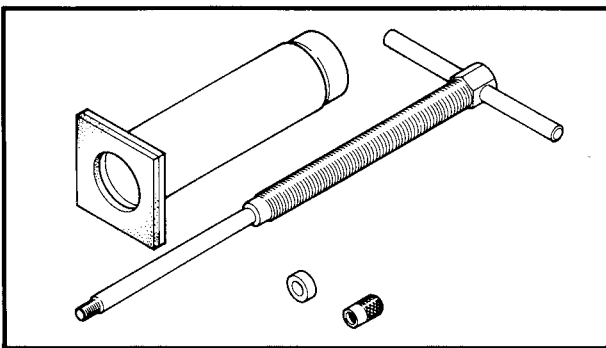
**FOR ENGINE SERVICE**

1. Piston Pin Puller
P/N YU-01304
P/N 90890-01304

This tool is used to remove the piston pin.

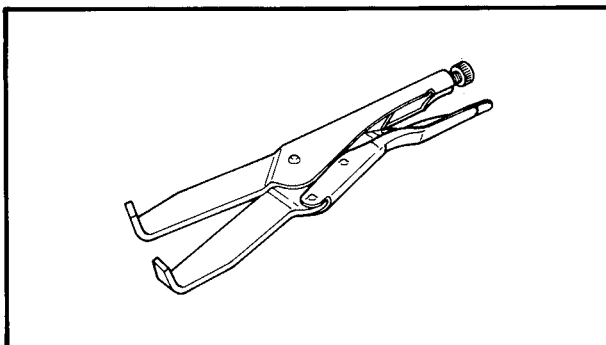

2. Universal Clutch Holder
P/N YM-91042
P/N 90890-04086

This tool is used to hold the clutch when removing or installing the clutch boss securing nut.

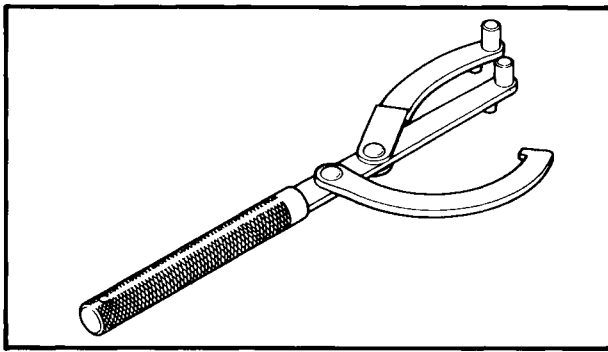

3. Rotor Holder
P/N YU-01235
P/N 90890-01235

This tool is used to hold the CDI rotor when removing or installing the primary drive gear, balancer gear and CDI rotor securing nut.

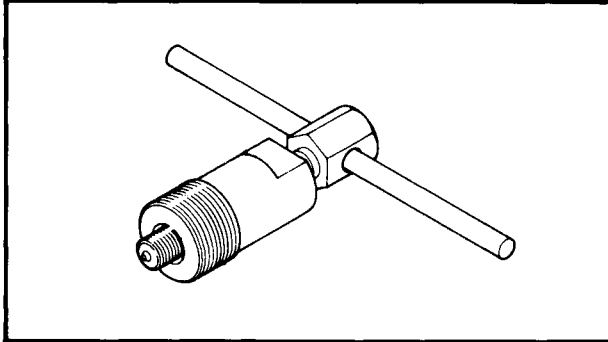

4. Rotor Puller
P/N YM-01189
P/N 90890-01189

This tool is used to remove the CDI rotor.

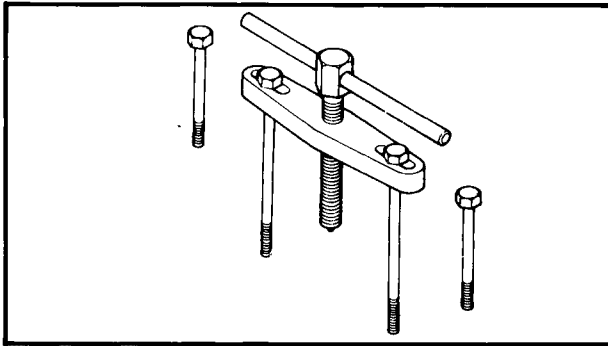

5. Crankcase Separating Tool
P/N YU-01135
P/N 90890-01135

This tool is used to separate the crankcase and remove the crankshaft.

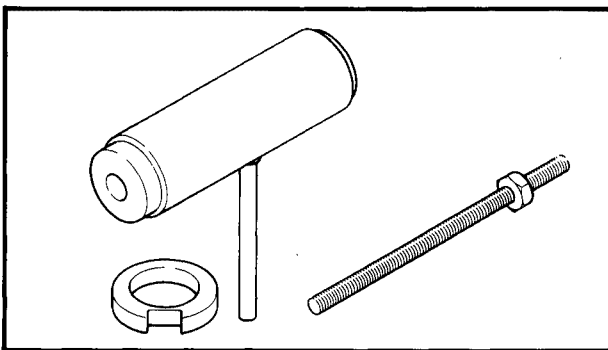

6. Crankshaft Installing Tool
P/N YU-90050
P/N 90890-01274
P/N 90890-01275

These tools are used to install the crankshaft.

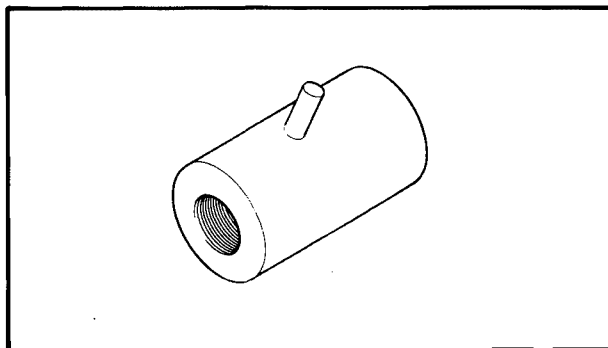

7. Adapter #12
P/N YM-90063
P/N 90890-01278

This tool is used to install the crankshaft.

1



1

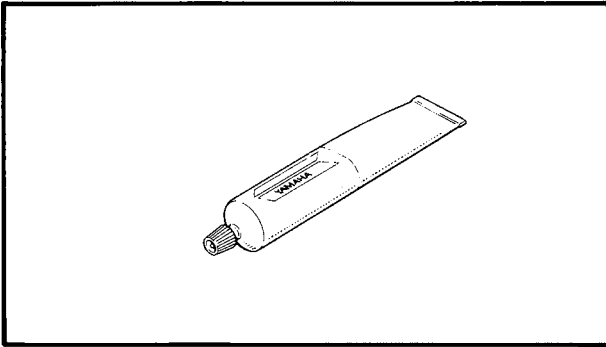

8. Sealant (Quick Gasket®)
P/N ACC-11001-05-01
P/N 90890-05143

This sealant (Bond) is used for crankcase mating surfaces, etc.

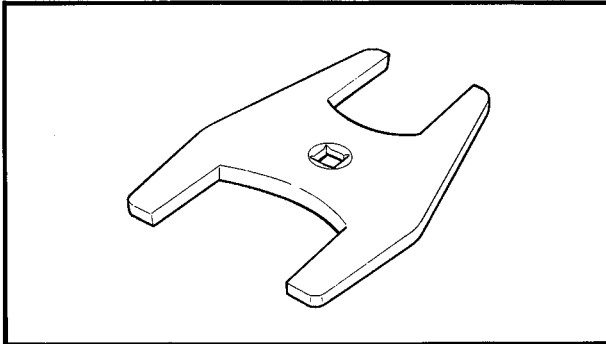

FOR CHASSIS SERVICE

1. Rear Axle Nut Wrench
P/N YM-37132
P/N 90890-01419

This tool is used to loosen and tighten the rear axle nut.

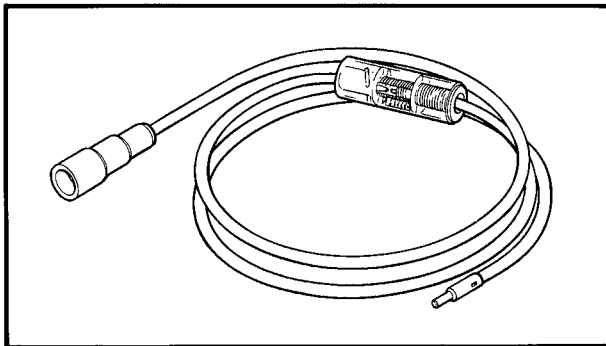

FOR ELECTRICAL COMPONENTS

1. Dynamic Coil Tester
P/N YU-34487
P/N 90890-03144

This instrument is necessary for checking the ignition system components.

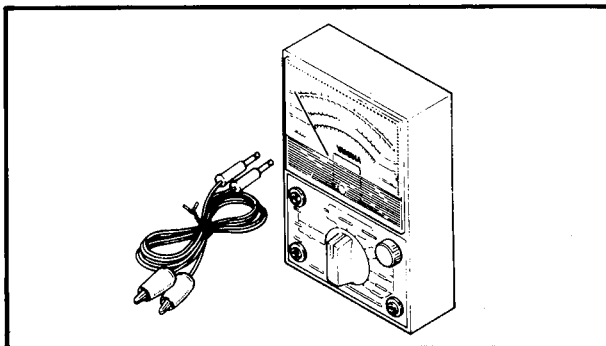

2. Pocket Tester
P/N YU-03112
P/N 90890-03112

This instrument is invaluable for checking the electrical system.



SPECIFICATIONS

GENERAL SPECIFICATIONS

Model	YFS200U
Model Code Number	2XJ
Engine Starting Number	2XJ-000101
Frame Starting Number (Except for USA and Canada)	2XJ-000101
Vehicle Identification Number (For USA and Canada)	JY42XJW0 * JC000101
Dimensions:	
Overall Length	1,695 mm (66.7 in)
Overall Width	1,035 mm (40.7 in)
Overall Height	1,040 mm (40.9 in)
Seat Height	740 mm (29.1 in)
Wheelbase	1,100 mm (43.3 in)
Minimum Ground Clearance	120 mm (4.72 in)
Basic Weight:	
With Oil and Full Fuel Tank	150 kg (331 lb)
Minimum Turning Radius:	3,000 mm (118 in)
Engine:	
Engine Type	Air Cooled 2-Stroke
Induction System	Reed Valve
Cylinder Arrangement	Forward Inclined Single Cylinder
Displacement	195 cm ³
Bore x Stroke	66 x 57 mm (2.598 x 2.244 in)
Compression Ratio	6.6 : 1
Starting System	Kick starter
Lubrication System:	
Engine Oil	Separate Lubrication (Yamaha Autolube) Yamalube 2 or Air Cooled 2-stroke Engine Oil
Transmission Oil	Yamalube 4 (10W30) and SAE 10W30 Type SE Motor Oil
Oil Capacity:	
Oil Tank (Engine Oil)	1.3 L (1.1 Imp qt, 1.4 US qt)
Transmission Oil	
Periodic Oil Change	0.65 L (0.57 Imp qt, 0.69 US qt)
Total Amount	0.70 L (0.62 Imp qt, 0.74 US qt)
Air Filter:	Wet Type Element
Fuel:	
Type	Premium Gasoline
Fuel Tank Capacity	9 L (1.98 Imp gal, 2.38 US gal)
Fuel Reserve Amount	2 L (0.44 Imp gal, 0.53 US gal)
Carburetor:	
Type/Quantity	VM26SS/1 pc.
Manufacturer	MIKUNI

2



2

Model	YFS200U	
Spark Plug: Type/Manufacture	For USA and Oceania B8ES/NGK, W24ES/NIPPON DENSO For Canada and S. Africa BP8ES/NGK	
Spark Plug Gap	0.7 ~ 0.8 mm (0.028 ~ 0.032 in)	
Clutch Type:	Wet, Multiple-disc	
Transmission: Primary Reduction System Primary Reduction Ratio Secondary Reduction System Secondary Reduction Ratio Transmission Type Operation Gear Ratio: 1st 2nd 3rd 4th 5th 6th	Helical Gear 71/22 (3.227) Chain Drive 40/13 (3.077) Constant Mesh 6-Speed Left Foot Operation 34/11 (3.091) 31/14 (2.214) 25/15 (1.667) 20/16 (1.250) 19/18 (1.056) 19/21 (0.905)	
Chassis: Frame Type Caster Angle Trail Tread (Standard): Rear Front Toe-in	Steel Tube Frame 9° 40 mm (1.57 in) 780 mm (30.7 in) 820 mm (32.3 in) 0 ~ 10 mm (0 ~ 0.39 in)	
Tire: Type Size: Front Rear	Tubeless AT21 x 7 – 10 AT21 x 10 – 8	
Tire Pressure (Cold Tire):	Front	Rear
Recommended	30 kPa (0.30 kg/cm ³ , 4.3 psi)	25 kPa (0.25 kg/cm ³ , 3.6 psi)
Minimum	27 kPa (0.27 kg/cm ³ , 3.8 psi)	22 kPa (0.22 kg/cm ³ , 3.1 psi)
Maximum	33 kPa (0.33 kg/cm ³ , 4.7 psi)	28 kPa (0.28 kg/cm ³ , 4.0 psi)
Brake: Front Brake Type Front Brake Operation Rear Brake Type Rear Brake Operation	Drum Brake Right Hand Operation Single Disc Brake Right Foot Operation	

GENERAL SPECIFICATIONS



Model	YFS200U
Suspension: Front Rear	Double Wishbone Swingarm
Shock Absorber: Front Rear	Coil Spring/Oil Damper Coil Spring/Gas-Oil Damper
Wheel Travel: Front Rear	180 mm (7.09 in) 180 mm (7.09 in)
Electrical: Ignition System Generator System Headlight Type Bulb Wattage x Quantity: Headlight Tail Light Indicator Light "OIL LEVEL"	C.D.I. Flywheel Magneto Bulb type 12V, 45W/45W x 1 12V, 3.8W x 1 12V, 3.4W x 1

2

MAINTENANCE SPECIFICATIONS
ENGINE

2

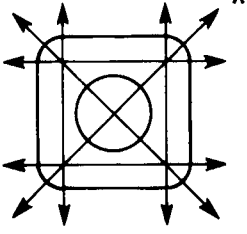
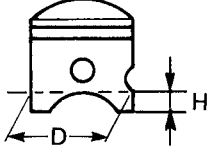
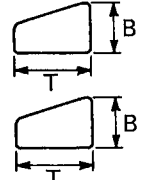
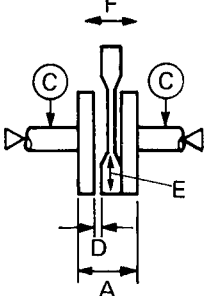
Model	YFS200U
<p>Cylinder Head: < Warp Limit ></p> 	<p>< 0.03 mm (0.0012 in) > * Lines indicate straightedge measurement.</p>
<p>Cylinder: Bore Size < Taper Limit > < Out of Round Limit ></p>	<p>66.00 ~ 66.02 mm (2.598 ~ 2.599 in) < 0.08 mm (0.003 in) > < 0.05 mm (0.002 in) ></p>
<p>Piston: Piston Size "D" Measuring Point "H" Piston Off-Set Piston-to-Cylinder Clearance Oversize 1st 2nd</p> 	<p>65.965 ~ 66.000 mm (2.597 ~ 2.598 in) 10 mm (0.39 in) 0 mm (0 in) 0.035 ~ 0.040 mm (0.0014 ~ 0.0016 in) 66.25 mm (2.608 in) 66.50 mm (2.618 in)</p>
<p>Piston Ring: Sectional Sketch</p>  <p>End Gap (Installed)</p> <p>Side Clearance</p>	<p>Top Ring Keystone B = 1.2 mm (0.047 in) T = 2.8 mm (0.110 in)</p> <p>2nd Ring Keystone B = 1.2 mm (0.047 in) T = 2.8 mm (0.110 in)</p> <p>Top Ring 0.20 ~ 0.35 mm (0.008 ~ 0.014 in)</p> <p>2nd Ring 0.20 ~ 0.35 mm (0.008 ~ 0.014 in)</p> <p>Top Ring 0.03 ~ 0.05 mm (0.0012 ~ 0.0020 in)</p> <p>2nd Ring 0.03 ~ 0.05 mm (0.0012 ~ 0.0020 in)</p>
<p>Crankshaft:</p>  <p>Crank Width "A" < Runout Limit "C" > Big End Side Clearance "D" Big End Radial Clearance "E" Small End Free Play "F"</p>	<p>57.90 ~ 57.90 mm (2.280 ~ 2.281 in) < 0.03 mm (0.0012 in) > 0.4 ~ 0.7 mm (0.016 ~ 0.028 in) 0.021 ~ 0.035 mm (0.0008 ~ 0.0014 in) 0.8 ~ 1.0 mm (0.031 ~ 0.039 in)</p>



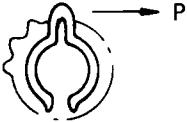

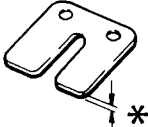

Model	YFS200U
Ballancer: Ballancer Drive Method	Gear
Clutch: Friction Plate Thickness/Quantity < Wear Limit > Clutch Plate Thickness/Quantity < Warp Limit > Clutch Spring Free Length/Quantity Clutch Spring Minimum Length Clutch Housing Radial Clearance Clutch Release Method < Push Rod Bending Limit >	2.92 ~ 3.08 mm (0.115 ~ 0.121 in)/7 pcs. < 2.8 mm (0.110 in) > 1.05 ~ 1.35 mm (0.041 ~ 0.053 in)/5 pcs. < 0.05 mm (0.002 in) > 32.5 mm (1.28 in)/5 pcs. 30.0 mm (1.18 in) 0.015 ~ 0.049 mm (0.0006 ~ 0.0019 in) Inner push, Cam push < 0.15 mm (0.006 in) >
Transmission: < Main Axle Runout Limit > < Drive Axle Runout Limit >	< 0.08 mm (0.003 in) > < 0.08 mm (0.003 in) >
Shifter: Type	Cam Drum and Guide Bar
Kick Starter: Kick Starter Type Kick Clip Friction Force	Kick and Mesh Type P = 0.8 ~ 1.2 kg (1.8 ~ 2.6 lb)
	
Air Filter Oil Grade:	Foam-Air-Filter Oil or SAE 10W30 SE
Carburetor: Type/Manufacturer/Quantity I.D. Mark Main Jet (M.J.) Main Air Jet (M.A.J.) Jet Needle-clip Position (J.N.) Needle Jet (N.J.) Cutaway (C.A.) Pilot Outlet (P.O.) Pilot Jet (P.J.) Bypass 1 (B.P. 1) Pilot Air Screw (P.A.S.) Valve Seat Size (V.S.) Starter Jet (G.S.) Float Height (F.H.) Fuel Level (F.L.) Engine Idling Speed	VM26SS/MIKUNI/1 2XJ 00 # 220 φ 0.7 5J22-2 P-6 (# 345) 2.0 0.6 # 32.5 0.8 x 3.75 1 and 1/2 turns out φ 2.8 # 45 20.0 ~ 21.5 mm (0.79 ~ 0.85 in) 0.5 ~ 1.5 mm (0.02 ~ 0.06 in) 1,450 ~ 1,550 r/min



Model	YFS200U
Reed Valve: Thickness * Valve Stopper Height < Valve Bending Limit >	 0.35 ~ 0.49 mm (0.014 ~ 0.019 in) 8.3 ~ 8.7 mm (0.33 ~ 0.34 in) < 0.5 mm (0.02 in) >
Lubrication System: Autolube Pump Stroke Output at 200 Strokes	1.95 ~ 2.05 mm (0.077 ~ 0.081 in) 3.47 ~ 4.23 cm ³ (0.122 ~ 0.149 Imp oz, 0.117 ~ 0.143 US oz)

2

Tightening Torque:					
Part to be tightened	Thread size	Tightening Torque			Remarks
		Nm	m · kg	ft · lb	
Cylinder Head	M8 x 1.25	27	2.7	20	
Cylinder	M8 x 1.25	25	2.5	18	
Spark Plug	—	25	2.5	18	
Reed Valve Assembly	M6 x 1.0	8	0.8	5.8	
Reed Valve	M3 x 0.5	1	0.1	0.7	
Primary Drive Gear	M12 x 1.25	80	8.0	58	
Clutch Boss	M12 x 1.25	80	8.0	58	
Clutch Spring	M5 x 0.8	6	0.6	4.3	
Clutch Adjuster Locknut	M6 x 1.0	7	0.7	5.1	
Drive Sprocket Stopper	M6 x 1.0	10	1.0	7.2	
Kick Crank	M12 x 1.25	65	6.5	47	
Shift Pedal	M6 x 1.0	14	1.4	10	
Flywheel Magneto	M12 x 1.25	73	7.3	53	
Stator Assembly	M6 x 1.0	8	0.8	5.8	
Exhaust Pipe	M8 x 1.25	21	2.1	15	
Drain Plug (Transmission)	M12 x 1.25	20	2.0	14	
Oil Level Check Bolt	M10 x 1.25	18	1.8	13	
Crankcase Cover (Right)	M6 x 1.0	10	1.0	7.2	
(Left)	M6 x 1.0	10	1.0	7.2	
Autolube Pump Cover	M6 x 1.0	7	0.7	5.1	
Bearing Stopper (Crankshaft)	M8 x 1.25	16	1.6	12	
(Main axle)	M6 x 1.0	10	1.0	7.2	
Crankcase	M6 x 1.0	8	0.8	5.8	
Shift Cam Stopper Lever	M6 x 1.0	14	1.4	10	
Carburetor Switch	—	10	1.0	7.2	
Autolube Pump	M5 x 0.8	5	0.5	3.6	

2



CHASSIS

Model	YFS200U	
Steering System:		
Lock to Lock Angle	Left Right	40° 40°
Front Suspension:		
Shock Absorber Travel		90 mm (3.54 in)
Suspension Spring Free Length		226.6 mm (8.93 in)
Spring Rate	K1 K2	30.0 N/mm (3.0 kg/mm, 168 lb/in) 35.0 N/mm (3.5 kg/mm, 196 lb/in)
Stroke	K1 K2	0 ~ 46.7 mm (0 ~ 1.84 in) 46.7 ~ 112.2 mm (1.84 ~ 4.42 in)
Optional Spring		No.
Rear Suspension:		
Shock Absorber Travel		80 mm (3.15 in)
Spring Free Length		245 mm (9.65 in)
Spring Rate	K1 K2	45.0 N/mm (4.5 kg/mm, 252 lb/in) 80.0 N/mm (8.0 kg/mm, 448 lb/in)
Stroke	K1 K2	0 ~ 55.0 mm (0 ~ 2.17 in) 55.0 ~ 105.0 mm (2.17 ~ 4.13 in)
Optional Spring		No.
Swingarm:		
Free Play Limit		< 1.0 mm (0.04 in) > at swignarm end Move swingarm and side to side.
Side Clearance		0.4 ~ 0.7 mm (0.016 ~ 0.027 in) at swingarm pivot
Front Wheel:		
Type		Panel Wheel
Rim Size		10 x 5.5 AT
Rim Material		Steel
Rim Runout Limit	< Vertical > < Lateral >	< 2.0 mm (0.08 in) > < 2.0 mm (0.08 in) >
Rear Wheel:		
Type		Panel Wheel
Rim Size		8 x 8.0 AT
Rim Material		Steel
Rim Runout Limit	< Vertical > < Lateral >	< 2.0 mm (0.08 in) > < 2.0 mm (0.08 in) >
Drive Chain:		
Type/Manufacturer		520V6/DAIDO
No. of Links		92
Chain Free Play		30 ~ 40 mm (1.18 ~ 1.57 in)
Front Drum Brake:		
Type		Leading, Trailing
Brake Drum Inside Diameter		110 mm (4.33 in)
< Limit >		< 111 mm (4.37 in) >
Lining Thickness		4.0 mm (0.16 in)
< Limit >		< 2.0 mm (0.08 in) >
Shoe Spring Free Length		50.5 mm (1.99 in)

2



Model	YFS200U
Rear Disc Brake: Type Disc Outside Diameter x Thickness Pad Thickness – Inner < Limit > Pad Thickness – Outer < Limit >	Single 220.0 x 3.8 mm (8.66 x 0.15 in) 7.3 mm (0.29 in) < 1.0 mm (0.04 in) > 4.8 mm (0.19 in) < 1.0 mm (0.04 in) >
Brake Pedal: Brake Pedal Position	10 mm (0.39 in)
Clutch Lever: Clutch Lever Free Play	5 ~ 8 mm (0.20 ~ 0.31 in) at lever pivot



2

Tightening Torque:					
Parts to be tightened	Thread Size	Tightening Torque			Remarks
		Nm	m · kg	ft · lb	
Engine Mount:					
Engine (Front) and Frame	M10 x 1.25	45	4.5	33	
Engine (Rear) and Frame	M8 x 1.25	33	3.3	24	
Pivot Shaft and Frame	M14 x 1.5	85	8.5	61	
Swingarm and Under Guard	M8 x 1.25	23	2.3	17	
Rear Shock Absorber (Upper) and Frame	M10 x 1.25	25	2.5	18	
Front Arm (Lower and Upper) and Frame	M10 x 1.25	30	3.0	22	
Front Shock Absorber (Upper and Lower)	M10 x 1.25	45	4.5	33	
Steering Knuckle and Ball Joint	M10 x 1.25	48	4.8	35	
Steering Knuckle and Knuckle Arm	M10 x 1.25	38	3.8	27	
Knuckle Arm and Tie-Rod End	M10 x 1.25	25	2.5	18	
Tie-Rod (Locknut)	M10 x 1.25	30	3.0	22	
Tie-Rod End and Steering Column	M10 x 1.25	25	2.5	18	
Steering Column and Frame	M10 x 1.25	30	3.0	22	
Steering Column Holder and Frame	M8 x 1.25	23	2.3	17	Use lock washer.
Steering Column and Handlebar Holder	M8 x 1.25	20	2.0	14	
Fuel Cock	M6 x 1.0	5	0.5	3.6	
Front Wheel Nut	M10 x 1.25	45	4.5	33	
Front Hub Nut	M14 x 1.5	70	7.0	51	
Front Brake Camshaft Lever	M6 x 1.0	9	0.9	6.5	
Rear Axle Ring Nut	M33 x 1.5				SEE NOTE.
Rear Wheel Nut	M10 x 1.25	45	4.5	33	
Rear Wheel Hub Nut	M14 x 1.5	120	12	87	
Rear Axle Hub and Swingarm	M10 x 1.25	50	5.0	36	
Brake Caliper and Bracket	M8 x 1.25	23	2.3	17	
Rear Axle Hub and Brake Caliper Bracket	M8 x 1.25	28	2.8	20	
Brake Disc and Bracket	M8 x 1.25	28	2.8	20	
Chain Puller and Locknut	M8 x 1.25	16	1.6	12	
Driven Sprocket	M8 x 1.25	24	2.4	17	
Footrest	M10 x 1.25	55	5.5	40	
Front Bumper	M8 x 1.25	26	2.6	19	
Rear Bumper	M8 x 1.25	35	3.5	25	

NOTE:

Apply locking agent (LOCTITE®) to nuts threads.

1. Tighten the nut (inside) to 55 Nm (5.5 m · kg, 40 ft · lb) while holding the rear axle.
2. Hold the nut (inside) and tighten the nut (outside) to 190 Nm (19.0 m · kg, 140 ft · lb).
3. Hold the nut (outside) and tighten back the nut (inside) to 240 Nm (24.0 m · kg, 170 ft · lb).

ELECTRICAL

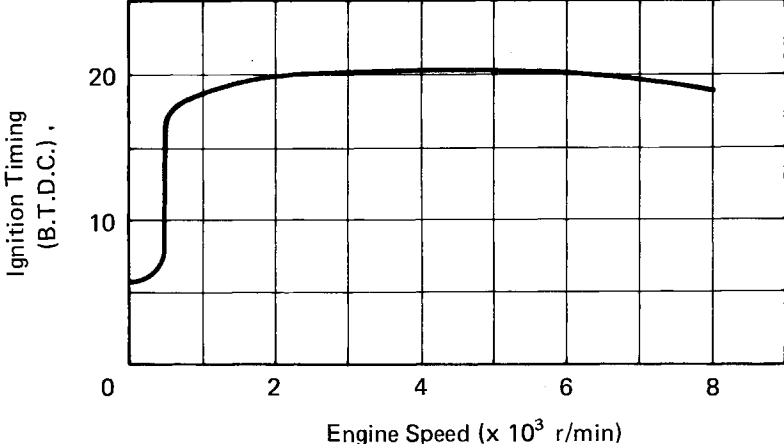
Model	YFS200U
Voltage	12V
Ignition System: Ignition Timing (B.T.D.C.) Advancer Type	16° at 3,000 r/min Electrical Type
	
C.D.I.: Magneto Model/Manufacturer Pickup Coil Resistance (Color) Charging Coil Resistance (Color) C.D.I. Unit Model/Manufacturer	F2XJ/YAMAHA 16 ~ 24 Ω at 20°C (68°F) (White/Red – Black) 192 ~ 288Ω at 20°C (68°F) (Black/Red – Black) 2XJ/YAMAHA
Ignition Coil: Model/Manufacturer Minimum Spark Gap Primary Coil Resistance Secondary Coil Resistance	C2T4/YAMAHA 6 mm (0.24 in) 1.44 ~ 1.76Ω at 20°C (68°F) 5.28 ~ 7.92KΩ at 20°C
Spark Plug Cap: Type Resistance	Rubber Type 5KΩ
Charging System: Type	Flywheel Magneto

2

2

Model	YFS200U																
<p>F.W. Magneto: Model/Manufacturer Charging Coil Resistance (Color) Lighting Voltage (Min.) (Max.)</p>	<p>F2XJ/YAMAHA 0.16 ~ 0.24Ω at 20°C (68° F) (Yellow/Red – Black) 12.5V at 3,000 r/min 15V at 8,000 r/min</p> <div data-bbox="503 409 1112 997" data-label="Figure"> <table border="1"> <caption>Lighting Voltage vs Engine Speed</caption> <thead> <tr> <th>Engine Speed (x 10³ r/min)</th> <th>Lighting Voltage (V)</th> </tr> </thead> <tbody> <tr><td>1</td><td>5.0</td></tr> <tr><td>2</td><td>11.5</td></tr> <tr><td>3</td><td>12.5</td></tr> <tr><td>4</td><td>13.0</td></tr> <tr><td>6</td><td>14.0</td></tr> <tr><td>8</td><td>14.5</td></tr> <tr><td>10</td><td>15.0</td></tr> </tbody> </table> </div>	Engine Speed (x 10 ³ r/min)	Lighting Voltage (V)	1	5.0	2	11.5	3	12.5	4	13.0	6	14.0	8	14.5	10	15.0
Engine Speed (x 10 ³ r/min)	Lighting Voltage (V)																
1	5.0																
2	11.5																
3	12.5																
4	13.0																
6	14.0																
8	14.5																
10	15.0																
<p>Voltage Regulator: Type Model/Manufacturer No Load Regulated Voltage</p>	<p>Semi Conductor - Short Circuit Type SH588/SHINDENGEN 13.5 ~ 14.1 V</p>																
<p>Oil Level Switch: Model/Manufacturer</p>	<p>2XJ/TAIHEIYO ASTI</p>																

GENERAL TORQUE SPECIFICATIONS

This chart specifies torque for standard fasteners with standard I.S.O. pitch threads. Torque specifications for special components or assemblies are included in the applicable sections of this book. To avoid warpage, tighten multifastener assemblies in a crisscross fashion, in progressive stages, until full torque is reached. Unless otherwise specified, torque specifications call for clean, dry threads. Components should be at room temperature.

A (Nut)	B (Bolt)	General torque specifications		
		Nm	m·kg	ft·lb
10mm	6mm	6	0.6	4.3
12mm	8mm	15	1.5	11
14mm	10mm	30	3.0	22
17mm	12mm	55	5.5	40
19mm	14mm	85	8.5	61
22mm	16mm	130	13.0	94

2

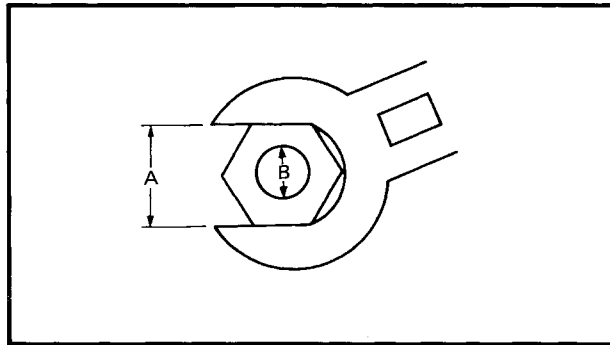











A: Distance across flats
B: Outside thread diameter

DEFINITION OF UNITS



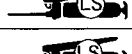











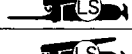

Unit	Read	Definition	Measure
mm	millimeter	10^{-3} meter	Length
cm	centimeter	10^{-2} meter	Length
kg	kilogram	10^3 gram	Weight
N	Newton	$1 \text{ kg} \times \text{m}/\text{sec}^2$	Force
Nm	Newton meter	$\text{N} \times \text{m}$	Torque
m·kg	Meter kilogram	$\text{m} \times \text{kg}$	Torque
Pa	Pascal	N/m^2	Pressure
N/mn	Newton per millimeter	N/mn	Spring rate
L	Liter	—	Volume or Capacity
cm^3	Cubic centimeter	—	Volume or Capacity
r/min	Rotation per minute	—	Engine Speed

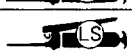
LUBRICATION POINTS AND LUBRICANT TYPE

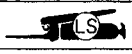
ENGINE

Lubrication Points	Lubricant Type
Bearing Retainer (All)	
Oil Seal Lips (All)/O-Rings (All)	
Crank Pins	
Piston Rings, Piston Pins and Pistons	
Kick Idle Gear	
Kick Axle	
Primary Driven Gear (Clutch Housing)	
Push Rod	
Push Lever Axle	
Guide Bar (Shift Forks)	
Crankcase Mating Surfaces	Sealant (Quick Gasket®) Yamaha Bond No. 4
Throttle Cable Ends (Carburetor Switch)	

CHASSIS



Lubrication Points	Lubricant Type
Oil Seal Lips (All)/O-Rings (All)	
Swingarm (Pivot Shaft, Bushe, Bearing)	
Steering Shaft (Upper and Lower Bushes)	
Front Wheel (Pivoting Points)	
Bushes (Front Shock Absorber)	
Pivot Shaft (Front Arm)	
Front Drum Brake Brake Cam Shaft Pivot Pin Backing Plate	  
Front Brake Cable Joint	
Front Brake Lever Pivot	
Clutch Lever Pivot	
Throttle Lever Holding Cable End	
Bushes (Rear Shock Absorber)	
Pivot Shaft (Swing Arm)	
Rear Brake Disc Bracket	

2

LUBRICATION POINTS AND LUBRICANT TYPE

SPEC



Lubricant Points	Lubricant Type
Rear Brake Calp	
Disc Pad Base Side-Surface (Outer)	Cilicon KS62M Grease
Disc Pad O-Ring	Cilicon KS62M Grease
Disc Pad Grommet	Cilicon KS62M Grease
Adjuster	
Ratchet Spring	
Rear Brake Pedal Pivot	

NOTE:

Cilicon grease KS62M is supplied in the spare brake pads kit.

2

CABLE ROUTING

- ① Clutch cable
- ② Parking brake cable
- ③ Front brake cable
- ④ Throttle switch lead
- ⑤ Throttle cable
- ⑥ Band
- ⑦ Handlebar switch lead (Left)
- ⑧ Voltage regulator lead
- ⑨ Main switch lead
- ⑩ Wire harness
- ⑪ Ground lead

- A For installation of the clutch cable through the guide, route the clutch cable on the left side of the front brake cable.
- B The parking brake cable should be routed behind the front brake cable, and on the right side of the guide.
- C The throttle cable should be routed through the guide behind the clutch cable.
- D Leads should be routed behind the cables.
- E The ground and voltage regulator leads should be routed in front of the cables.

2

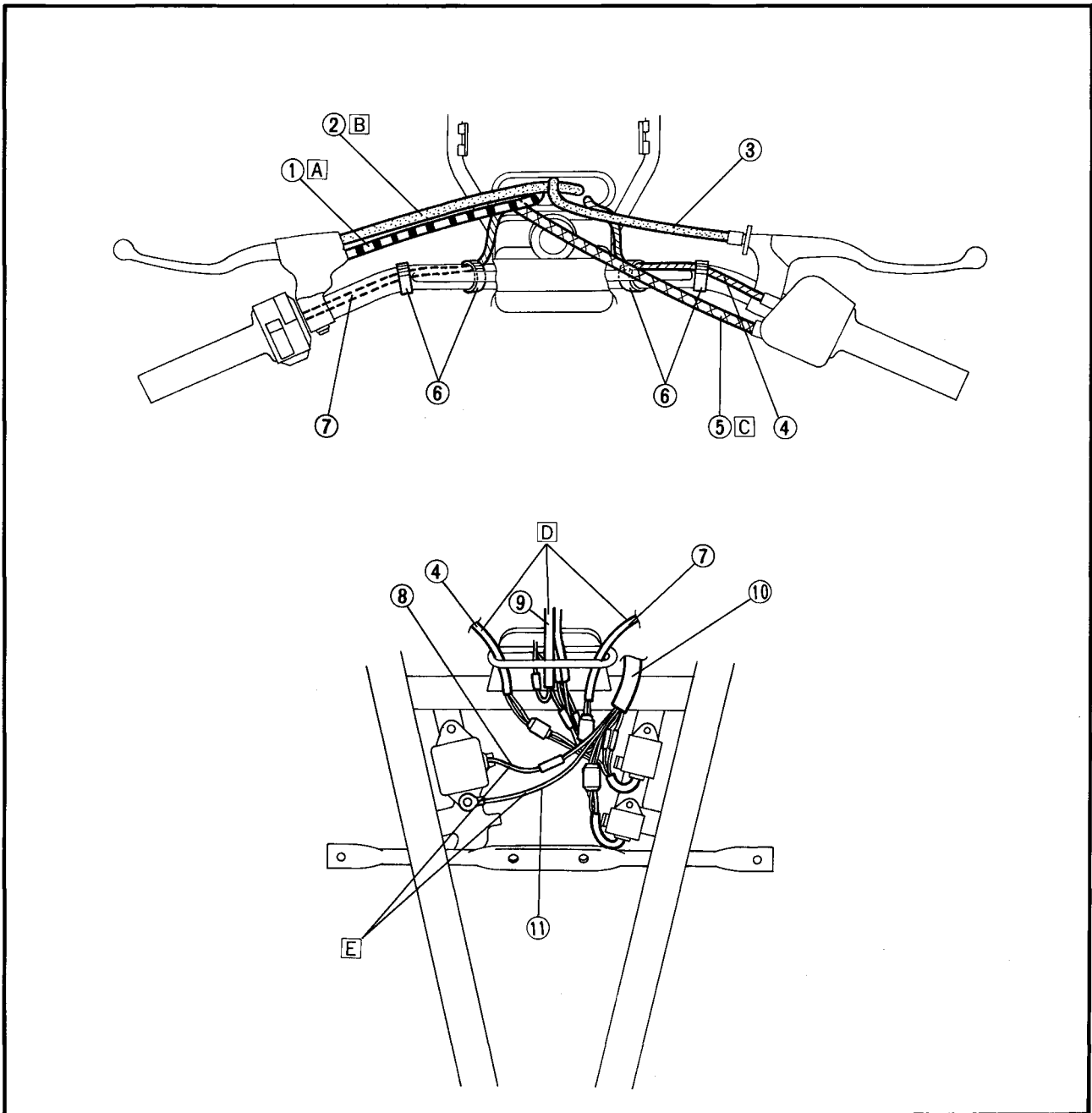

- ① Front brake cable
- ② Clutch cable
- ③ Main switch lead
- ④ Fuel breather hose
- ⑤ Band
- ⑥ Fuel hose
- ⑦ Wire holder
- ⑧ Clamp
- ⑨ Oil hose

- ⑩ Carburetor overflow hose
- ⑪ Flywheel magneto lead
- A Route the clutch cable in front of the fender stay.
- B For installing the wireharness, align the positioning tape with the wire holder.
- C The leads should be clamped on the inward half of the frame pipe.

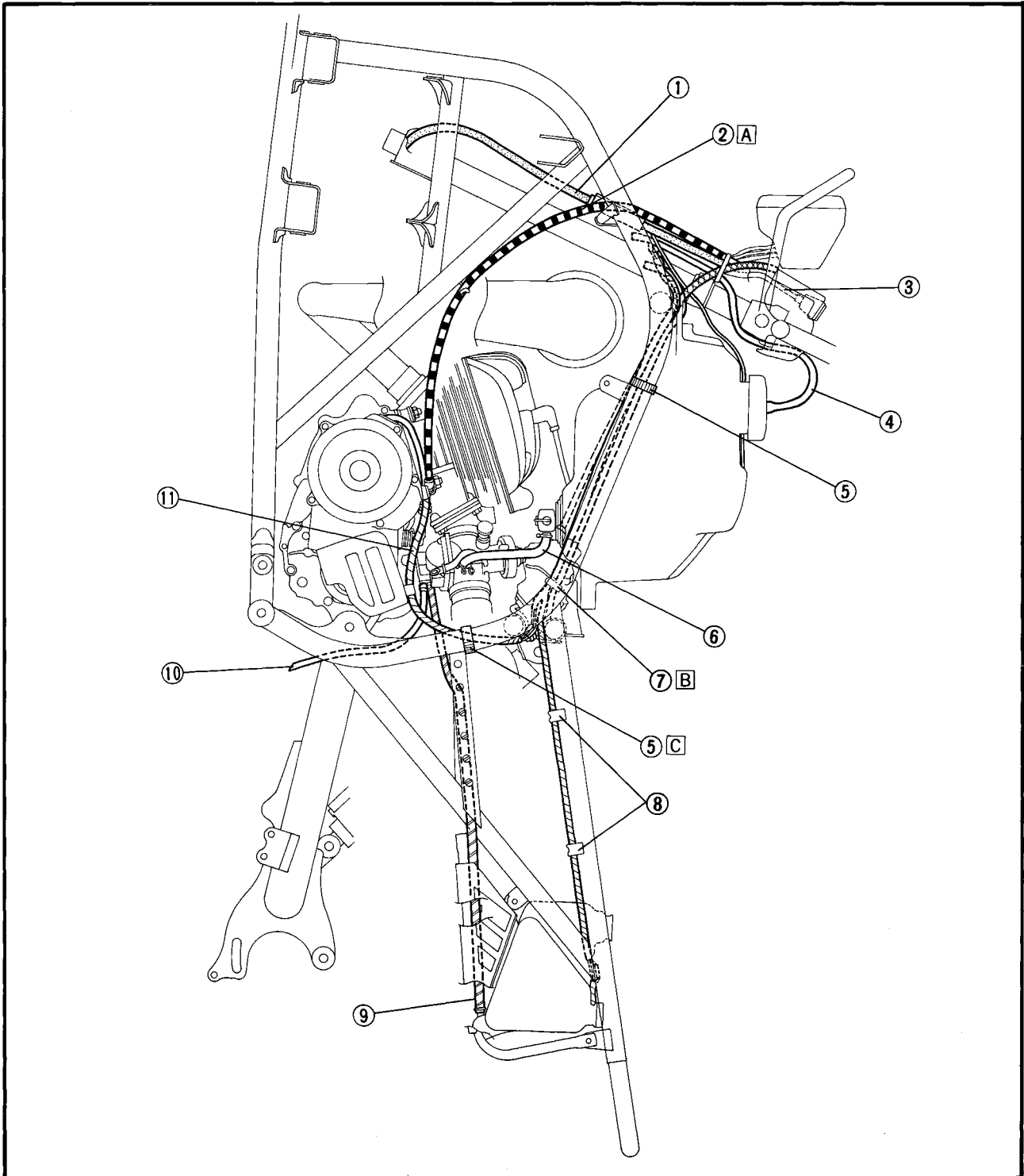

2



- ① Parking brake cable
- ② Cable guide
- ③ Rear brake cable
- ④ Oil hose
- ⑤ Crankcase ventilation hose

A Route the parking brake cable in front of the fender stay.

2

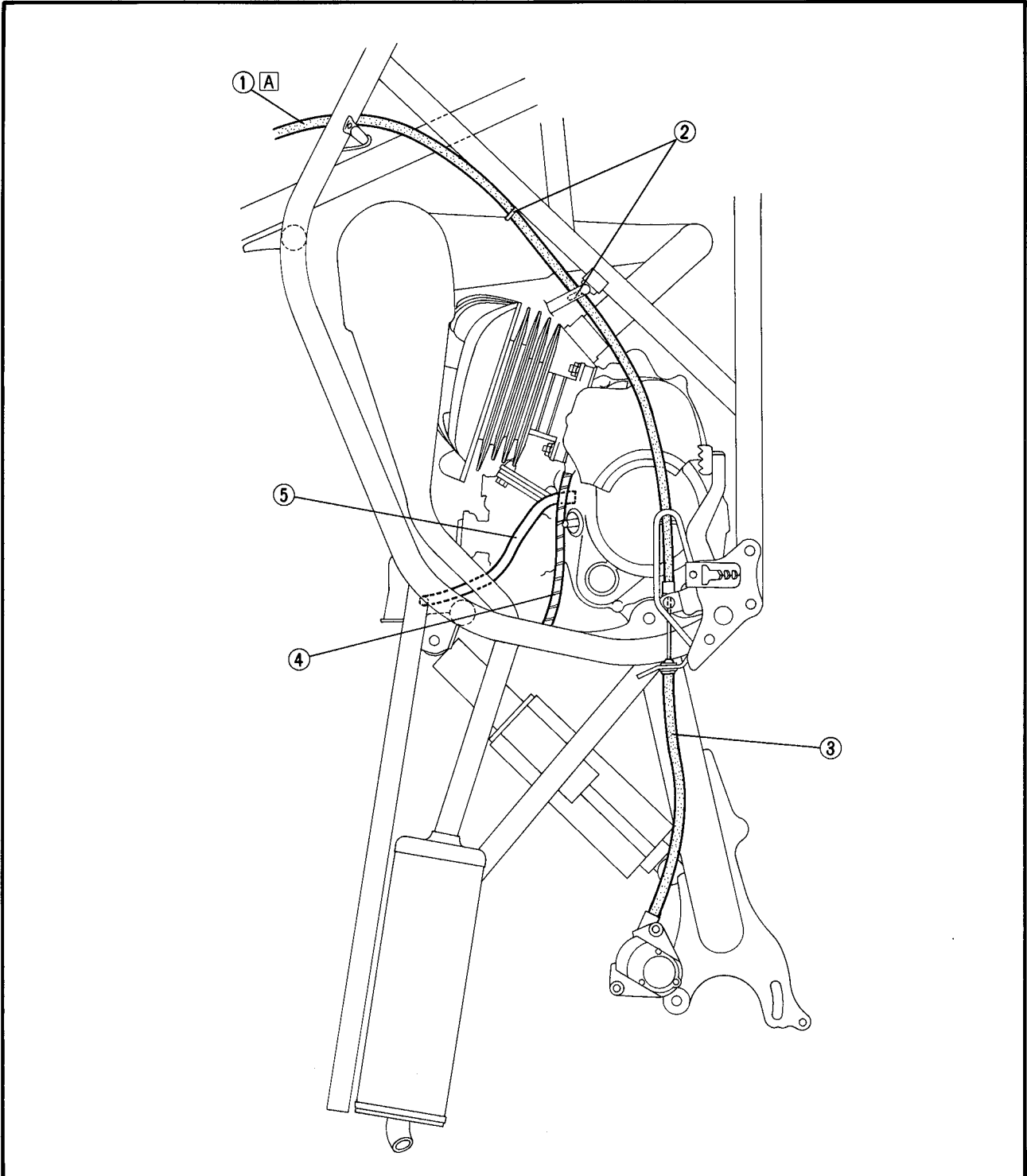



- ① Spark plug lead
- ② Crankcase ventilation hose
- ③ Band
- ④ Tail/Brake light lead
- ⑤ Oil level gauge lead
- ⑥ Oil hose
- ⑦ Wire harness
- ⑧ Carburetor switch lead
- ⑨ Throttle cable

A Clamp the ignition coil lead, ground lead and crank case ventilation hose on the frame cross pipe.

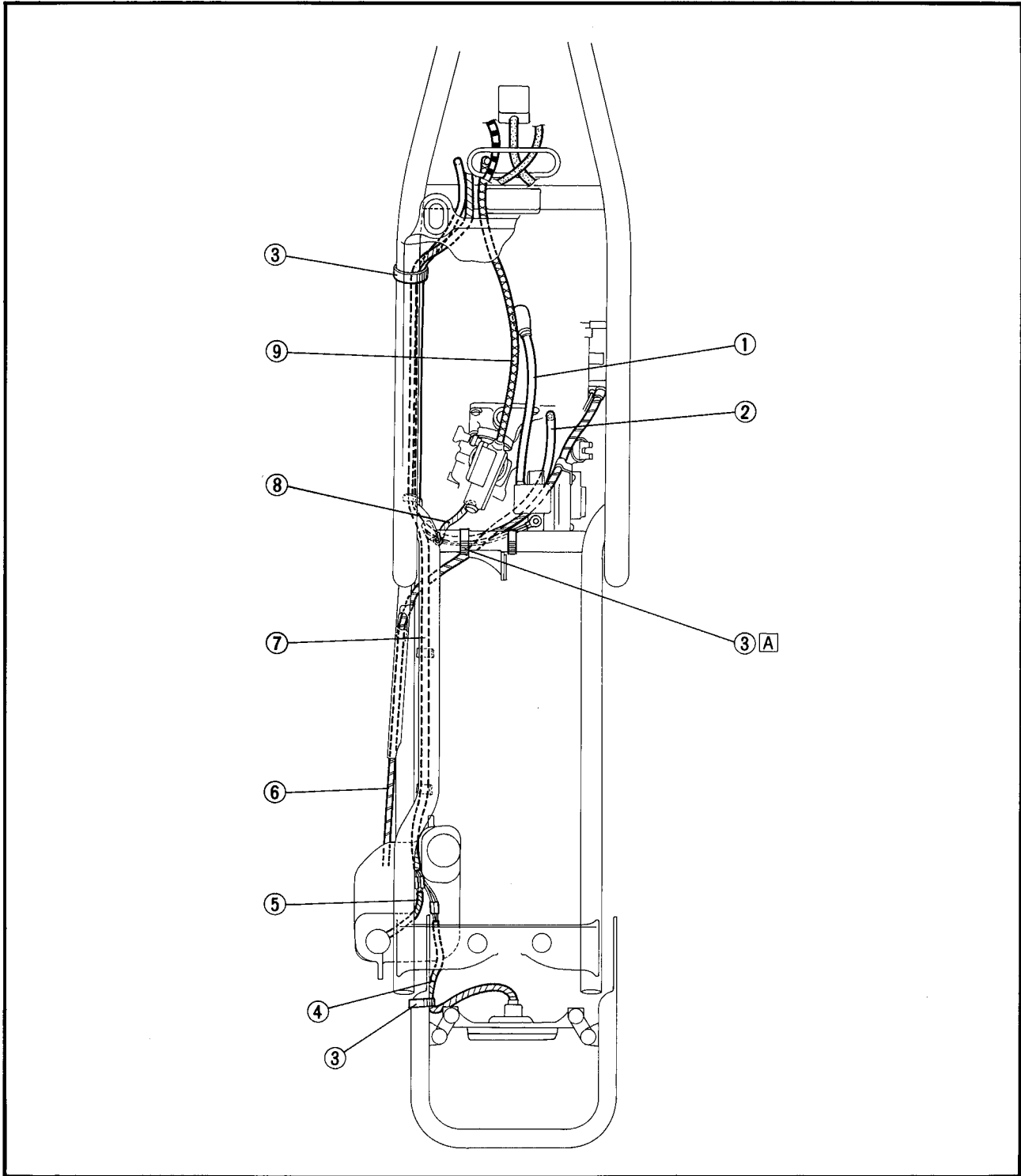

2

- ① Oil hose
- ② Oil delivery hose
- ③ Ventilation hose
- ④ CDI magneto lead
- ⑤ Clutch cable

- A Tighten the oil hose holder with the crankcase cover (Right).
- B Position the stopper of the oil hose and oil delivery hose against the autolube pump cover.
- C Route the CDI magneto lead through the clamp of the crankcase cover (Left).

2

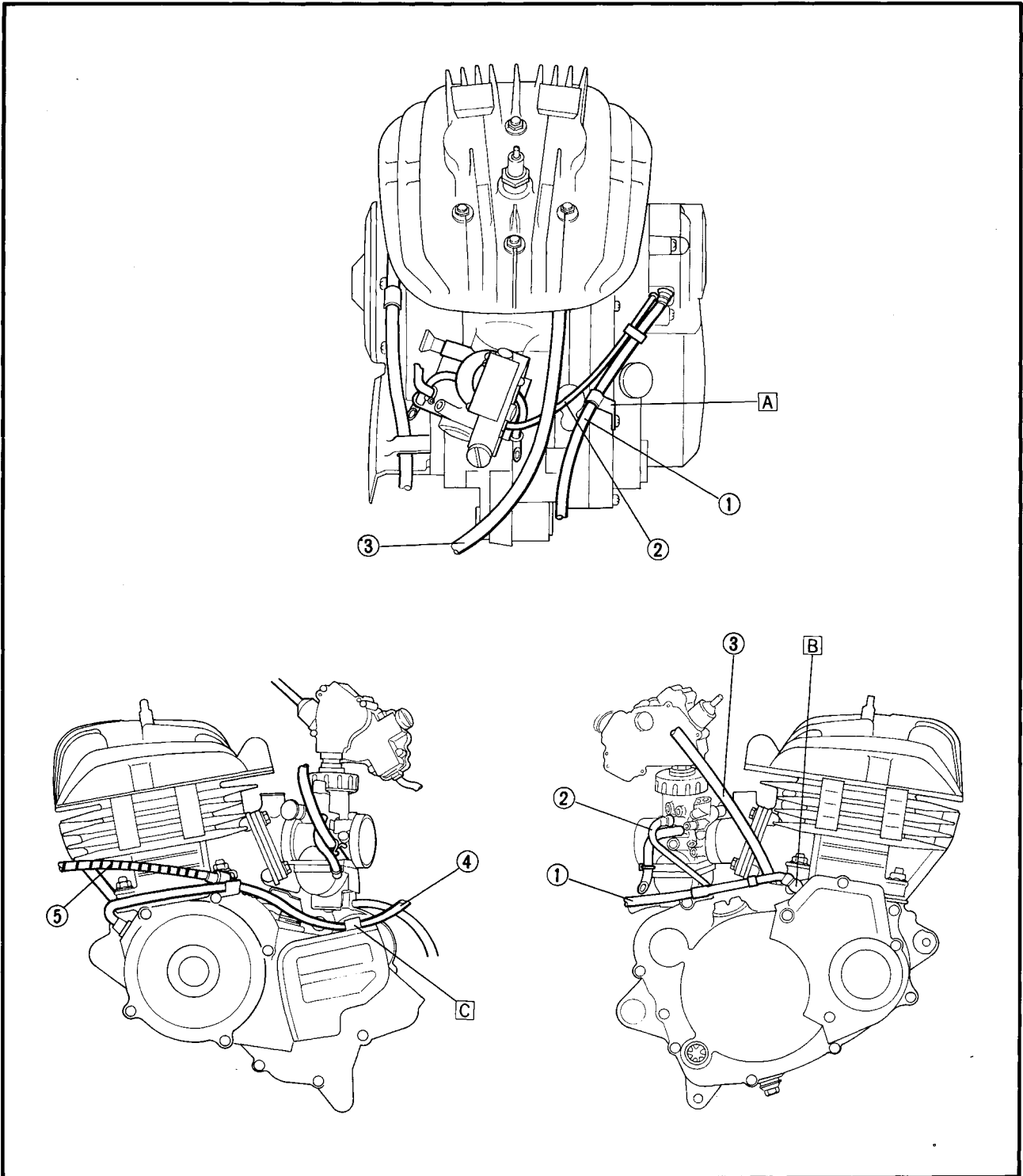

PERIODIC INSPECTION AND ADJUSTMENT

INTRODUCTION

This chapter includes all information necessary to perform recommended inspections and adjustments. These preventive maintenance procedures, if followed, will ensure more reliable vehicle operation and a longer service life. The need for costly overhaul work will be greatly reduced. This information applies to vehicles already in service as well as new vehicles that are being prepared for sale. All service technicians should be familiar with this entire chapter.

PERIODIC MAINTENANCE/LUBRICATION

Item	Remarks	Initial			Every	
		1 month	3 month	6 month	6 month	1 year
Transmission	Replace oil.	○		○	○	○
Spark plug	Check condition. Clean or replace if necessary.	○	○	○	○	○
Air filter	Clean and oil. Replace if necessary.		○	○	○	○
Carburetor	Check idle speed/starter operation. Adjust if necessary.		○	○	○	○
Fuel line	Check fuel hose for cracks or damage. Replace if necessary.			○	○	○
Throttle operation	Inspect.	○	○	○	○	○
Front brake operation	Inspect and adjust free play if necessary.	○	○	○	○	○
Front brake shoes	Check wear limit. Replace if necessary.			○	○	○
Rear brake pad	Check pad wear. Replace if necessary.			○	○	○
Clutch	Inspect free play and operation. Replace if necessary.	○		○	○	○
Drive chain	Lubricate, free play, alignment. Replace if necessary.	○		○	○	○
Drive chain guard and rollers	Check wear and replace if necessary.			○	○	○
Steering system	Inspect free play, clean and lube.	○	○	○	○	○
Front and Rear suspension	Inspect and lubricate.	○	○	○	○	○
Tire, wheels	Inspect air pressure, wheel run-out, and tire wear. Inspect bearings. Replace bearings if necessary.	○	○	○	○	○
Throttle, control cable	Check routing and connection. Lubricate.	○	○	○	○	○
Outside nut and bolts	Retighten.	○	○	○	○	○
Frame	Clean and inspect.		○	○	○	○
Lighting equipment	Inspect.	○	○	○	○	○

3

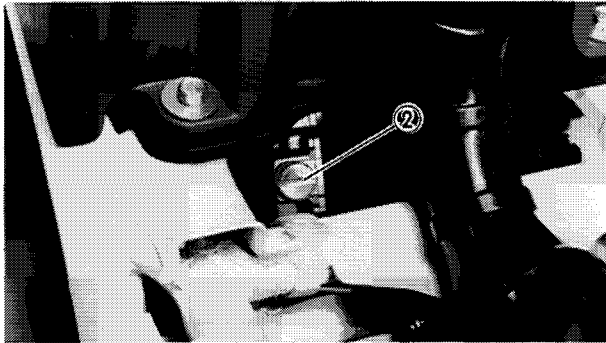
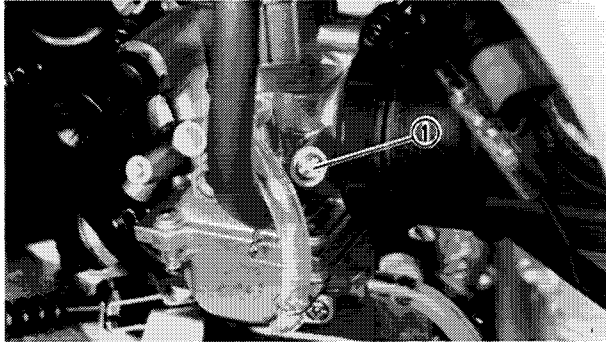
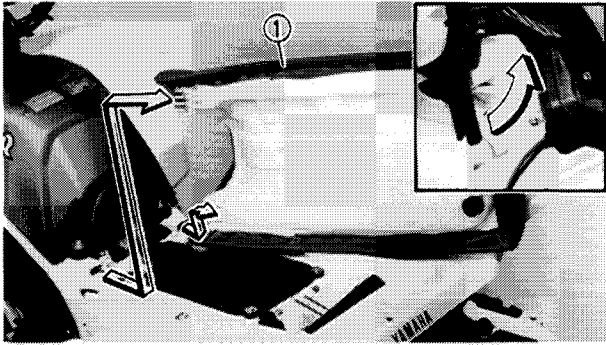

3

ENGINE

IDLE SPEED ADJUSTMENT

1. Remove:
 - Seat ①
2. Warm up engine for a few minutes.
3. Adjust:
 - Engine Idle speed

Adjustment steps:

- Turn the pilot air screw ① clockwise until it is lightly seated.
- Loosen the pilot air screw by turning it counterclockwise for the specified number of turns.

Pilot Air Screw:
1-1/2 counterclockwise turns

- Turn the throttle stop screw ② until the Idle speed is in the specified range. Use the Inductive Tachometer.

Clockwise	Idle speed becomes higher.
Counterclockwise	Idle speed becomes lower.



Inductive Tachometer:
P/N. YU-03082
P/N. 90890-03113



Engine Idle Speed:
1,450 ~ 1,550 r/min

- Turn the pilot air screw ① clockwise or counterclockwise in 1/8-turn increments to achieve the highest speed with just the pilot air screw.
- Once again, turn the throttle stop screw ② to attain the specified Idle speed.

4. Install:
 - Seat
5. Check:
 - Throttle cable free play
Refer to "THROTTLE CABLE FREE PLAY ADJUSTMENT" section.

THROTTLE CABLE FREE PLAY ADJUSTMENT

NOTE: _____
Before adjusting the throttle cable free play, the engine idle speed should be adjusted.

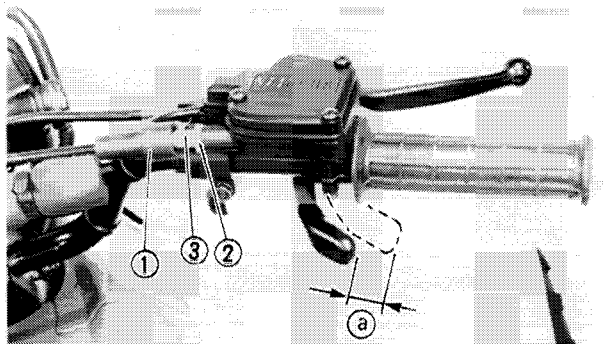

Throttle Cable Free Play:
4 ~ 6 mm (0.16 ~ 0.24 in)

3

2. Adjust:
- Throttle cable free play

Adjustment steps:

- Pull back the adjuster cover ① .
- Loosen the locknut ② .
- Turn the adjuster ③ clockwise or counterclockwise until proper free play is attained.

Clockwise	Free play is increased.
Counterclockwise	Free play is decreased.

- Tighten the locknut.

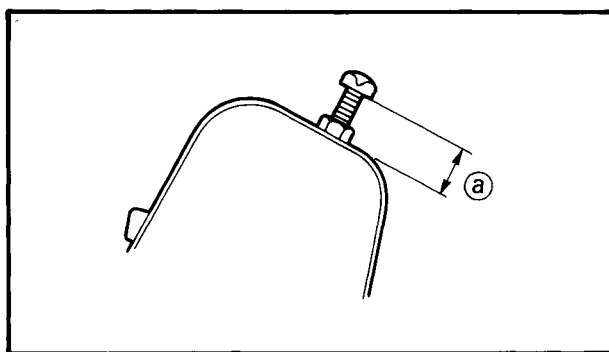

SPEED LIMITER ADJUSTMENT

The speed limiter keeps the carburetor throttle from becoming full-open even when the throttle lever is turned to a maximum. Screwing in the adjuster stops the engine speed from increasing.

1. Adjust:
- Speed limiter length ①

Adjustment steps:

- Loosen the locknut ① .
- Turn the adjuster ② clockwise or counterclockwise until proper length is attained.



Speed Limiter Length:
12 mm (0.47 in)

- Tighten the locknut ① .

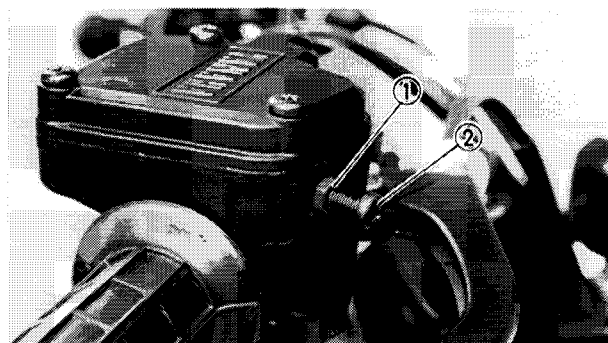

3

⚠ WARNING:

- Particularly for a beginner rider, the speed limiter should be screwed in completely. Screw it out little by little as his riding technique improves. Never remove the speed limiter from the outset.
- For proper throttle lever operation do not turn out the adjuster more than 12 mm (0.47 in). Also adjust the throttle lever free play always to 4 ~ 6 mm (0.16 ~ 0.24 in).

AUTOLUBE PUMP AIR BLEEDING

⚠ CAUTION:

The autolube pump and delivery line must be bled on the following occasions:

- Any portion of the oil system has been disconnected.
- The machine has been turned on its side.
- Whenever the oil tank has been run empty.

1. Remove:
 - Seat
2. Fill:
 - Oil tank ①

	Yamalube "2" or air-cooled 2-stroke engine oil
---	--

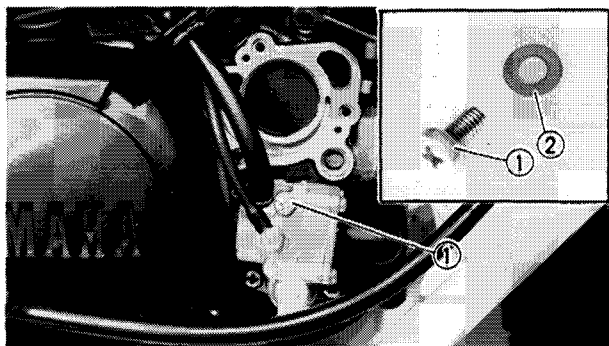
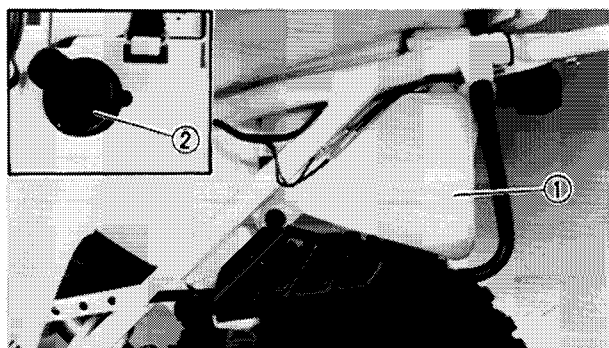

- ② Oil tank filler cap
3. Remove:
 - Autolube pump cover
4. Place a rag or oil pan under the autolube pump to catch oil.
5. Remove:
 - Bleed screw ①
6. Inspect:
 - Gasket ② (Bleed screw)
 - Damage → Replace.

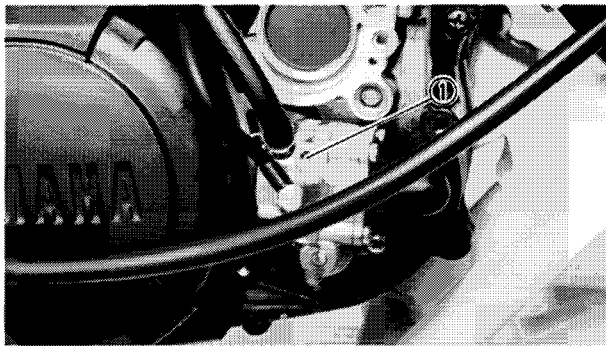

7. Keep the oil running out until air bubbles disappear from the oil hose and bleed hole ① .

8. Install:

- Gasket (Bleed screw)
- Bleed screw

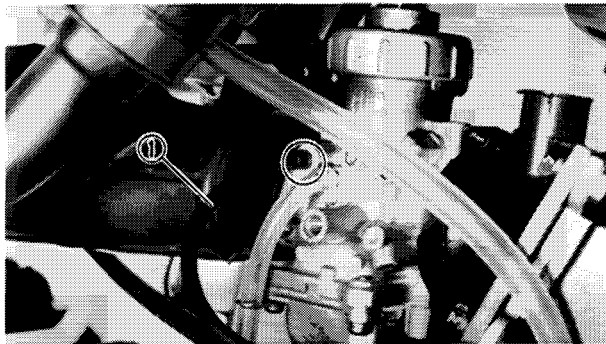

9. Disconnect:

- Oil delivery hose ① (from carburetor side)

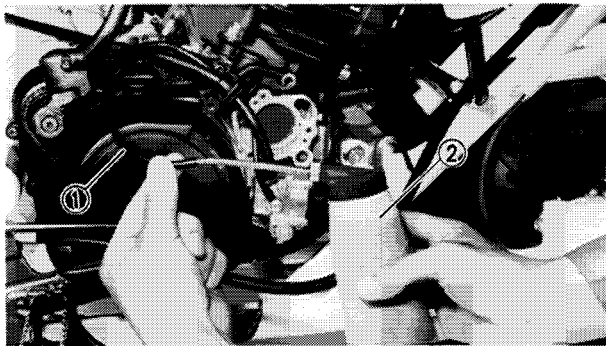

10. Feed the Yamalube "2" or air-cooled 2-stroke engine oil into the oil delivery hose ① using an oil can ② for complete air bleeding.

11. Connect:

- Oil delivery hose (to carburetor)

NOTE: _____
Thoroughly clean the engine exterior of oil.

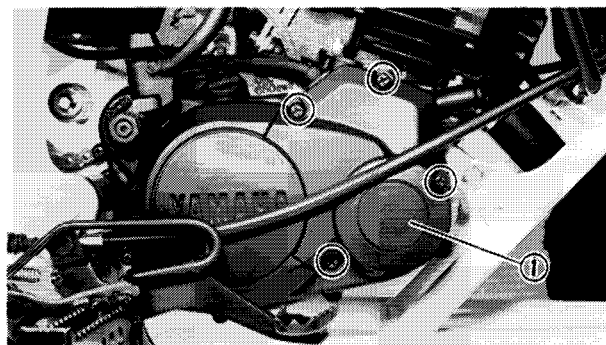

12. Install:

- Autolube pump cover ①

	Screw (Autolube Pump Cover): 7 Nm (0.7 m·kg, 5.1 ft·lb)
---	---

13. Install:

- Seat



SPARK PLUG INSPECTION

1. Inspect:
 - Spark plug type
Incorrect → Replace.

Standard Spark Plug:

- For U.S.A., Oceania
D8ES (NGK) or W24ES (NIPPONDENSO)
- For CANADA, S. Africa
DP8ES (NGK)

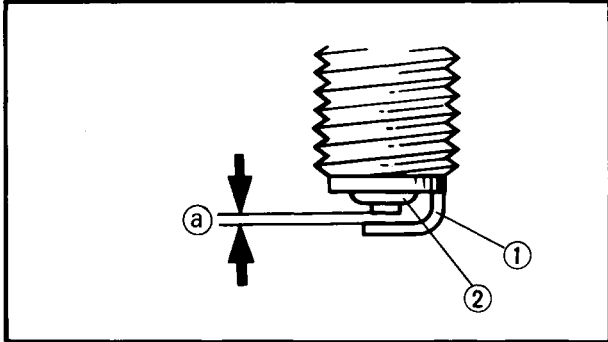

3

2. Inspect:
 - Electrode ①
Wear/Damage → Replace.
 - Insulator color ②
Normal condition is a medium to light tan color.
Distinctly different color → Check the engine condition.
3. Clean:
 - Spark plug
Clean the spark plug with a spark plug cleaner or wire brush.
4. Measure:
 - Spark plug gap ⓐ
Out of specification → Regap.
Use a wire gauge.



Spark Plug Gap:
0.7 ~ 0.8 mm (0.028 ~ 0.032 in)

5. Tighten:
 - Spark plug

NOTE: _____
Before installing a spark plug, clean the gasket surface and plug surface.



Spark Plug:
25 Nm (2.5 m·kg, 18 ft·lb)

NOTE: _____
If a torque wrench is not available when you are installing a spark plug, a good estimate of the correct torque is 1/4 to 1/2 turns part finger tight. Have the spark plug torqued to the correct value as soon as possible with a torque wrench.

IGNITION TIMING CHECK

Adjustment free

ENGINE OIL LEVEL INSPECTION

1. Place the machine on a level place.
2. Start the engine, and let it warm up.
3. Inspect:
 - Engine oil level
 Oil level low → Add sufficient oil.



Recommended Oil:
Yamalube 2-cycle oil or air-cooled 2-stroke engine oil

Oil quantity:
Total amount:
1.3 L (1.14 Imp qt, 1.37 US qt)

3

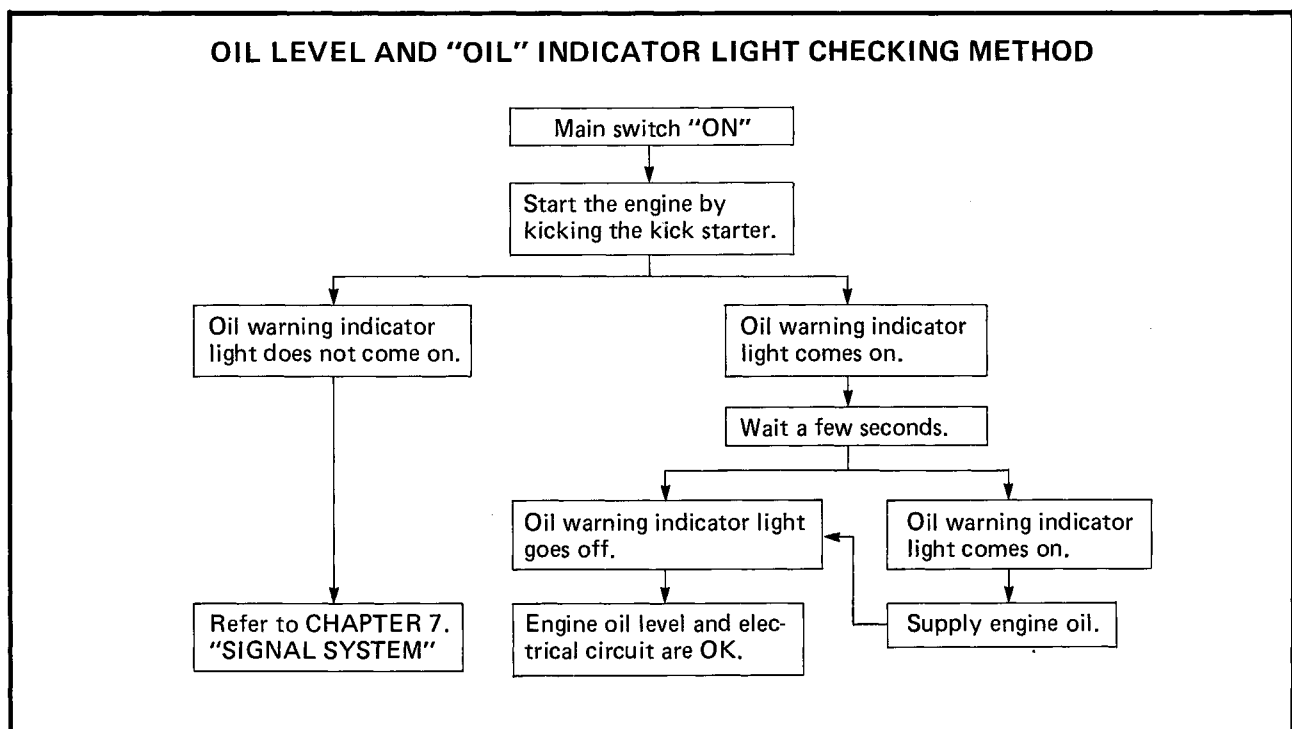

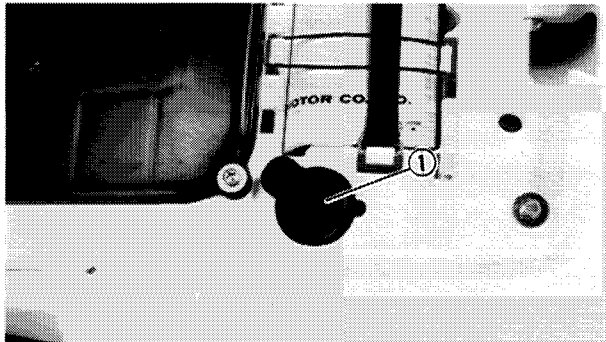
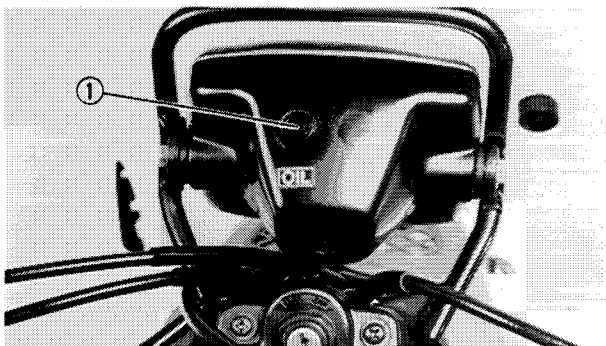

3

NOTE: _____
If the main switch is turned off after the "OIL" warning light ① goes out and then immediately again the main switch is turned on, the "OIL" warning light may not come on. This is not because of failure.

CAUTION: _____
Always use the same type of engine oil; mixing oils may result in a harmful chemical reaction and lead to poor performance.

NOTE: _____
Be sure to push the filler cap ① into the filler neck until it is properly seated.

TRANSMISSION OIL LEVEL INSPECTION

1. Inspect:
- Transmission oil level
 - Oil level low → Add sufficient oil.

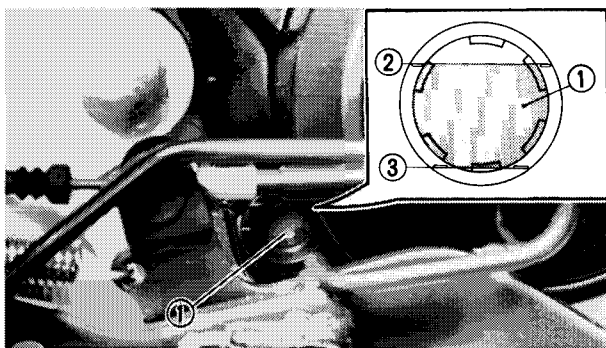

Transmission oil level inspection steps:

- Place the machine on a level place.
- Warm up the engine for several minutes, and stop it.
- Visually check the oil level through the level window ① .

NOTE: _____
The oil level should be confirmed between maximum ② and minimum ③ marks.

- If the oil level is lower, then add sufficient oil to raise it to the proper level.



Recommended Oil:
Yamalube 4 (10W-30) or SAE 10W30 type SE motor oil.

CAUTION: _____

- Do not add any chemical additives. Transmission oil also lubricates the clutch and additives could cause clutch slippage.
- Be sure no foreign material enters the crankcase.

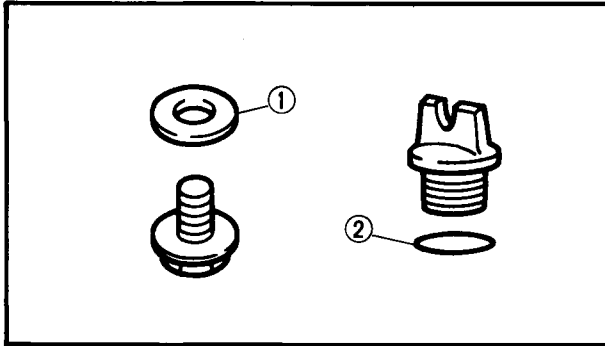
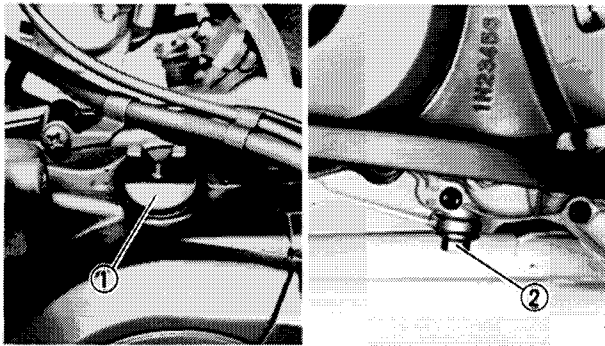

TRANSMISSION OIL REPLACEMENT

1. Place the machine on a level place.
2. Warm up the engine for several minutes, and stop it.
3. Place an oil pan under the engine.
4. Remove:
 - Filler plug ①
 - Drain plug ②
 Drain the transmission oil.
5. Inspect:
 - Gasket ① (Drain plug)
 - O-ring ② (Filler plug)
 Damage → Replace.
6. Tighten:
 - Drain plug

	Drain Plug: 20 Nm (2.0 m·kg, 14 ft·lb)
---	--

3

7. Fill:
 - Crankcase

	Recommended Oil: Yamalube 4 (10W-30) or SAE 10W30 type SE motor oil Periodic Oil Change: 0.65 L (0.57 Imp qt, 0.69 US qt)
--	---

⚠ CAUTION:

- Do not add any chemical additives. Transmission oil also lubricates the clutch and additives could cause clutch slippage.
- Be sure no foreign material enters the crankcase.

8. Install:
 - Filler plug
9. Inspect:
 - Oil leaks
 - Oil level

NOTE: _____
 Wipe off any oil spilled on the crankcase.



CLUTCH ADJUSTMENT

Clutch Cable Free Play Adjustment

1. Pull back the adjuster cover ① .

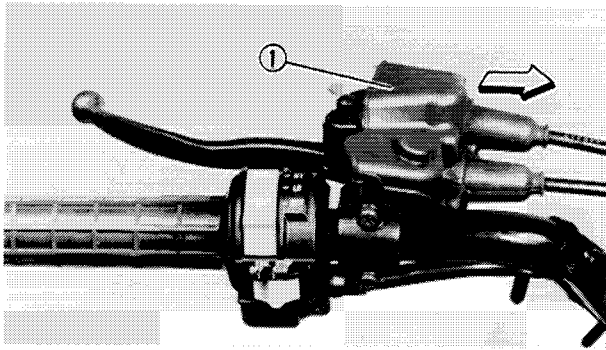

2. Check:

- Clutch cable free play ②
- Out of specification → Adjust.



Clutch Cable Free Play:
5 ~ 8 mm (0.20 ~ 0.31 in)

3. Adjust:

- Clutch cable free play

Adjustment steps:

- Loosen the locknut ① .
- Turn the adjuster ② clockwise or counter-clockwise until proper free play is attained.

Clockwise	Free play is increased.
Counterclockwise	Free play is decreased.

- Tighten the locknut.

4. Set the adjuster cover.

Mechanism Adjustment

1. Drain the transmission oil.

Refer to the "TRANSMISSION OIL REPLACEMENT" section.

2. Pull back the adjuster cover.

3. Loosen:

- Clutch cable ①

4. Disconnect:

- Parking brake cable ②
(from parking brake cable holder ③)

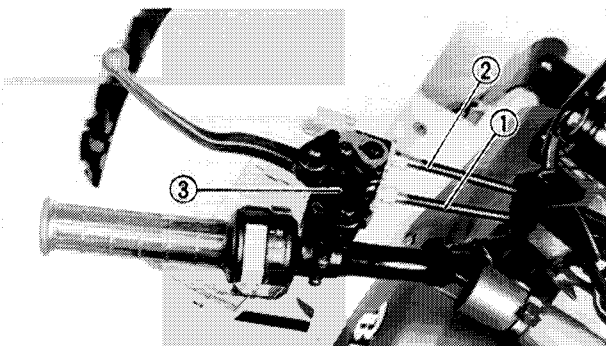
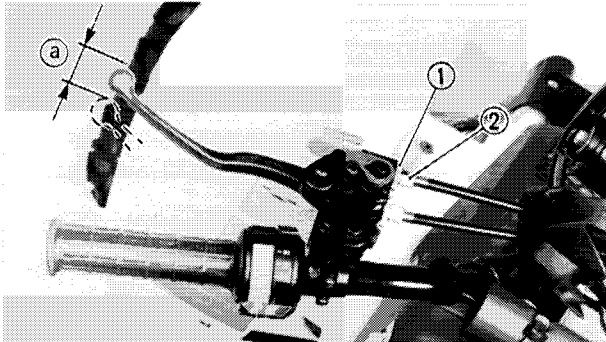

3

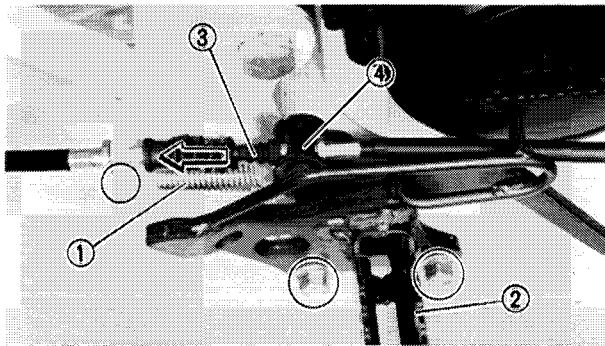

5. Disconnect:
 - Spring ①
6. Remove:
 - Footrest ② (Right)
(with rear brake pedal)
7. Pull back the brake cable stopper cover ③ .
8. Remove:
 - Pin ④ (Parking brake cable)

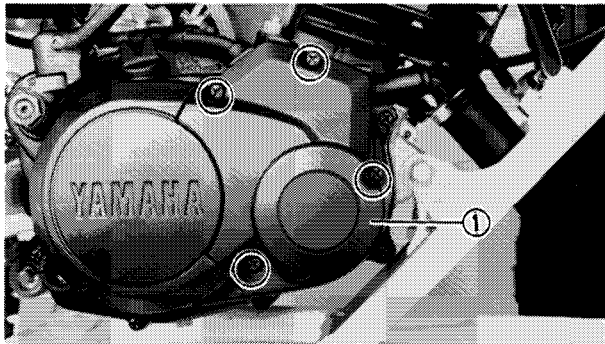

9. Remove:
 - Autolube pump cover ①

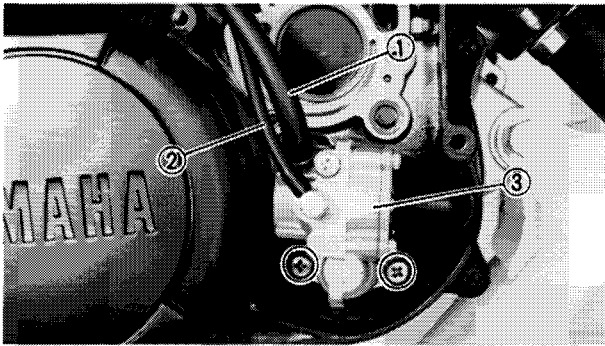

10. Disconnect:
 - Oil hose ①
 - Oil delivery hose ②

NOTE: _____
 Plug the oil hose ① so that oil does not run out of the oil tank.

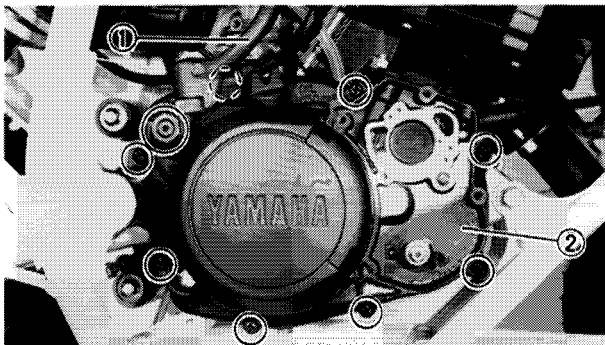

11. Remove:
 - Autolube pump ③
 - Gasket (Autolube pump)
12. Remove:
 - Kick crank ①
 - Crankcase cover (Right) ②
 - Dowel pin
 - Gasket (Crankcase cover)

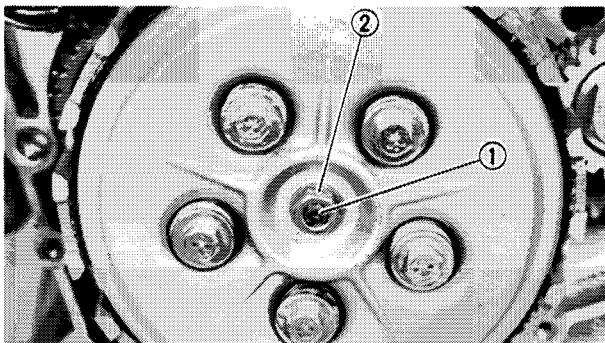

13. Adjust:
 - Adjuster ① (Push rod #1)

Adjustment steps:

- Loosen the locknut ② .
- Move the push lever ③ toward the front with your finger until it stops.

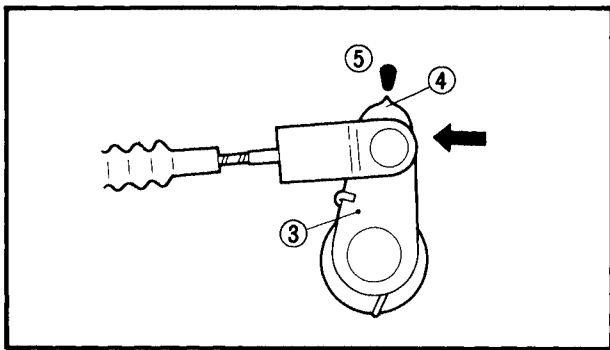

- With the push lever in this position, turn the adjuster ① to align the mark ④ on the end of the push lever with the mark ⑤ (protruberance) on the crankcase.
- Tighten the locknut ② .



Locknut:
7 Nm (0.7 m·kg, 5.1 ft·lb)

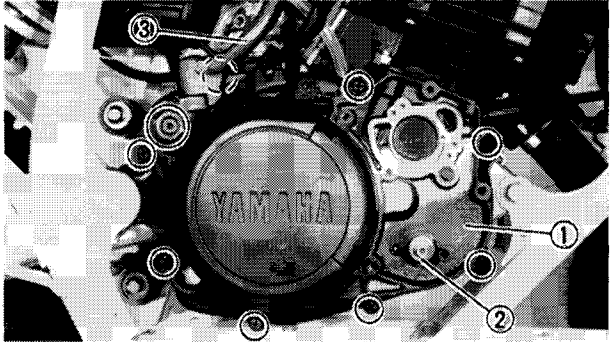

3

14. Install:

- Dowel pin
- Gasket (Crankcase cover)
- Crankcase cover ① (Right)

NOTE:

- When installing the crankcase cover, engage the autolube pump drive gear with its driven gear as slowly turn the autolube pump shaft ② .
- Tighten the crankcase cover holding screws in stage, using a crisscross pattern.



Screw (Crankcase Cover):
10 Nm (1.0 m·kg, 7.2 ft·lb)

15. Install:

- Kick crank ③

NOTE:

Install the kick crank so that it does not contact the case.



Nut (Kick Crank):
65 Nm (6.5 m·kg, 47 ft·lb)

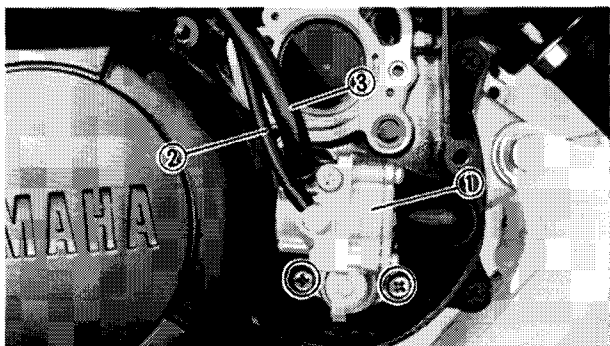

16. Install:

- Gasket (Autolube pump)
- Autolube pump ①



Screw (Autolube Pump):
5 Nm (0.5 m·kg, 3.6 ft·lb)

17. Connect:

- Oil delivery hose ②
- Oil hose ③

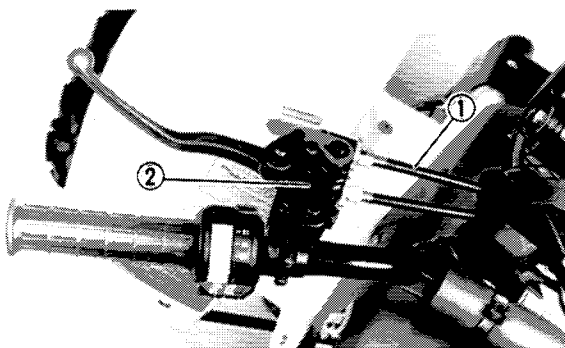
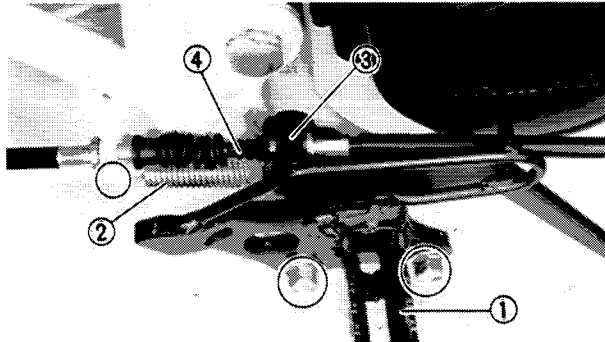
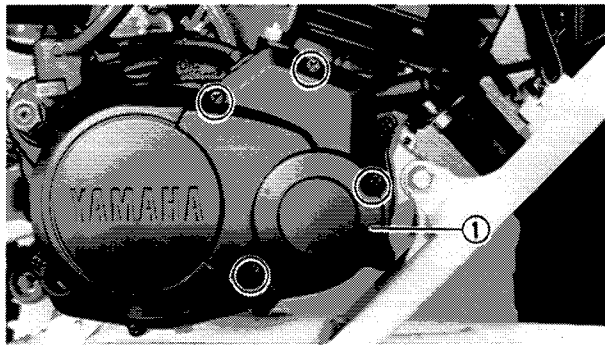

18. Perform an autolube pump air bleeding.
Refer to the "AUTOLUBE PUMP AIR BLEEDING" section.
19. Install:
 - Autolube pump cover ①

	Screw (Autolube Pump Cover): 7 Nm (0.7 m·kg, 5.1 ft·lb)
---	---

20. Install:
 - Footrest ① (Right)
(with rear brake pedal)

	Bolt (Footrest): 55 Nm (5.5 m·kg, 40 ft·lb)
---	---

3

21. Connect:
 - Spring ②
22. Install:
 - Pin ③ (Parking brake cable)
 - Cover ④ (Brake cable stopper)

23. Connect:
 - Parking brake cable ①
(to parking brake cable holder ②)
24. Set the adjuster cover.
25. Fill:
 - Crankcase
Refer to the "TRANSMISSION OIL REPLACEMENT" section.
26. Adjust:
 - Clutch cable free play
Refer to the "Clutch Cable Free Play Adjustment" section.
27. Adjust:
 - Parking brake
Refer to the "PARKING BRAKE ADJUSTMENT" section.



AIR FILTER CLEANING

NOTE:

There is a check hose ① at the bottom of the air filter case. If dust and/or water collects in this hose, clean the air filter element and air filter case.

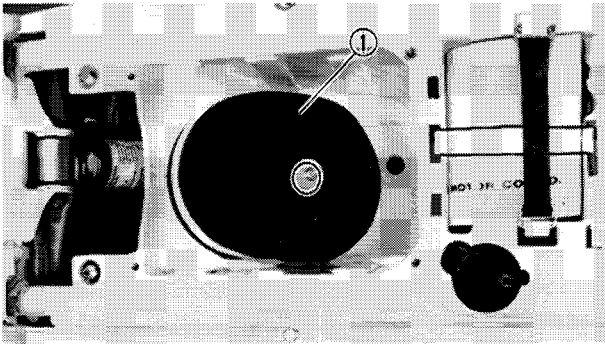
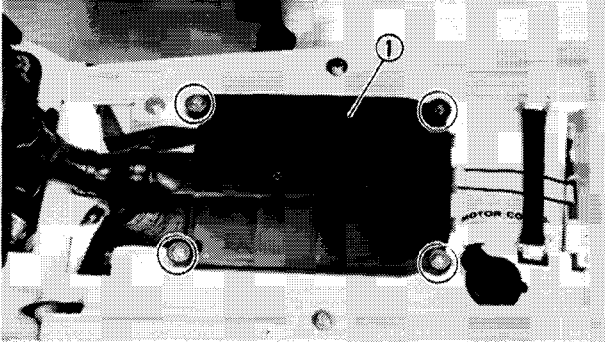
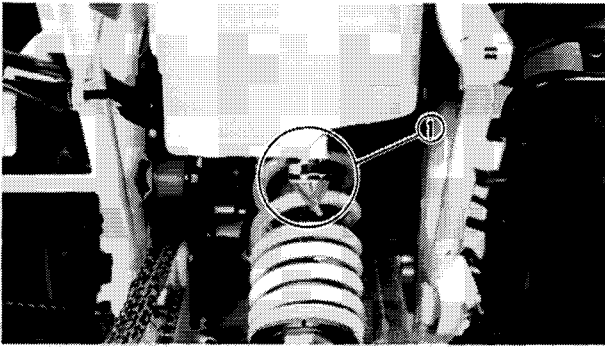

1. Remove:
 - Seat
 - Cover ① (Filter case)

2. Remove:
 - Air filter assembly ①

CAUTION:

Never operate the engine with the air filter element removed. This will allow unfiltered air to enter, causing rapid wear and possible engine damage. Additionally, operation without the filter element will affect carburetor tuning with subsequent poor performance and possible engine overheating.

3. Remove:
 - Element holder ① (from air filter element)

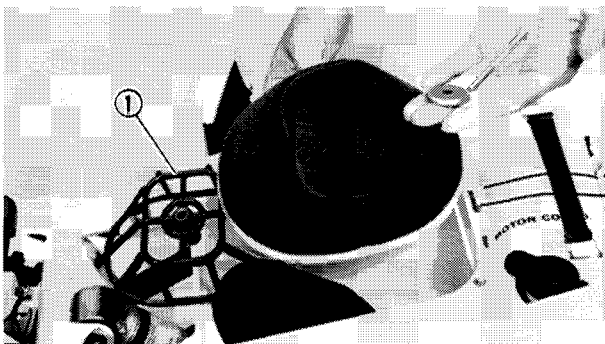

3

4. Inspect:
 - Air filter element
Damage → Replace.
5. Clean:
 - Air filter element

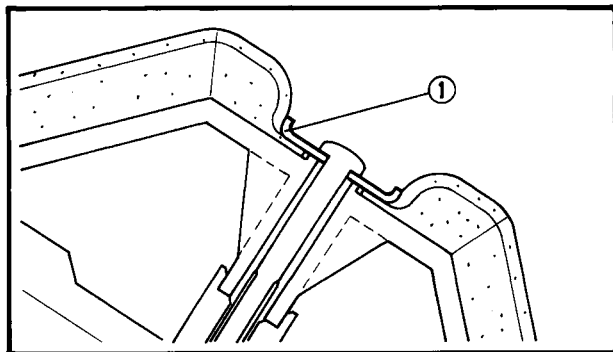
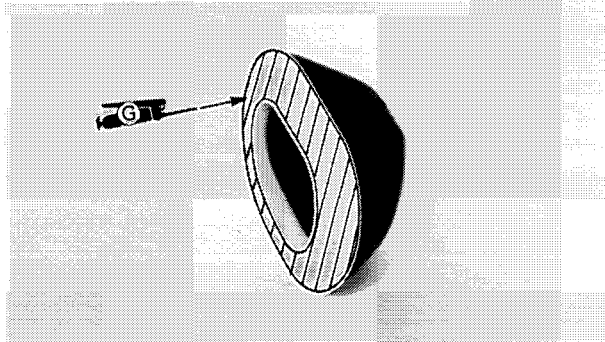

Cleaning steps:

- Wash the element with solvent.
- Remove the remaining solvent by squeezing the element.
- Apply the SAE 10W30 motor oil to the entire surface of the element.
- Wrap the element with a clean rag, and squeeze out the excess oil.

NOTE: _____
The element should be wet but not dripping.

- Apply the All-purpose grease to the element seat.

CAUTION: _____
Do not twist the filter element when squeezing the filter element.

WARNING: _____
Never use low flash point solvents such as gasoline to clean the air filter element. Such solvent may lead to a fire or explosion.

6. Clean the inside of the air filter case and the case cover, using a cloth dampened with solvent.

7. Install:
 - Air filter assembly

NOTE: _____
Install the washer ① with its bent fringe upward as shown.

8. Install:
 - Cover (Filter case)
 - Seat

CAUTION: _____
After installing the air filter element, make sure it is positioned correctly in place.

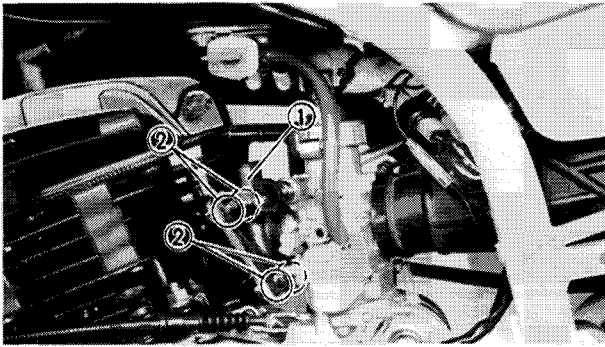

CARBURETOR JOINT INSPECTION

1. Inspect:
 - Carburetor joint ①
Cracks/Damage → Replace.
Refer to the "REED VALVE " section in the CHAPTER 5 for replacement.
2. Check the tightening torque of the carburetor joint securing bolts ② .

	Bolt (Carburetor Joint): 8 Nm (0.8 m·kg, 5.8 ft·lb)
---	---

3

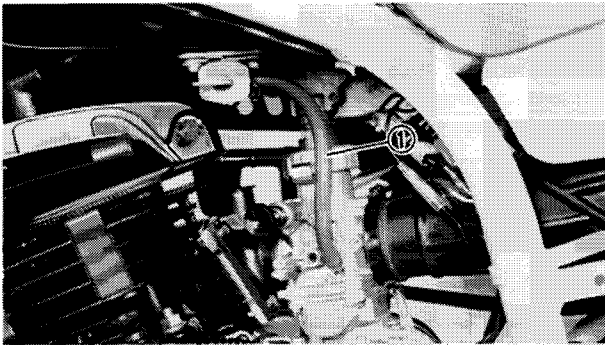

FUEL LINE INSPECTION

1. Inspect:
 - Fuel hose ①
Cracks/Damage → Replace.

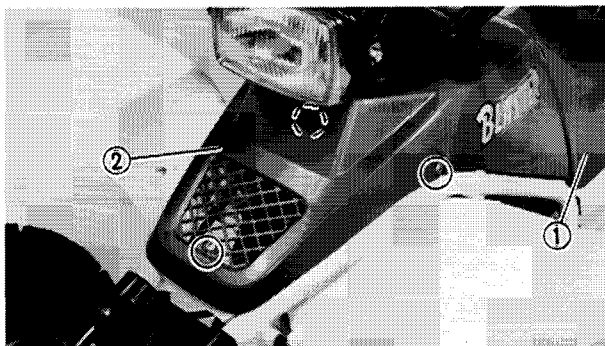

CRANKCASE VENTILATION HOSE INSPECTION

1. Turn the fuel cock to the "OFF".
2. Remove:
 - Seat ①
 - Front cover ②

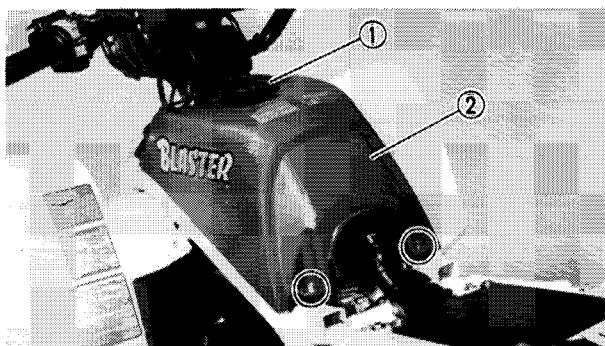

3. Remove:
 - Fuel tank cap ①
 - Fuel tank cover ②

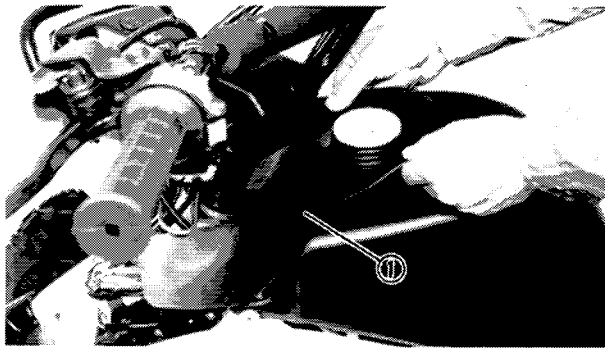

4. Remove:
 - Fuel tank cover ① (Inner)
5. Install:
 - Fuel tank cap

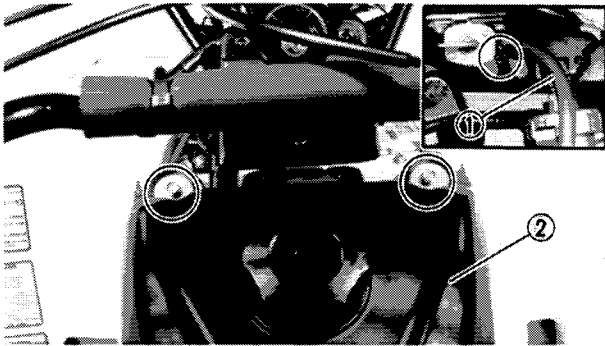

6. Disconnect:
 - Fuel hose ①
7. Remove:
 - Fuel tank ②

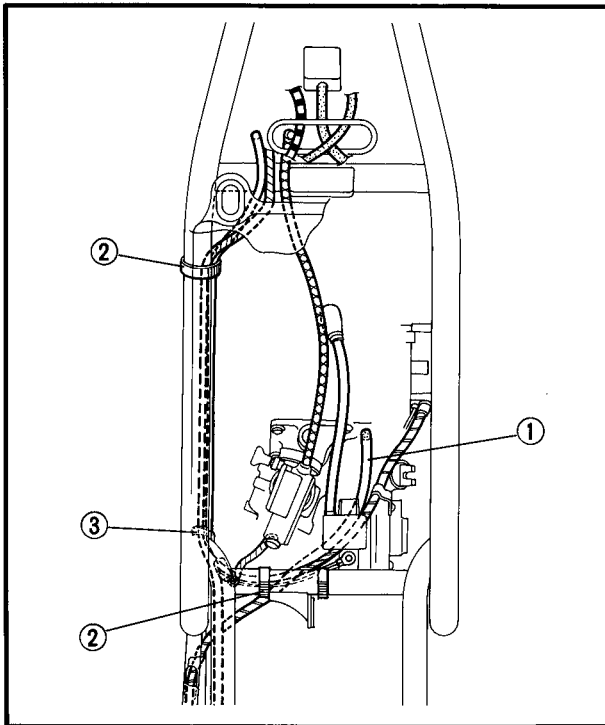

8. Inspect:
 - Crankcase ventilation hose ①
 - Cracks/Damage → Replace.

⚠ CAUTION:

Make sure the crankcase ventilation hose is routed correctly.

- ② Band
- ③ Clamp
- ④ Carburetor switch

9. Install:
 - Fuel tank
 - Fuel tank cover (Inner)
 - Fuel tank cover
 - Fuel tank cap
 - Front cover
 - Seat



Bolt (Fuel Tank):
6 Nm (0.6 m·kg, 4.3 ft·lb)

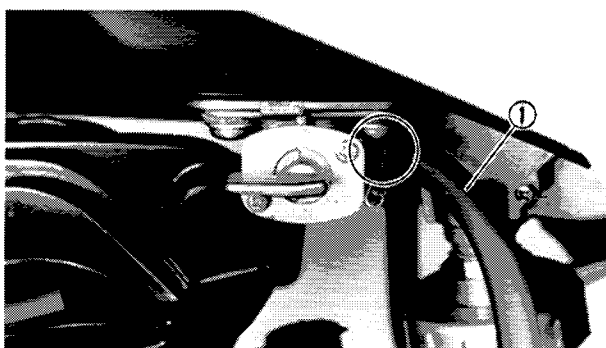

10. Connect:
- Fuel hose ①

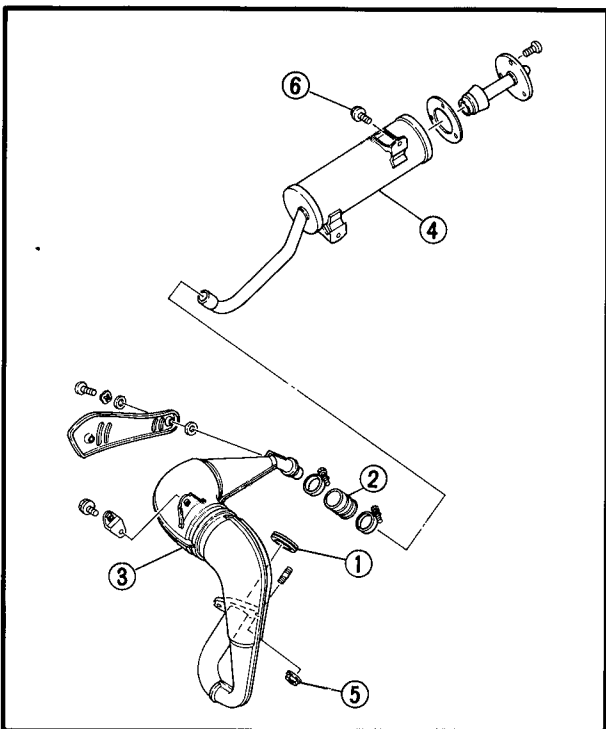

EXHAUST SYSTEM INSPECTION

1. Inspect:
- Gasket (Exhaust pipe) ①
 - Joint (Silencer) ②
 - Damage → Replace.
 - Exhaust gas leakage → Repair.
 - Exhaust pipe ③
 - Silencer ④
 - Cracked/Dent/Damage → Repair or replace.
2. Tighten:
- Exhaust pipe
 - Silencer

	Nut ⑤ (Exhaust pipe): 21 Nm (2.1 m·kg, 15 ft·lb)
	Bolt ⑥ (Silencer): 23 Nm (2.3 m·kg, 17 ft·lb)

3

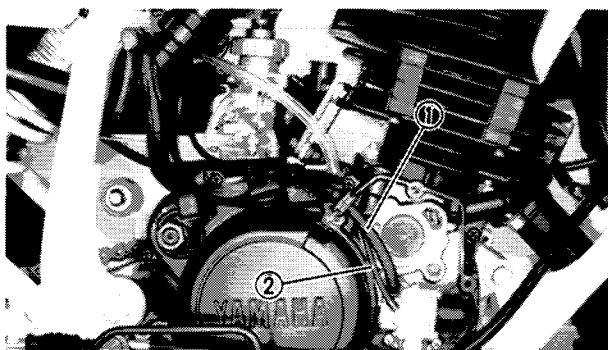

ENGINE OIL LINE INSPECTION

1. Remove:
- Autolube pump cover
2. Inspect:
- Oil hose ①
 - Oil delivery hose ②
 - Cracks/Damage → Replace.
 - Loose connection → Connect properly.

③ Engine oil tank

3. Install:
- Autolube pump cover

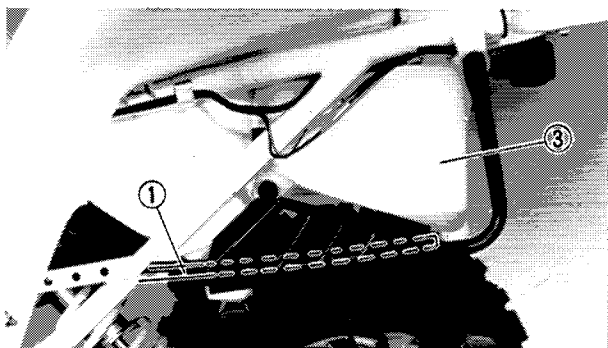

	Screw (Autolube Pump Cover) 7 Nm (0.7 m·kg, 5.1 ft·lb)
--	---

CHASSIS

FRONT BRAKE ADJUSTMENT

⚠ CAUTION:

Proper lever free play is essential to avoid excessive brake drag.

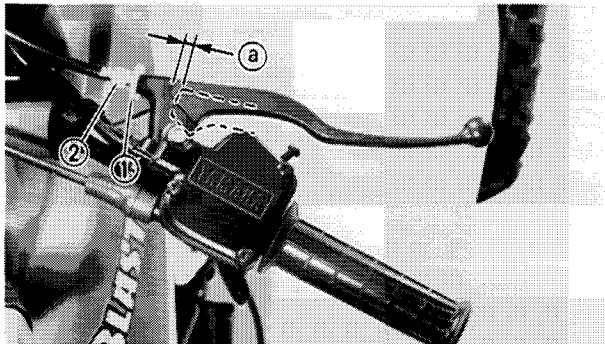

1. Check:
 - Front brake cable free play ①
 - Out of specification → Adjust.

	Front Brake Cable Free Play: 5 ~ 8 mm (0.20 ~ 0.31 in)
---	--

3



2. Adjust:
 - Front brake cable free play

Adjustment steps:

- Loosen the locknut ① and turn the adjuster ② clockwise to release the tension in the front brake cable.
- Remove the front cover ③ .
- Visually check the cable joint ④ in the equalizer ⑤ to verify it is horizontal.
- If not horizontal, turn both adjuster ⑥ (Front hub – left and right) until the cable joint ④ is horizontal.
- Turn the adjuster ② clockwise or counterclockwise until proper free play is attained.

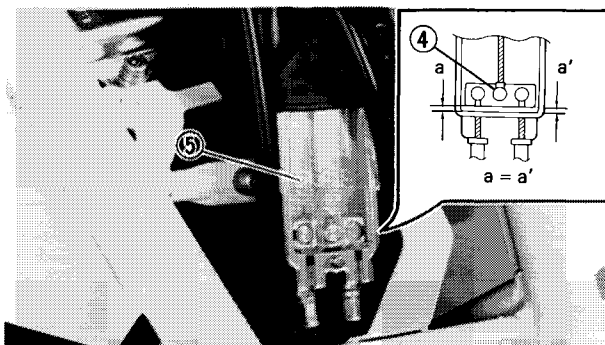

Clockwise	Free play is increased.
Counterclockwise	Free play is decreased.
• Tighten the locknut ① .	

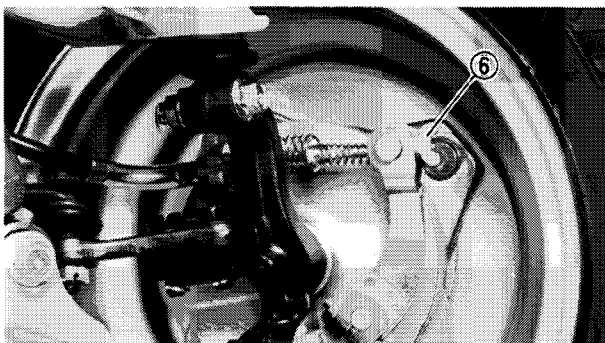

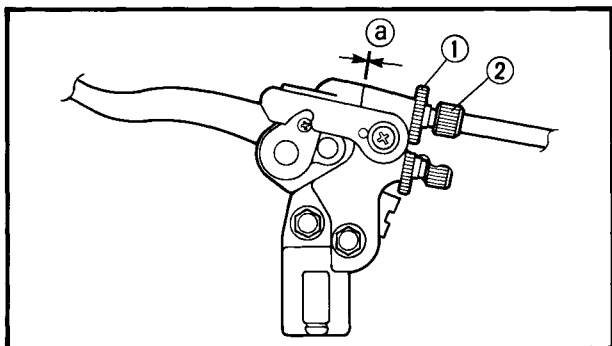

PARKING BRAKE ADJUSTMENT

1. Pull back the adjuster cover.
2. Check:
 - Parking brake cable free play (a)
 Out of specification → Adjust.

Parking Brake Cable Free Play:
0 mm (0 in)

3. Adjust:
 - Parking brake cable free play

Adjustment steps:

- Loosen the locknut (1).
- Turn the adjuster (2) counterclockwise until the parking brake cable free play (a) becomes 0, or as close to 0 as possible.
- Tighten the locknut (1).

4. Set the adjuster cover.

⚠ WARNING:

After this adjustment is performed, block the rear of the machine off the ground, and spin the rear wheels to ensure there is no brake drag. If any brake drag is noticed, perform the above steps again.

3

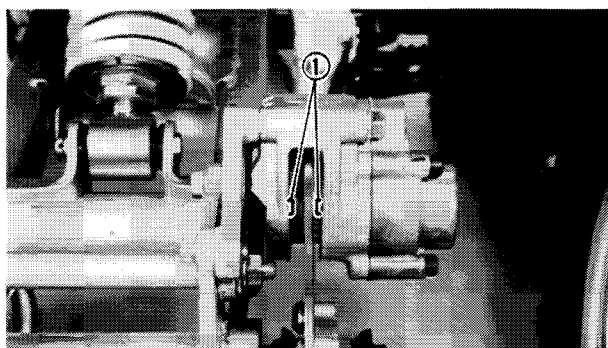

BRAKE PAD INSPECTION (REAR BRAKE)

1. Depress the brake pedal.
2. Inspect:
 - Brake pad
 Wear indicator (1) almost contacts brake disc → Replace brake pad as a set.
Refer to the "REAR BRAKE" section in the CHAPTER 6 for replacement.

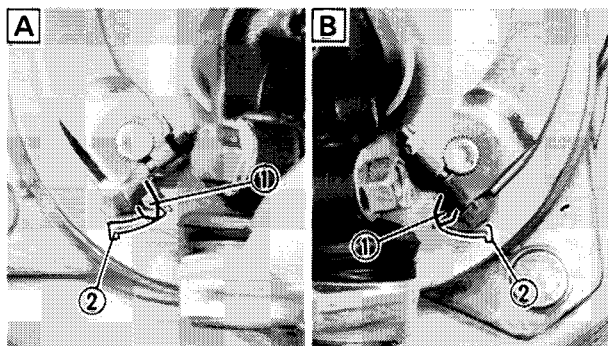

BRAKE SHOE INSPECTION (FRONT BRAKE)

1. Apply the front brake.
2. Inspect:
 - Wear indicator (1)
 Indicator reaches the wear limit line (2) → Replace brake shoes as a set.
Refer to the "FRONT WHEEL AND FRONT BRAKE" section in the CHAPTER 6 for replacement.

A Right side **B** Left side

DRIVE CHAIN SLACK ADJUSTMENT

NOTE: _____

Before checking and/or adjusting, rotate the rear wheels through several revolutions and check slack at several points to find the tightest point. Check and/or adjust the chain slack with the rear wheels in this "tightest" position.

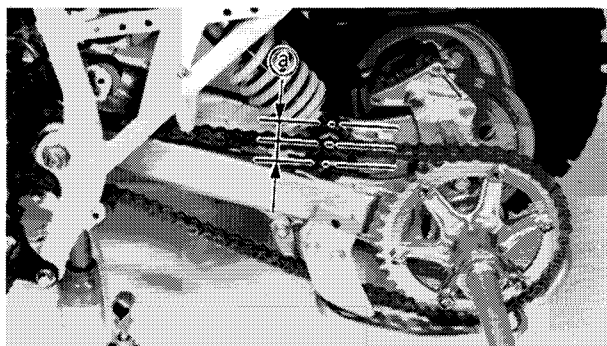

1. Elevate the rear wheels by placing a suitable stand under the rear of frame.
2. Measure:
 - Drive chain slack (a)
 - At the position shown in the photograph.
 - Out of specification → Adjust.



Drive Chain Slack:
30 ~ 40 mm (1.18 ~ 1.57 in)

3

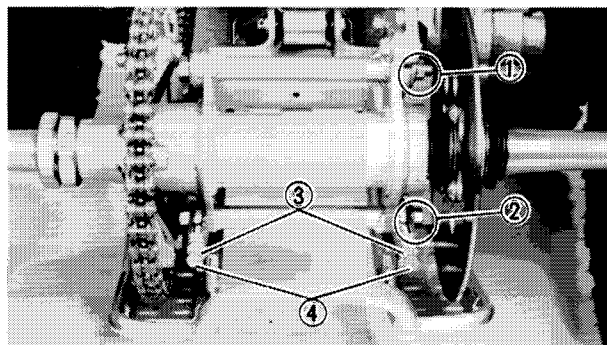

3. Adjust:
 - Drive chain slack

Adjustment steps:

⚠ CAUTION: _____

Too small chain slack will overload the engine and other vital parts; keep the slack within the specified limits.

- Loosen the rear axle hub upper nut (1) .
- Loosen the rear axle hub lower nut (2) .
- Loosen the adjuster locknut (3) .
- Adjuster chain slack by turning the adjuster (4) .

Clockwise	Slack is decreased.
-----------	---------------------

Counterclockwise (while pushing the rear axle hub to the forward)	Slack is increased.
--	---------------------

NOTE: _____

Turn each adjuster exactly the same amount to maintain correct axle alignment. (There are marks on each side of swingarm and on each chain puller; use them to check for proper alignment.)

- Tighten the rear axle hub nuts and adjuster locknuts.



Nut (Rear Axle Hub – Upper ① and Lower ②):

50 Nm (5.0 m·kg, 36 ft·lb)

Locknut ③ (Adjuster):

16 Nm (1.6 m·kg, 12 ft·lb)

DRIVE CHAIN LUBRICATION

The chain consists of many parts which work against each other. If the chain is not maintained properly, it will wear out rapidly, therefore, form the habit of periodically servicing the chain. This service is especially necessary when riding in dusty conditions.

This machine has a drive chain with small rubber O-rings between the chain plates. Steam cleaning, high-pressure washes, and certain solvents can damage these O-rings. Use only kerosene to clean the drive chain. Wipe it dry, and thoroughly lubricate it with SAE 30 ~ 50W motor oil. Do not use any other lubricants on the drive chain. They may contain solvents that could damage the O-rings.



Recommended Lubricant:
SAE 30 ~ 50 Motor Oil

STEERING SYSTEM INSPECTION

1. Place the machine on a level place.
2. Check:
 - Steering column bushings and bearings
Move the handlebar up and down, and/or back and forth.
Excessive play → Replace the steering column bushings and or bearings.
Refer to the "STEERING SYSTEM" section in the CHAPTER 6.
3. Check:
 - Tie-rod ends
Turn the handlebar to the left and/or right until it stops completely, then slightly move the handlebar from left to right.
Tie-rod end ① has any vertical play → Replace the tie-rod end(s).
Refer to the "STEERING SYSTEM" section in the CHAPTER 6.

3

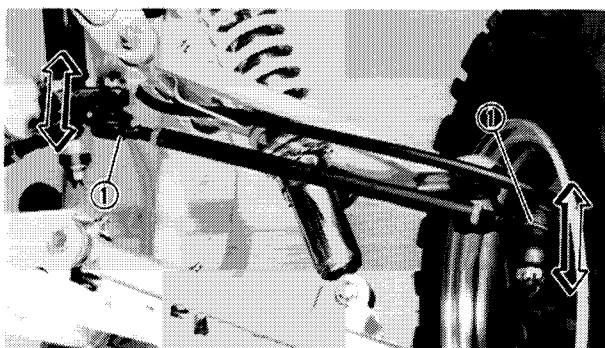

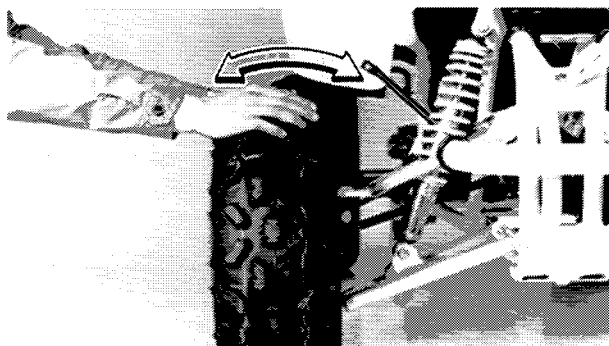

4. Raise the front end of the machine so that there is no weight on the front wheels.
5. Check:
 - Ball joints and/or wheel bearings
Move the wheels laterally back and forth. Excessive free play → Replace the front arms and/or wheel bearings. Refer to the "FRONT SHOCK ABSORBER AND FRONT ARMS" and "FRONT WHEEL AND FRONT BRAKE" section in the CHAPTER 6.

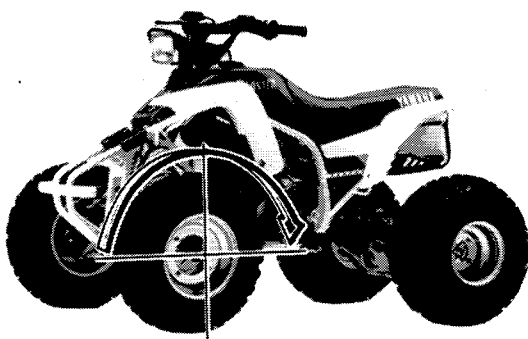
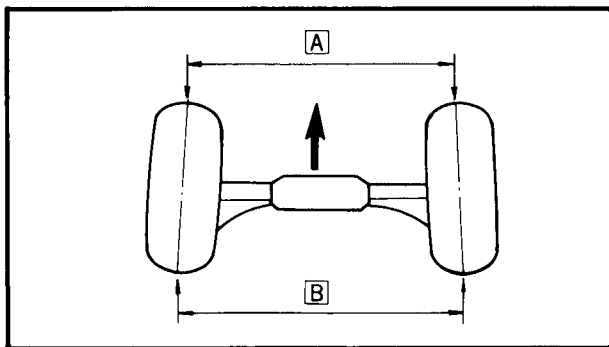

TOE-IN ADJUSTMENT

1. Place the machine on a level place.
2. Measure:
 - Toe-in
Out of specification → Adjust.

Toe-in measurement steps:

- Mark both front tire tread centers.
- Raise the front end of the machine so that there is no weight on the front tires.
- Fix the handlebar straight ahead.
- Measure the width **A** between the marks.
- Rotate the front tires 180 degrees until the marks come exactly opposite.
- Measure the width **B** between the marks.
- Calculate the toe-in using the formula given below.

$$\text{Toe-in} = \text{B} - \text{A}$$



Toe-in:
0 ~ 10 mm (0 ~ 0.39 in)

- If the toe-in is incorrect, adjust the toe-in.

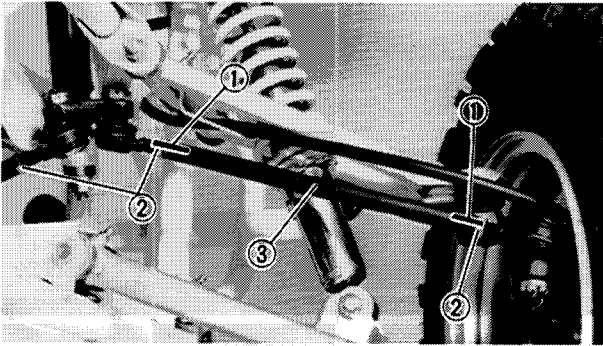

3. Adjust:

- Toe-in

Adjustment steps:

- Place a confirmation marks ① on the both tie-rods end.
- Loosen the rod end locknuts ② of both tie-rods.
- The same number of turns should be given to both tie-rods ③ right and left until the specified toe-in is obtained, so that the lengths of the rods will be kept the same.
- Tighten the rod end locknuts ② of both tie-rods.



Locknut (Rod end):
30 Nm (3.0 m·kg, 22 ft·lb)
USE LOCTITE®

⚠ WARNING:

- Be sure that both tie-rods are turned by the same amount. If not, the machine will go right or left even though the handlebar is positioned straight and it may lead to mis-handling and accident.
- After setting the toe-in to specification, run the machine slowly for some distance with the hands lightly on the handlebar and check that the handlebar responds correctly. If not, turn either the right or left tie-rod within the toe-in specification.

3

FRONT SHOCK ABSORBER ADJUSTMENT

⚠ WARNING:

Always adjust both front shock absorber spring preload to the same setting. Uneven adjustment can cause poor handling and loss of stability.

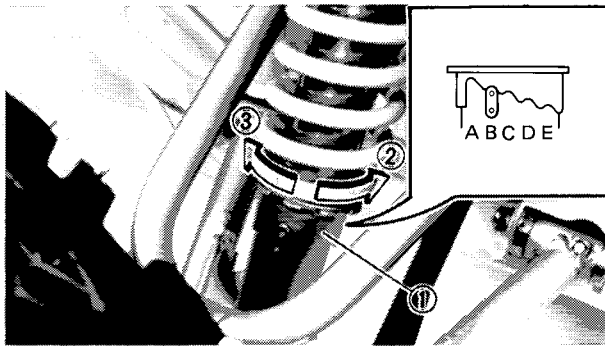

1. Adjust:
- Spring preload
Turn the adjuster ① to increase or decrease the spring preload.

Front Shock Absorber Preload			
Preload	Softer ② ←	Standard	Stiffer ③ →
Position	A	B	C, D, E

REAR SHOCK ABSORBER ADJUSTMENT

⚠ WARNING:

This shock absorber contains highly pressurized nitrogen gas. Read and understand the following information before handling the shock absorber. The manufacture cannot be held responsible for property damage or personal injury that may result from improper handling.

- Do not tamper with or attempt to open the cylinder assembly.
- Do not subject shock absorber to an open flame or other high heat source. This may cause the unit to explode due to excessive gas pressure.
- Do not deform or damage the cylinder in any way. Cylinder damage will result in poor damping performance.

3

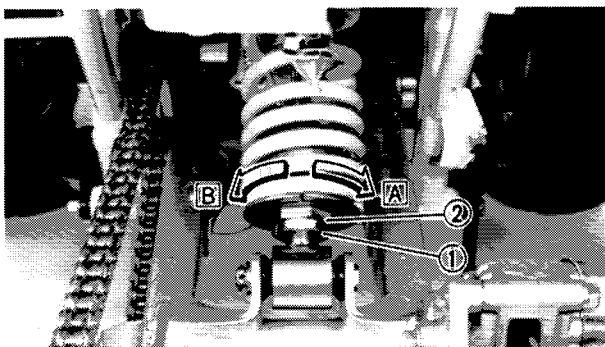

1. Adjust:
- Spring preload

Adjustment steps:	
<ul style="list-style-type: none"> • Elevate the rear wheels by placing the suitable stand. • Loosen the locknut ①. • Adjust the spring preload. 	
NOTE:	
The length of the spring (Installed) changes 1.5 mm (0.06 in) per turn of the adjuster.	
Turn adjuster ② clockwise A	Increase the spring preload.
Turn adjuster ② counterclockwise B	Decrease the spring preload.

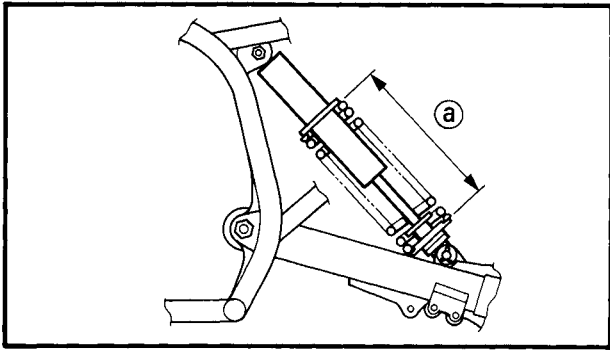

(a) Spring length



Standard Spring Length (Installed):
230 mm (9.1 in)
Minimum Length (Installed):
222 mm (8.7 in)
Maximum Length (Installed):
234 mm (9.2 in)

⚠ CAUTION:

Never attempt to turn the adjuster beyond the maximum or minimum setting.

- Tighten the locknuts.



Locknut:
55 Nm (5.5 m·kg, 40 ft·lb)

3

TIRE INSPECTION

⚠ WARNING:

This model is equipped with low pressure tires. It is important that they be inflated correctly and maintained at the proper pressures.

• TIRE CHARACTERISTICS

- 1) Tire characteristics influence the handling of ATV's. The tires listed below have been approved by Yamaha Motor Co., Ltd. for this model. If other tire combinations are used, they can adversely affect your machine's handling characteristics and are therefore not recommended.

	Manufacturer	Size	Type
Front	Dunlop	AT21 x 7-10	KT894
	Cheng shin	AT21 x 7-10	C873
Rear	Dunlop	AT21 x 10-8	KT895
	Cheng shin	AT21 x 10-8	C874

• TIRE PRESSURE

- 1) Recommended tire pressure
 Front 30 kPa (0.30 kg/cm², 4.3 psi)
 Rear 25 kPa (0.25 kg/cm², 3.6 psi)

2) Tire pressure below the minimum specified could cause the tire to dislodge from the rim under severe riding conditions.

The following are minimums:

Front 27 kPa (0.27 kg/cm², 3.8 psi)

Rear 22 kPa (0.22 kg/cm², 3.1 psi)

3) Use no more than

Front 250 kPa (2.5 kg/cm², 36 psi)

Rear 190 kPa (1.9 kg/cm², 27 psi)

When seating the tire beads. Higher pressures may cause the tire to burst.

Inflate the tires very slowly and carefully.

Fast inflation could cause the tire to burst.

• **MAXIMUM LOADING LIMIT**

1) Vehicle load limits: 100 kg (220 lb)*

*Total weight of cargo, rider, and accessories.

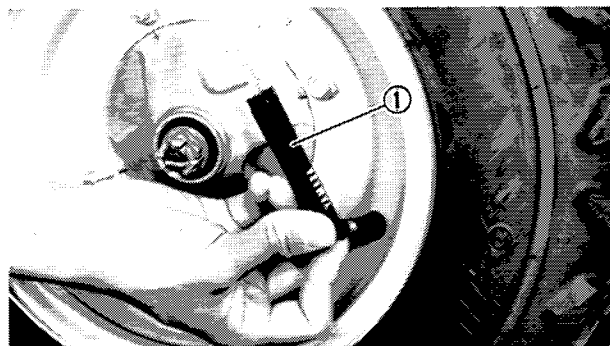

1. Measure:

- Tire pressure (Cold tire pressure)
- Out of specification → Adjust.

NOTE:

The low-pressure tire gauge ① is included in the standard equipment.

If dust or the like is stuck to this gauge, it does not provide correct readings. Therefore, make two measurements on the tire pressure and get the second reading.

Cold Tire Pressure	Front	Rear
Standard	30 kPa (0.3 kg/cm ² , 4.3 psi)	25 kPa (0.25 kg/cm ² , 3.6 psi)
Minimum	27 kPa (0.27 kg/cm ² , 3.8 psi)	22 kPa (0.22 kg/cm ² , 3.1 psi)
Maximum	33 kPa (0.33 kg/cm ² , 4.7 psi)	28 kPa (0.28 kg/cm ² , 4.0 psi)

3

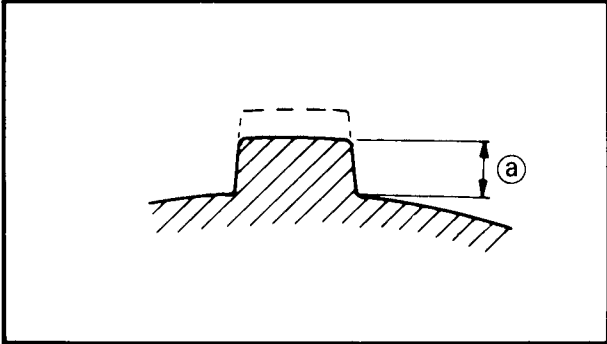

⚠ WARNING:

Uneven or improper tire pressure may adversely affect the handling of this machine and may cause loss of control.

- Maintain proper tire pressures.
- Set tire pressures when the tires are cold.
- Tire pressures must be equal in both front tires and equal in both rear tires.

2. Inspect:

- Tire surfaces
Wear/Damage → Replace.



Tire Wear Limit (a) :
Front and Rear: 3.0 mm (0.12 in)

⚠ WARNING:

It is dangerous to ride with a wornout tire. When a tire wear is out of specification, replace the tire immediately.

WHEEL INSPECTION

1. Inspect:

- Wheels
Damage/Bends → Replace.

NOTE:

Always balance the wheel when a tire or wheel has been changed or replaced.

⚠ WARNING:

- Never attempt even small repairs to the wheel.
- Ride conservatively after installing a tire to allow it to seat itself properly on the rim.

CABLE INSPECTION AND LUBRICATION

⚠ WARNING:

Damaged cable sheath may cause corrosion and interfere with the cable movement. An unsafe condition may result so replace such cable as soon as possible.

1. Inspect:
 - Cable sheath
Damage → Replace.
2. Check:
 - Cable operation
Unsmooth operation → Lubricate or replace.



Recommended Lubricant:
SAE 10W30 Motor Oil

NOTE:

Hold cable end high and apply several drops of lubricant to cable.

3. Apply the grease to the throttle cable end
① at inside of the throttle housing ② .



Lithium Soap Base Grease

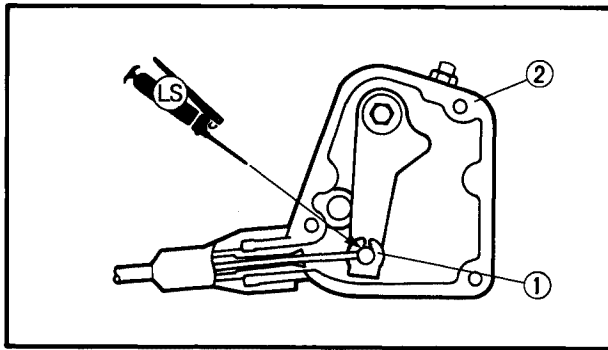

LEVER AND PEDAL LUBRICATION

1. Lubricate the pivoting parts of each lever and pedal.



Recommended Lubricant:
SAE 10W30 Motor Oil

FRONT SUSPENSION LUBRICATION

1. Inject grease from the nipples ① using a grease gun until slight over flow is observed from the thrust covers.



Lightweight Lithium-soap Base Grease

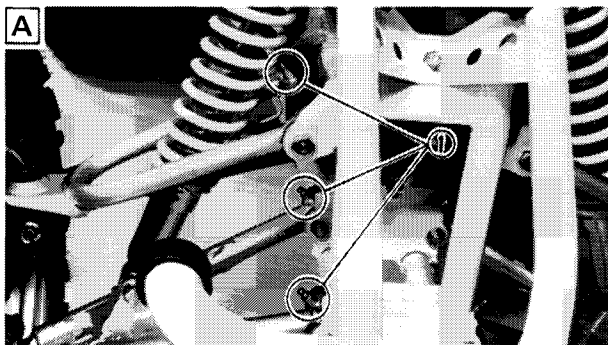

A Right side

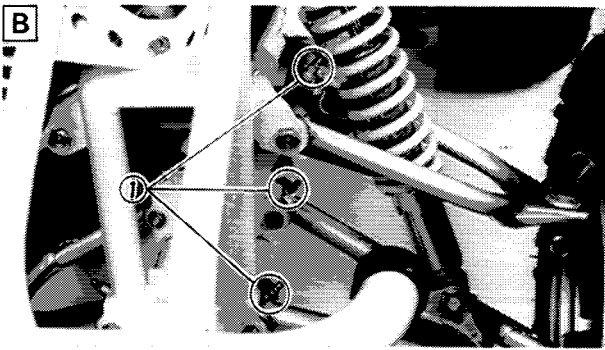

NOTE: _____
Thoroughly wipe off the excess grease.

B Left side

STEERING COLUMN BUSHING LUBRICATION

1. Inject grease from the nipple ① using a grease gun.

	Lightweight Lithium-soap Base Grease
---	---

3

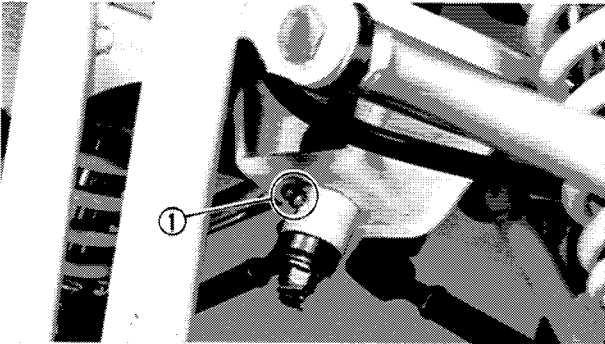

ELECTRICAL

HEADLIGHT BEAM ADJUSTMENT

1. Loosen:
 - Bolts ① (Headlight unit)
2. Adjust:
 - Headlight beam (Vertical)

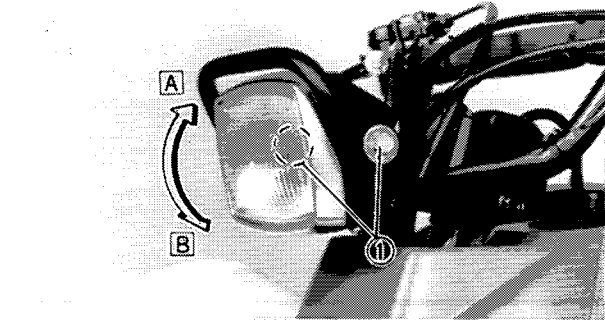

Tilt upward A	Headlight beam is higher.
Tilt downward B	Headlight beam is lower.

3. Tighten the bolts in the proper position.

HEADLIGHT BULB REPLACEMENT

1. Remove:
 - Screws ① (Headlight unit)
 - Headlight unit ②

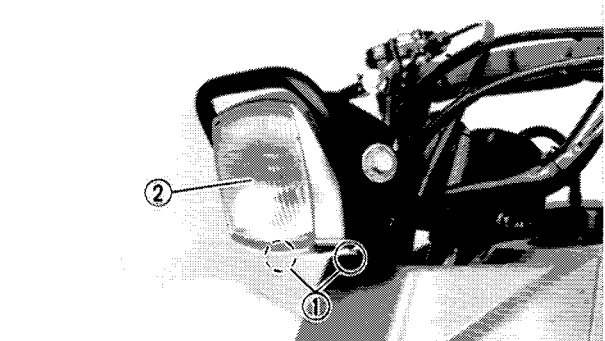

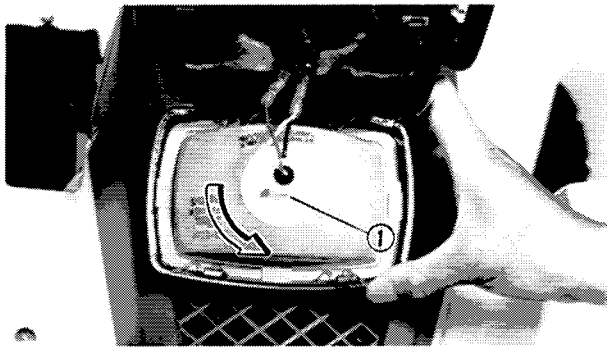

2. Remove:
 - Bulb holder ①
Turn the bulb holder ① counterclockwise.

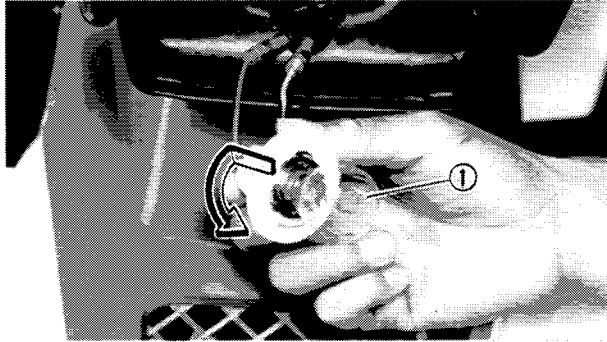

3. Remove:
 - Bulb ① (Defective)
While pushing the bulb ①, turn it counterclockwise.

⚠ WARNING:

Keep flammable products or your hands away from the bulb while it is on, it will be hot. Do not touch the bulb until it cools down.

3

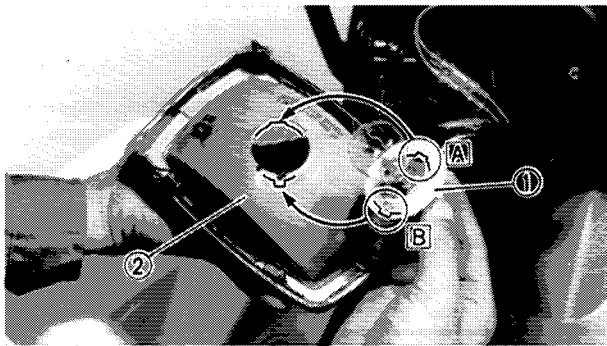

4. Install:
 - Bulb (New)
(to bulb holder)
5. Install:
 - Bulb holder ①

NOTE:

Make sure the projections (Large **A** and small **B**) on the bulb holder are meshed with the slots on the light case **2**.

6. Install:
 - Headlight unit
7. Adjust:
 - Headlight beam (Vertical)
Refer to the "HEADLIGHT BEAM ADJUSTMENT" section.

TAIL LIGHT REPLACEMENT

1. Remove:
 - Screws ① (Tail light unit)
 - Tail light unit ②

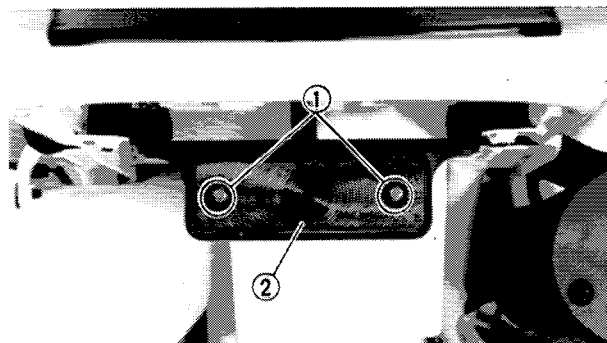

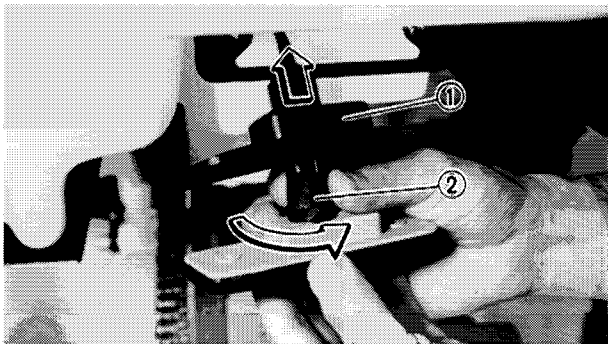

2. Pull back the rubber holder ① .
3. Remove:
 - Bulb holder ②
 - Turn the bulb holder counterclockwise.

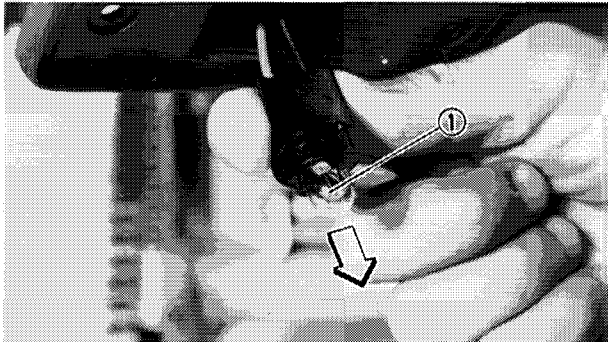

4. Pull out the defective bulb ① .

3

5. Install:
 - Taillight bulb (New)
 - Components above list (Steps "3, 2 and 1")



ENGINE OVERHAUL

ENGINE REMOVAL

NOTE:

It is not necessary to remove the engine in order to remove the following parts.

- Cylinder/Cylinder head
- Piston/Piston rings
- Primary drive gear
- Kick axle
- Shift shaft
- Flywheel magneto assembly
- Clutch

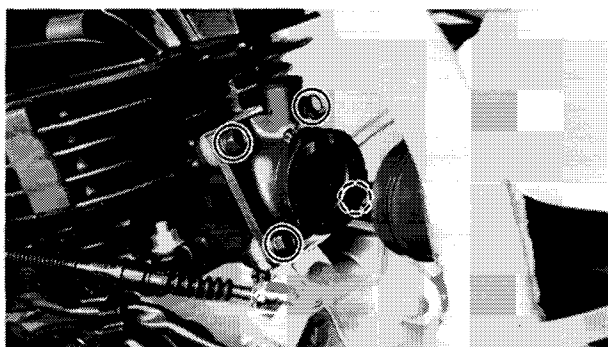
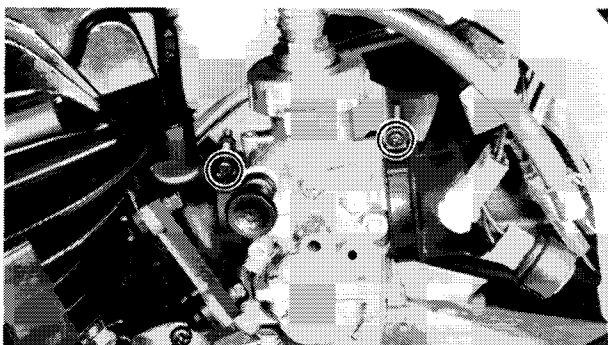
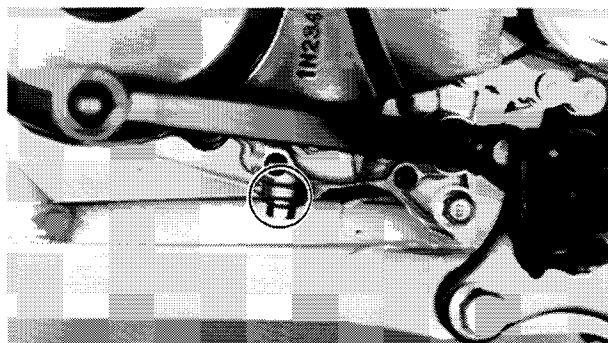

TRANSMISSION OIL

1. Drain:

- Transmission oil

Refer to "TRANSMISSION OIL REPLACEMENT" section in CHAPTER 3.

CARBURETOR

1. Remove:

- Carburetor

Refer to "CARBURETOR – REMOVAL" section in CHAPTER 5.

NOTE:

Cover the carburetor with a clean rag to prevent dirt or foreign matter into the carburetor.

REED VALVE

1. Remove:

- Carburetor joint
- Reed valve

Refer to "REED VALVE – REMOVAL" section in CHAPTER 5.

SEAT AND FUEL TANK

1. Remove:

- Seat ①

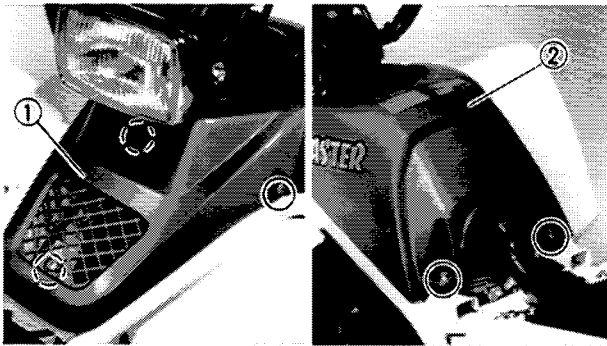

2. Remove:

- Fuel tank cover ① (Front)
- Fuel tank cover ② (Rear)
- Fuel tank cover (Inner)

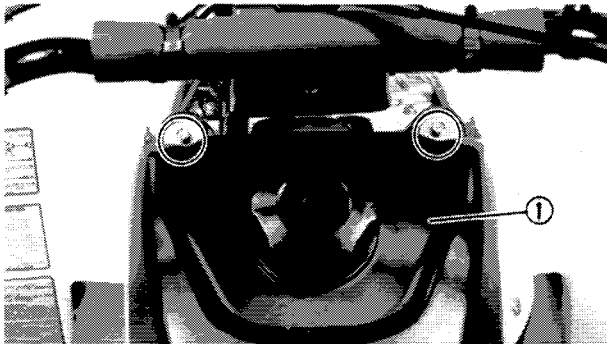

3. Remove:

- Fuel tank ①

4

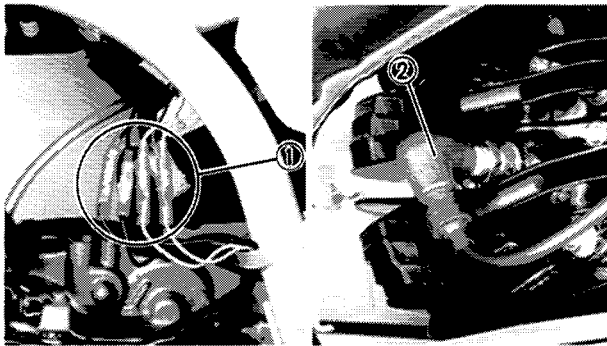

LEAD

1. Disconnect:

- C.D.I. magneto leads ①
- Spark plug lead ②

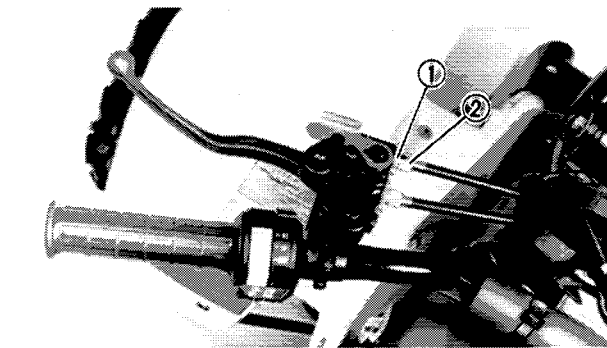

CABLE

1. Disconnect:

- Clutch cable
From clutch lever.

Removal step:

- Loosen the lock nut ① .
- Turn in the adjuster ② .
- Grip the lever and pull the cable out as you release the lever.

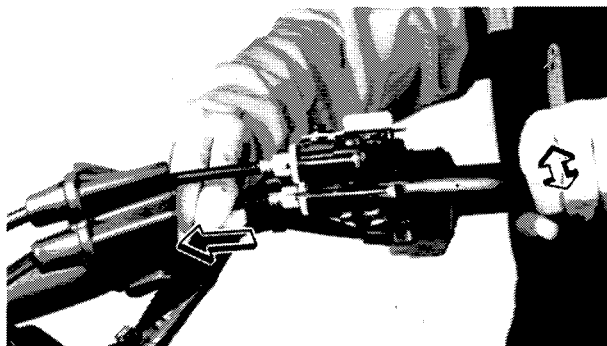

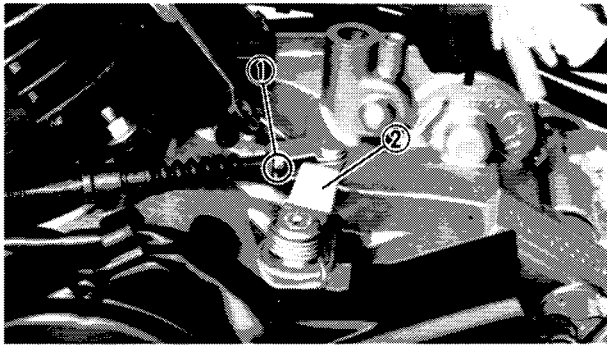

2. Disconnect:

- Cable end ① (Clutch cable)
- From push lever ② .

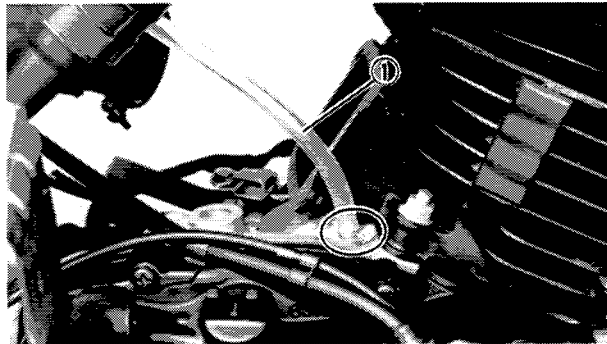

HOSE

1. Disconnect:

- Ventilation hose ①

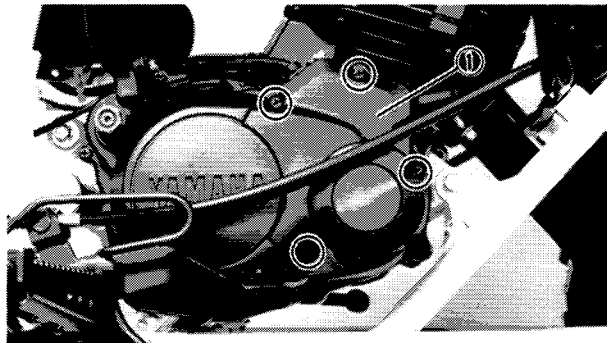

2. Remove:

- Cover ① (Autolube pump)

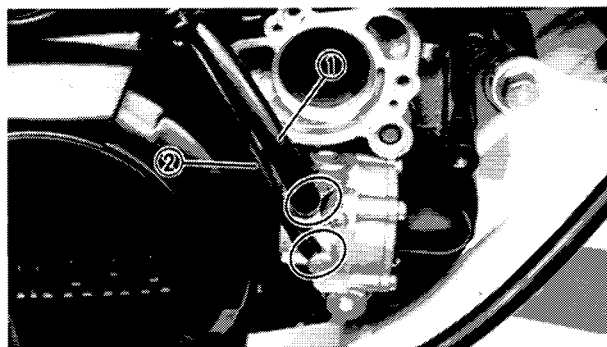

3. Disconnect:

- Oil hose ①
- Oil delivery hose ②

NOTE:

Plug the oil pipe so the oil will not run out of the oil tank.

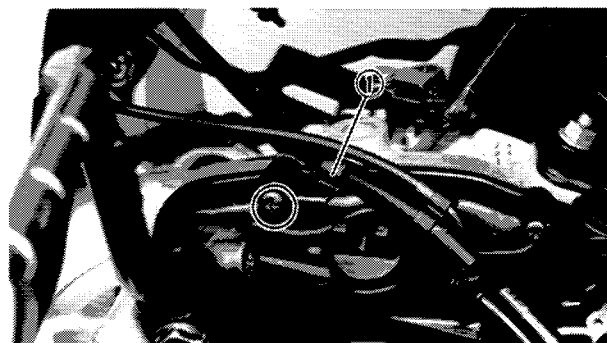

4. Remove:

- Clamp (Oil hose) ①

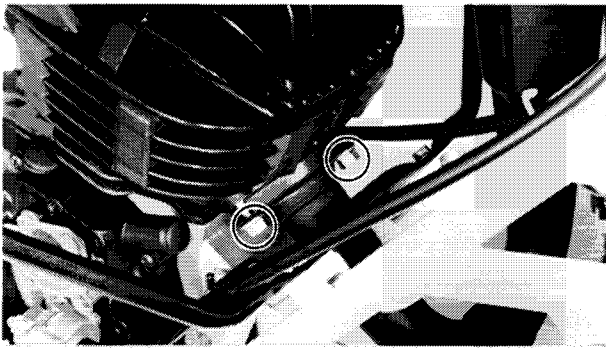
**EXHAUST PIPE**

1. Remove:
 - Exhaust pipe

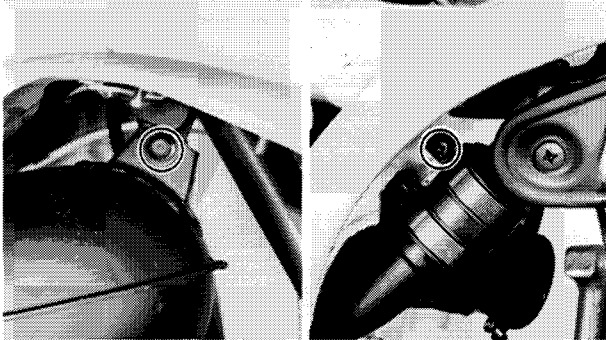
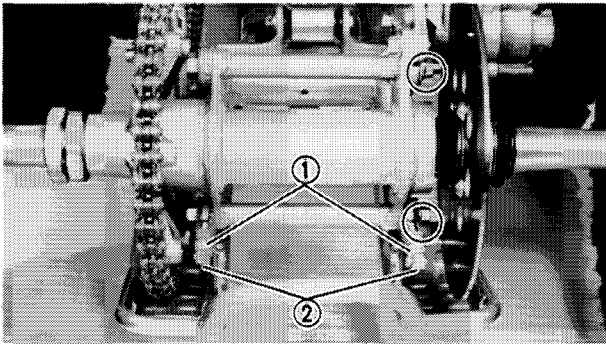
**4****DRIVE CHAIN**

1. Loosen:
 - Bolts (Rear axle hub)
 - Look nuts ①
 - Adjusters ②

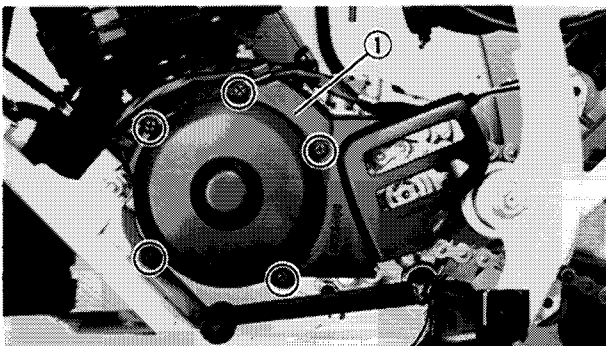

2. Remove:
 - Crankcase cover ① (Left)

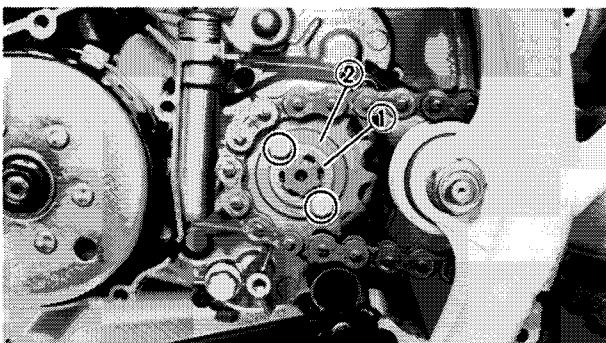

3. Remove:
 - Sprocket holder ①
 - Drive sprocket ②

NOTE:

Before removing the drive sprocket, increase the drive chain slack.

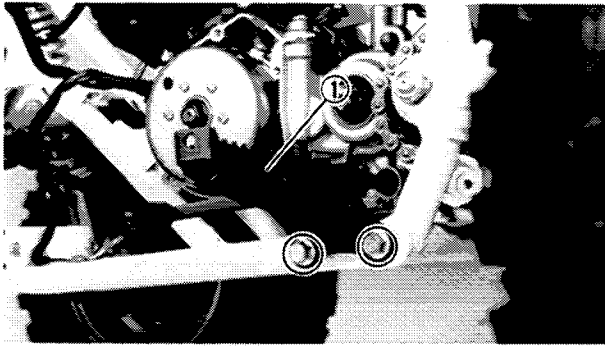
**FOOTREST**

1. Remove:
 - Footrest ① (Left)

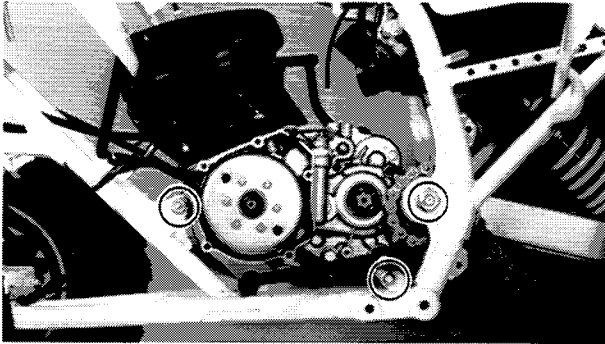
**ENGINE REMOVAL**

1. Remove:
 - Mounting bolts

NOTE: _____

The engine and swingarm are installed using the same pivot shaft. Therefore, take care so that the pivot shaft is pulled, not entirely out, but for enough to set the engine free.

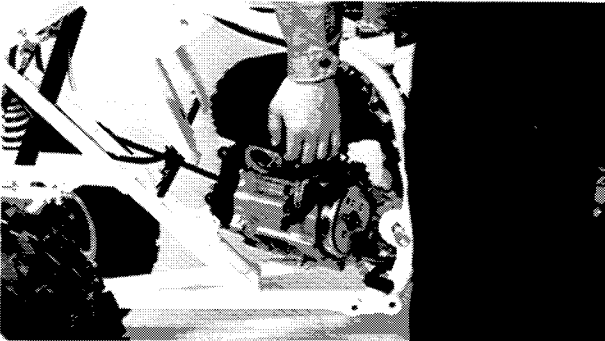

2. Remove:
 - Engine assembly
To the left.

4**ENGINE DISASSEMBLY****CYLINDER HEAD, CYLINDER AND PISTON****NOTE:** _____

With the engine mounted, the cylinder head, cylinder and piston can be maintained by removing the following parts.

- Exhaust pipe
 - Carburetor
 - Reed valve
-

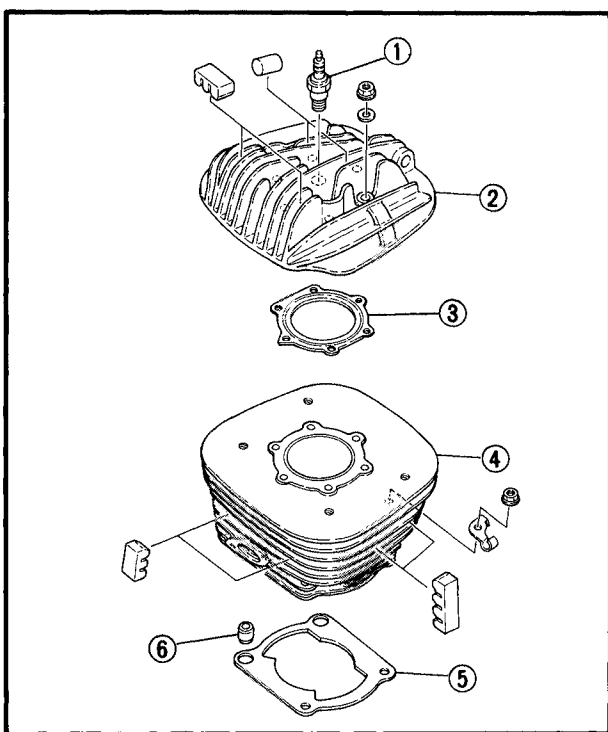

1. Remove:

- Spark plug ①
- Cylinder head ②
- Gasket ③ (Cylinder head)
- Cylinder ④
- Gasket ⑤ (Cylinder)
- Dowel pins ⑥

NOTE: _____

Loosen the nuts (Cylinder head) 1/2 turn each time, and remove.

4

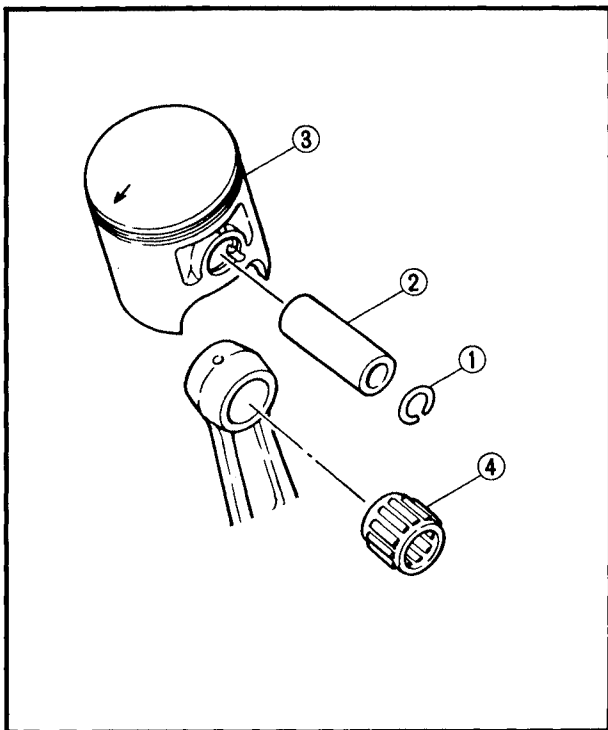

2. Remove:

- Piston pin clip ①
- Piston pin ②
- Piston ③
- Bearing ④

NOTE: _____

- Before removing the piston pin clip, cover the crankcase with a clean rag so you will not accidentally drop the clip into the crankcase.
- Before removing the piston pin, deburr the clip groove and pin hole area. If the piston pin groove is deburred and piston pin is still difficult to remove, use Piston Pin Puller.



Piston Pin Puller:
 P/N YU-01304
 P/N 90890-01304

CAUTION: _____

Do not use a hammer to drive the piston pin out.



CLUTCH

NOTE:

With the engine mounted, the clutch can be maintained by removing the following parts.

- Footrest (Right)

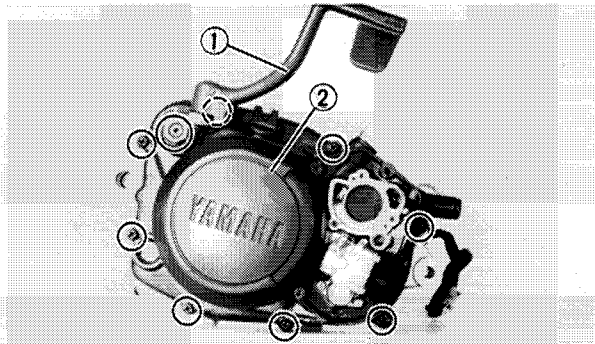

1. Remove:

- Kick crank ①
- Crankcase cover ② (Right)
- Gasket
- Dowel pins

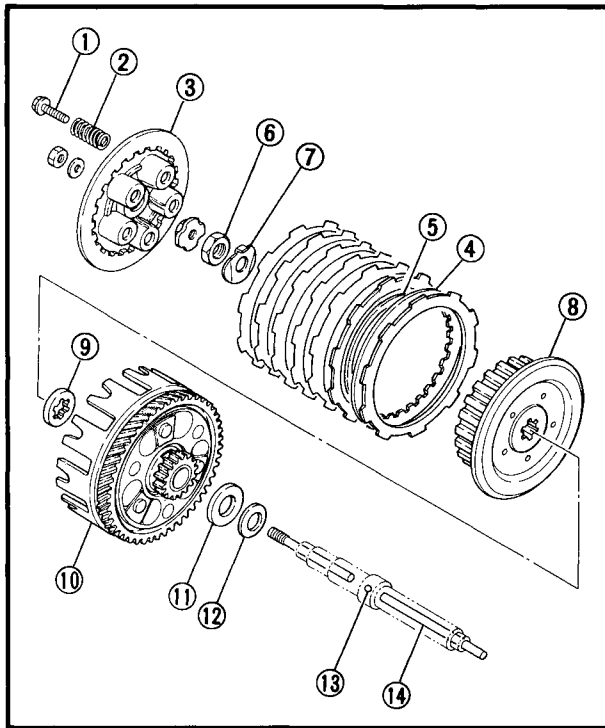

2. Remove:

- Bolts ①
- Clutch springs ②
- Pressure plate ③
- Friction plates ④
- Clutch plates ⑤
- Nut ⑥ (Clutch boss)
- Lock washer ⑦
- Clutch boss ⑧
- Spacer ⑨
- Clutch housing ⑩
- Spacer ⑪
- Conical spring washer ⑫
- Ball ⑬
- Push rod ⑭

NOTE:

- Before removing the nut (Clutch boss), straighten the lock washer tab.
- Hold the clutch boss by the Universal Clutch Holder ① to loosen the nut ② (Clutch boss).

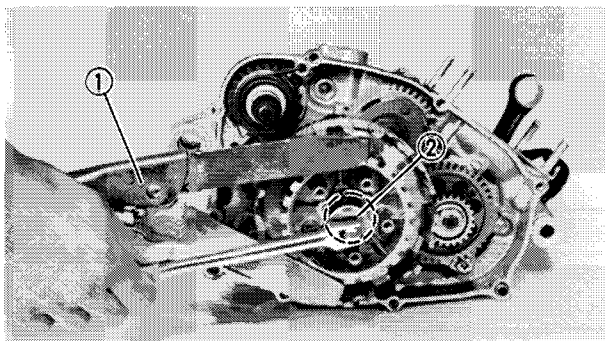

Universal Clutch Holder:
P/N YM-91042
P/N 90890-04086

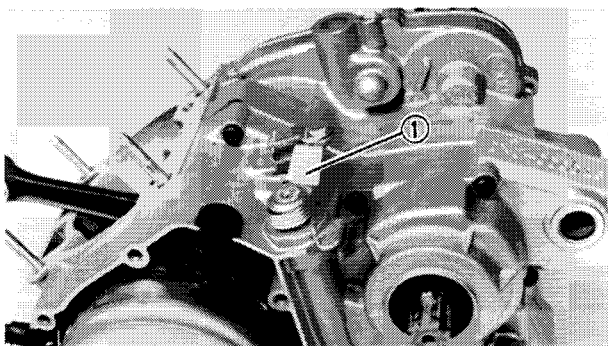

3. Remove:
- Push lever ①

PRIMARY DRIVE GEAR AND BALANCER GEAR

NOTE: _____

With the engine mounted, the primary drive gear and balancer gear can be maintained by removing the following parts.

- Footrest (Right)
- Kick crank
- Crankcase cover (Right)
- Clutch

4

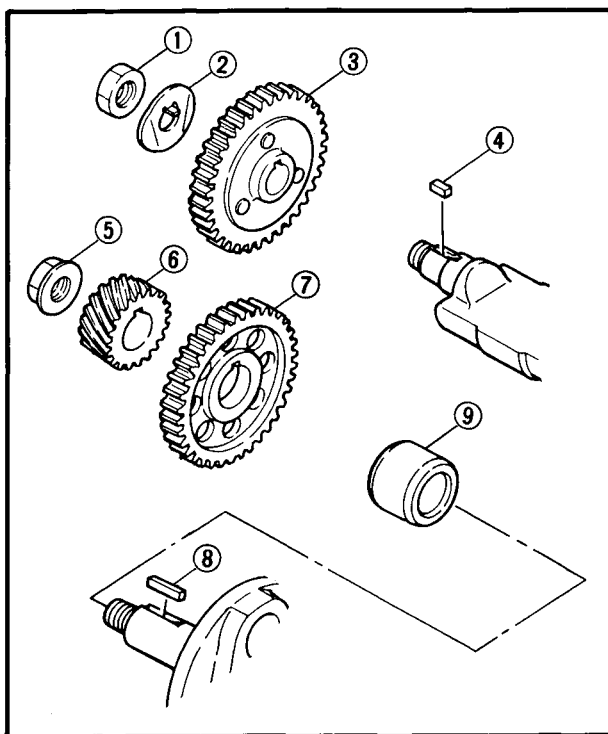

1. Remove:
- Nut ① (Balancer gear)
 - Lock washer ②
 - Balancer gear ③
 - Key ④
 - Nut ⑤ (Primary drive gear)
 - Primary drive gear ⑥
 - Balancer drive gear ⑦
 - Key ⑧
 - Collar ⑨

NOTE: _____

- Before removing the nut (Balancer gear), straighten the lock washer tab.
- Loosen both nuts simultaneously (Primary drive gear and balancer gear).

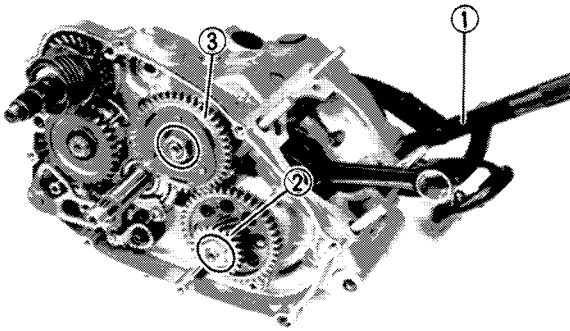

- Hold the rotor (CDI magneto) by the Rotor Holder ① to loosen the nuts (Primary drive gear ② and balancer gear ③).



Rotor Holder:
P/N YU-01235
P/N 90890-01235

KICK AXLE

NOTE:

With the engine mounted, the kick axle can be maintained by removing the following parts.

- Footrest (Right)
- Kick crank
- Crankcase cover (Right)
- Clutch

1. Unhook the kick spring from its position.
2. Remove:

- Kick axle assembly ①
Rotate the shaft counterclockwise.

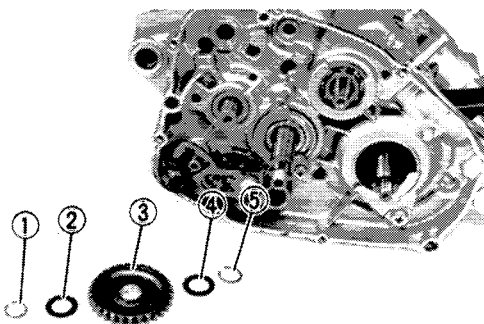
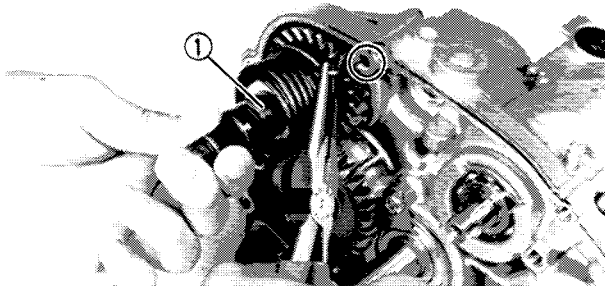

3. Remove:

- Circlip ①
- Plain washer ②
- Kick idle gear ③
- Plain washer ④
- Circlip ⑤

SHIFT SHAFT AND STOPPER LEVER

NOTE:

With the engine mounted, the shift shaft and stopper lever can be maintained by removing the following parts.

- Footrest (Right)
- Kick crank
- Crankcase cover (Right)
- Clutch

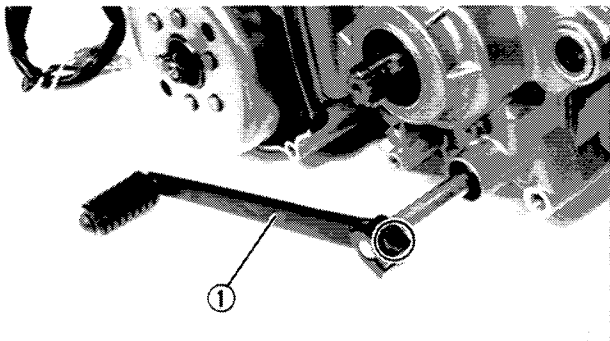

1. Remove:
 - Change pedal ①

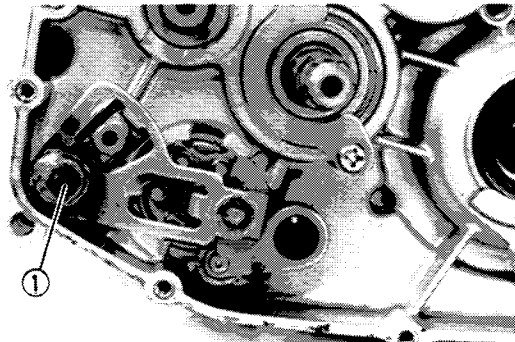

2. Remove:
 - Shift shaft ①
 - Spring

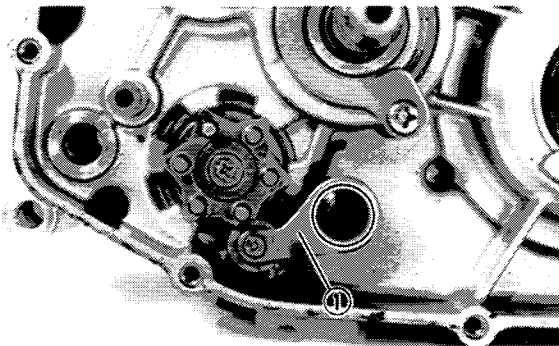

3. Remove:
 - Stopper lever ①
 - Spring

4

CDI MAGNETO

NOTE: _____

With the engine mounted, the CDI magneto can be maintained by removing the following parts.

- Crankcase cover (Left)

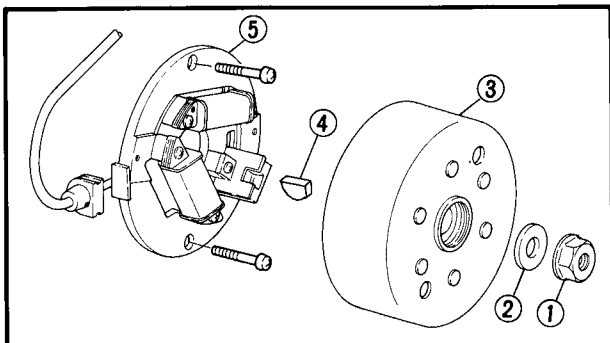

1. Remove:
 - Nut ①
 - Washer ②
 - Rotor ③
 - Key ④
 - Stator assembly ⑤

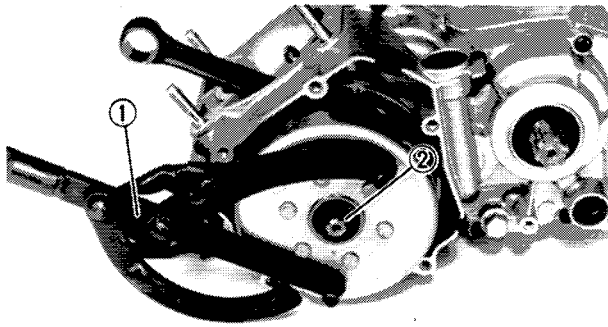
**NOTE:**

- Hold the rotor by the Rotor Holder ① to loosen the nut ② .
- Remove the rotor by the Rotor Puller ③ .



Rotor Holder:
P/N YU-01235
P/N 90890-01235

Rotor Puller:
P/N YM-01189
P/N 90890-01189

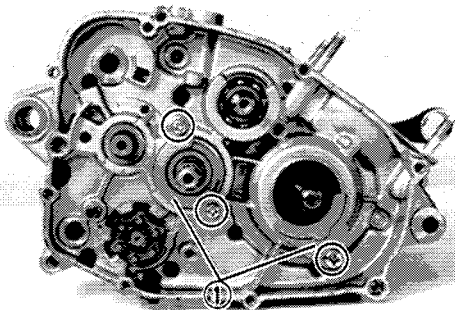
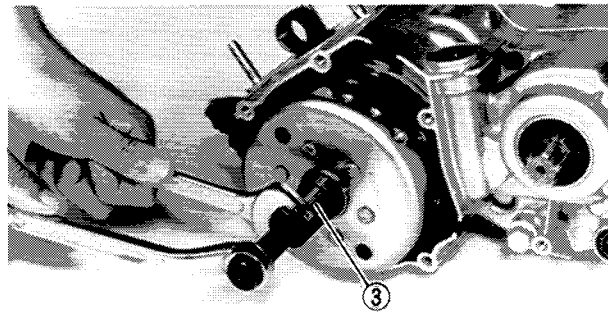
**CRANKCASE (RIGHT)****1. Remove:**

- Bearing stoppers ① (Main axle and crankshaft)

2. Remove:

- Bolts (Crankcase)

NOTE:

Loosen each screw 1/4 turn, and remove them after all are loosened.

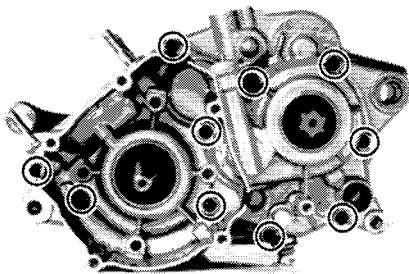
**3. Remove:**

- Crankcase (Right)
- Dowel pins

Removal step:

- Turn the shift cam to the position shown in the figure so that it does not contact the crankcase.

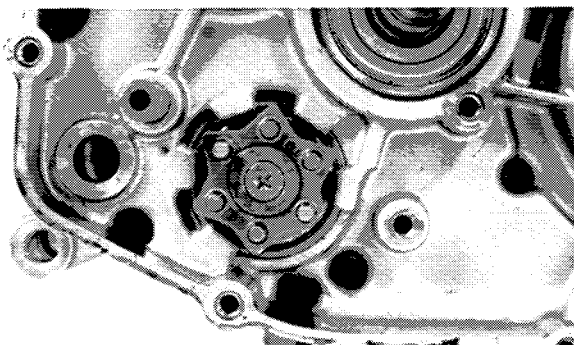
**4**

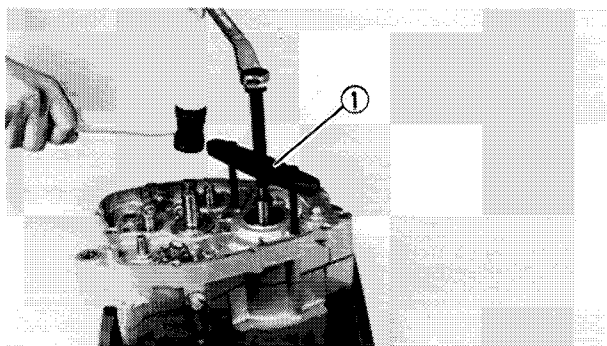

- Attach the Crankcase Separating Tool ① .



Crankcase Separating Tool:
P/N YU-01135
P/N 90890-01135

NOTE: _____
Fully tighten the tool holding bolts, but make sure the tool body is parallel with the case. If necessary, one screw may be backed out slightly to level tool body.

- As pressure is applied, alternately tap on the front engine mounting boss, transmission shafts, and shift cam.

⚠ CAUTION: _____

Use soft hammer to tap on the case half. Tap only on reinforced portions of case. Do not tap on gasket mating surface. Work slowly and carefully. Make sure the case halves separate evenly. If one end "hangs up", take pressure off the push screw, realign, and start over. If the cases do not separate, check for a remaining case screw or fitting. Do not force.

4

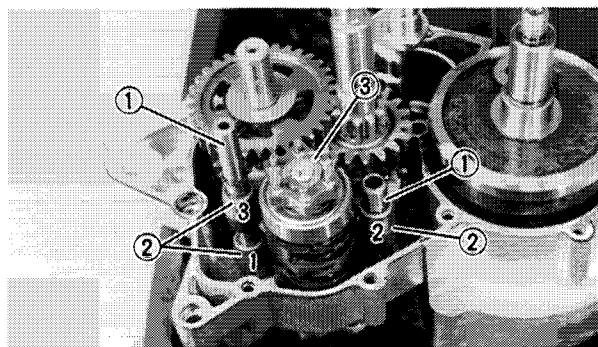

SHIFTER, TRANSMISSION AND BALANCER

1. Remove:

- Guide bars ①
- Shift forks ②
- Shift cam ③

NOTE: _____
Note the position of each part. Pay particular attention to the location and direction of shift forks.

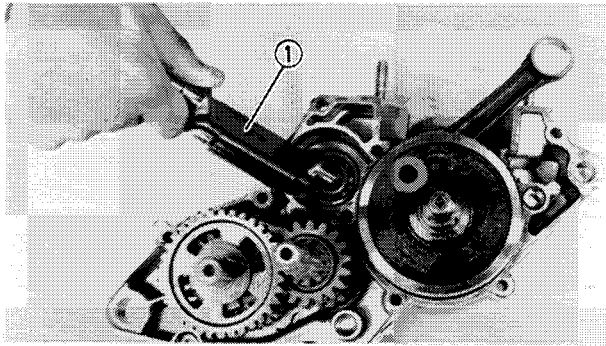

2. Remove:
- Balancer weight ①

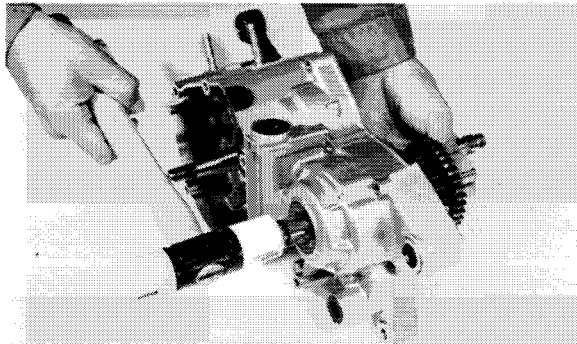

3. Remove:
- Transmission assembly
Tap lightly on the transmission drive shaft with a soft hammer.

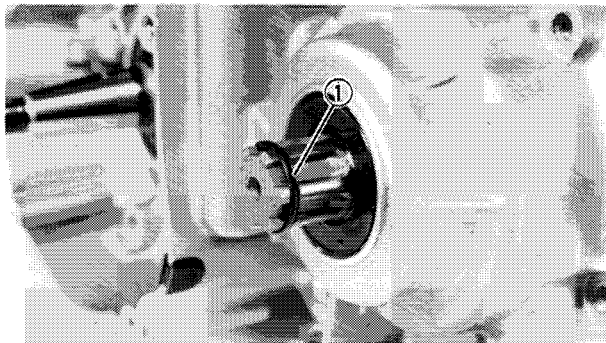

NOTE: _____

While removing the drive axle from the crankcase, pay careful attention to the oil seal lip. A recommended practice is to fit the O-ring ① and to apply grease over the fitted area.

4

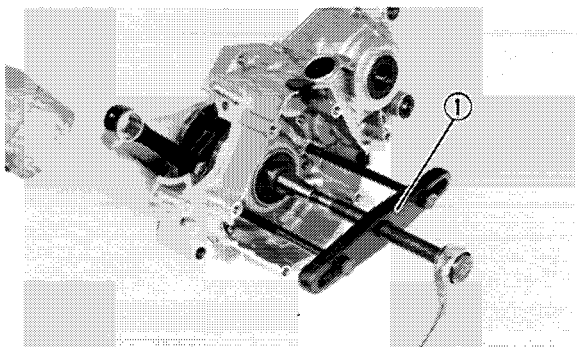

CRANKSHAFT

1. Remove:
- Crankshaft

NOTE: _____

- Attach the Crankcase Separating Tool ① to remove the crankshaft.



Crankcase Separating Tool:
P/N YU-01135
P/N 90890-01135

- Fully tighten the tool holding bolts, but make sure the tool body is parallel with the case. If necessary, one screw may be backed out slightly to level tool body.
- _____

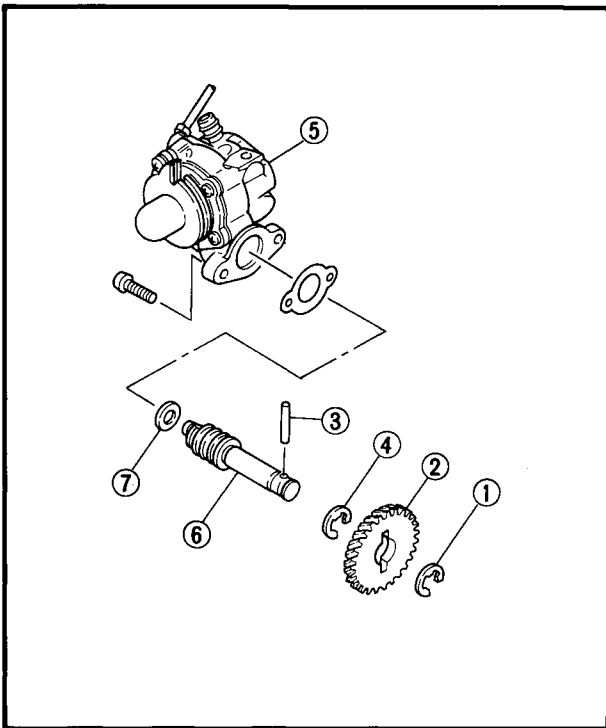

AUTOLUBE PUMP

1. Remove:

- Circlip ①
- Autolube pump gear ②
- Pin ③
- Circlip ④
- Autolube pump ⑤
- Drive shaft ⑥ (Autolube pump)
- Washer ⑦

4

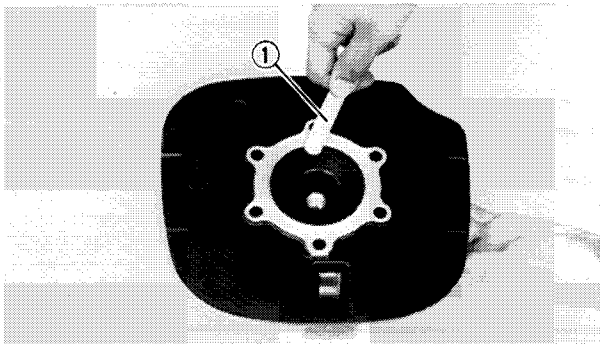

INSPECTION AND REPAIR

CYLINDER HEAD

1. Eliminate:

- Carbon deposits
- Use a rounded scraper ① .

NOTE:

Take care to avoid damaging the spark plug threads. Do not use a sharp instrument. Avoid scratching the aluminum.

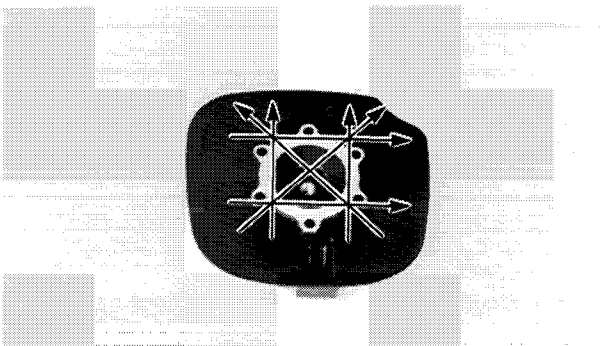

2. Measure:

- Cylinder head warpage
- Out of specification → Resurface.



Warpage Limit:
0.03 mm (0.0012 in)

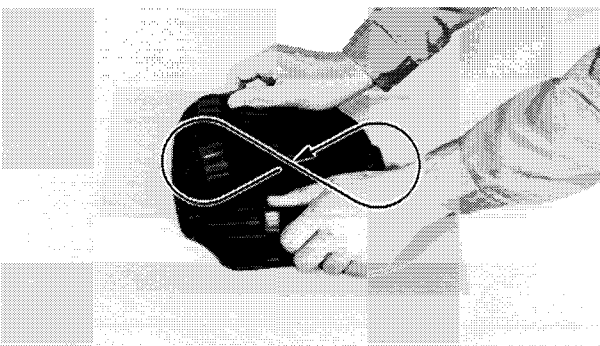

Warpage measurement and resurfacement steps:

- Attach a straight edge and a thickness gauge on the cylinder head.
- Measure the warpage.
- If the warpage is out of specification, resurface the cylinder head.



- Place a 400 ~ 600 grit wet sandpaper on the surface plate, and resurface the head using a figure-eight sanding pattern.

NOTE: _____

Rotate the head several times to avoid removing too much material from one side.

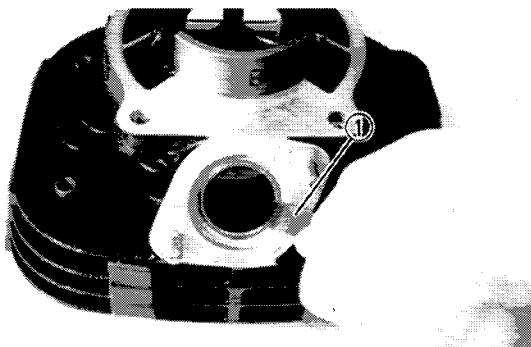
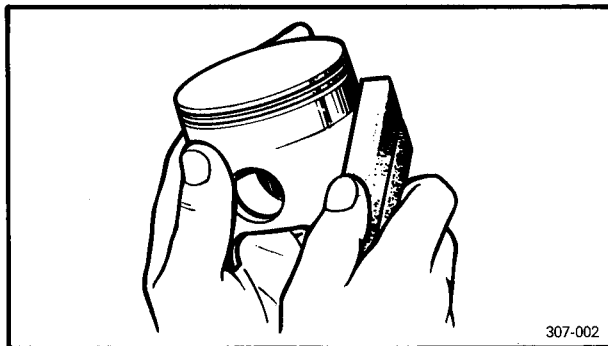
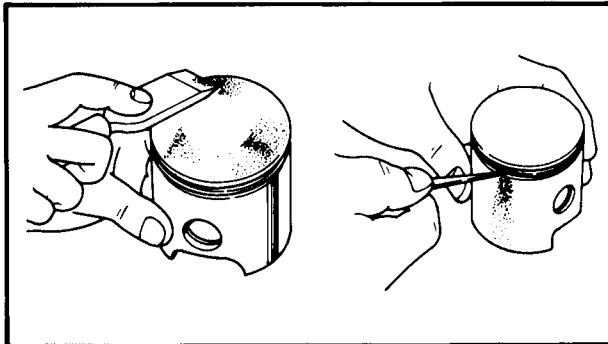

CYLINDER AND PISTON

1. Eliminate:
 - Carbon deposits
From the piston crown and ring grooves.
2. Eliminate:
 - Score marks and lacquer deposits
From the sides of piston.
Use a 600 ~ 800 grit wet sandpaper.

NOTE: _____

Sand in a crisscross pattern. Do not sand excessively.

3. Inspect:
 - Piston wall
Wear/Scratches/Damage → Replace.

4. Eliminate:
 - Carbon deposits
Use a rounded scraper ①.

5. Inspect:
 - Cylinder wall
Wear/Scratches → Rebore or replace.

4



6. Measure:
- Piston-to-cylinder clearance

Piston-to-cylinder clearance measurement steps:

First step:

- Measure the cylinder bore "C" with a Cylinder Bore Gauge.

NOTE:

Measure the cylinder bore "C" in parallel to and at right angles to the crankshaft. Then, find the average of the measurements.

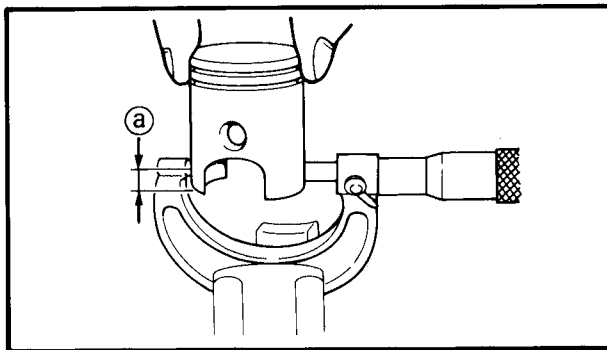
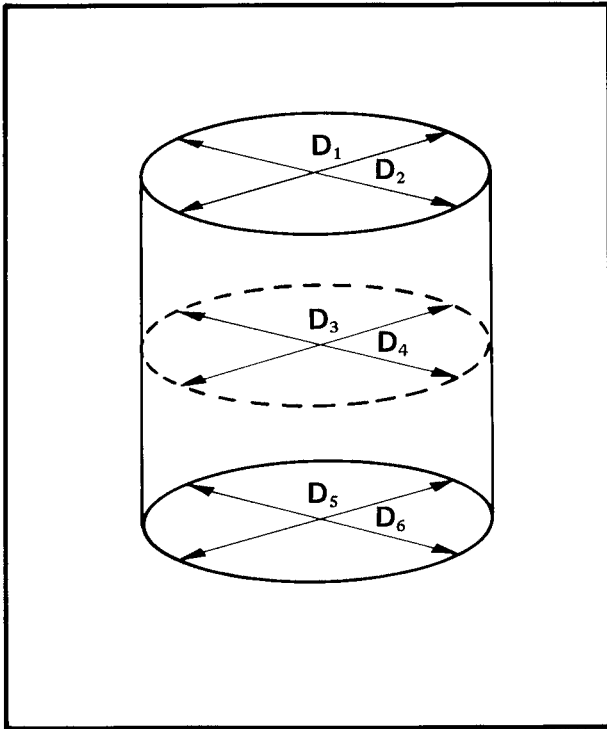

	Standard	Wear Limit
Cylinder Bore "C"	66.00 ~ 66.02 mm (2.598 ~ 2.599 in)	66.1 mm (2.602 in)
Taper "T"	—	0.08 mm (0.003 in)
Out of Round "R"	—	0.05 mm (0.002 in)

C = Maximum D
 T = (Maximum D₁ or D₂) – (Minimum D₅ or D₆)
 R = (Maximum D₁, D₃ or D₅) – (Minimum D₂, D₄ or D₆)

- If out of specification, rebore or replace cylinder, and replace piston and piston rings as a set.

2nd step:

- Measure the piston skirt diameter "P" with a micrometer.

Ⓐ 10.0 mm (0.39 in) from the piston bottom edge.

	Piston Size P
Standard	65.965 ~ 66.000 mm (2.597 ~ 2.598 in)
Oversize 1	66.25 mm (2.608 in)
Oversize 2	66.50 mm (2.618 in)

- If out of specification, replace piston and piston rings as a set.

4



3rd step:

- Calculate the piston-to-cylinder clearance with following formula:

$$\text{Piston-to-cylinder Clearance} = \text{Cylinder Bore "C"} - \text{Piston Skirt Diameter "P"}$$

- If out of specification, rebore or replace cylinder, and replace piston and piston rings as a set.



Piston-to-cylinder Clearance:
 0.035 ~ 0.040 mm
 (0.0014 ~ 0.0016 in)
 Limit: 0.1 mm (0.004 in)

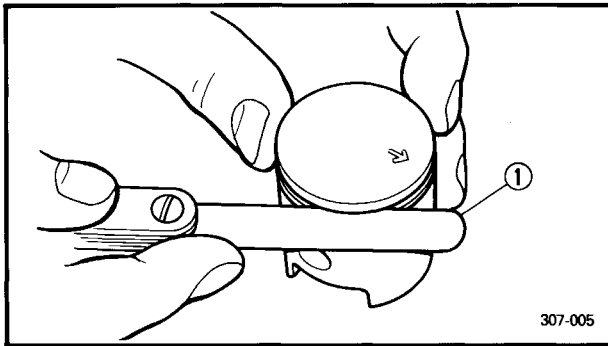

307-005

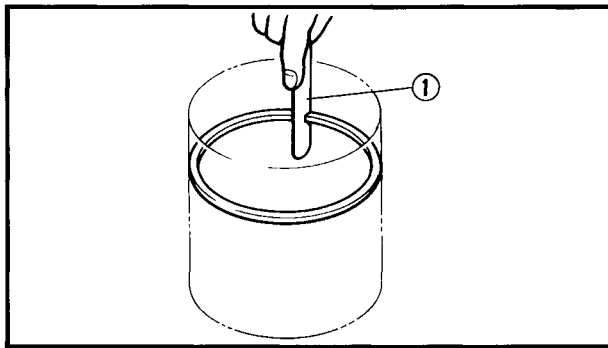

PISTON RINGS

1. Measure:

- Side clearance
 Out of specification → Replace piston and/or rings.
 Use a Feeler Gauge ① .

Side Clearance	Top	0.03 ~ 0.05 mm (0.0012 ~ 0.0020 in)
	2nd	0.03 ~ 0.05 mm (0.0012 ~ 0.0020 in)

2. Install:

- Piston ring
 (Into the cylinder)
 Push the ring with the piston crown.

3. Measure:

- End gap
 Out of specification → Replace rings as a set.
 Use a Feeler Gauge ① .

End Gap	Top	0.20 ~ 0.35 mm (0.008 ~ 0.014 in)
	2nd	0.20 ~ 0.35 mm (0.008 ~ 0.014 in)



PISTON PIN AND BEARING

1. Lubricate:
 - 2 cycle oil (Lightly)
(To the piston pin and bearing)
2. Install:
 - Small end bearing
 - Piston pin
(Into the small end of connecting rod)

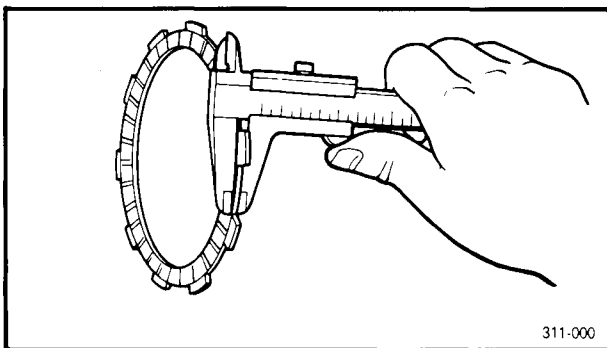
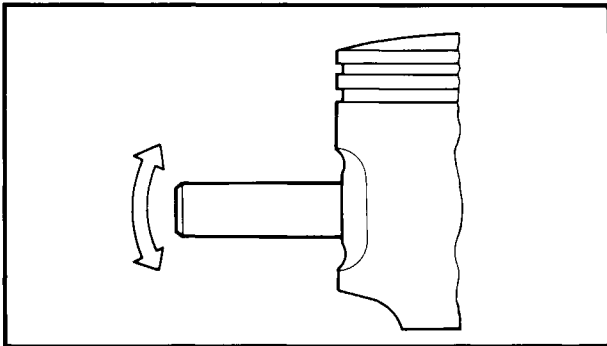
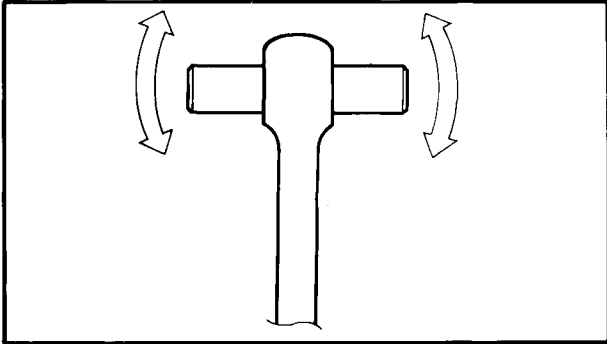

311-000

3. Check:
 - Free play
There should be no noticeable for the play.
Free play exists → Inspect the connecting rod for wear/Replace the pin and/or connecting rod as required.
4. Install:
 - Piston pin
(Into the piston pin hole).
5. Check:
 - Free play (When the piston pin is in place in the piston)
There should be no noticeable for the play.
Free play exists → Replace piston pin and/or piston.
6. Inspect:
 - Piston pin and bearing
Signs of heat discoloration → Replace.

CLUTCH

1. Inspect:
 - Friction plate
Damage/Wear → Replace friction plate as a set.
2. Measure:
 - Friction plate thickness
Out of specification → Replace friction plate as a set.
Measure at all four point.



Wear Limit: 2.8 mm (0.11 in)

4

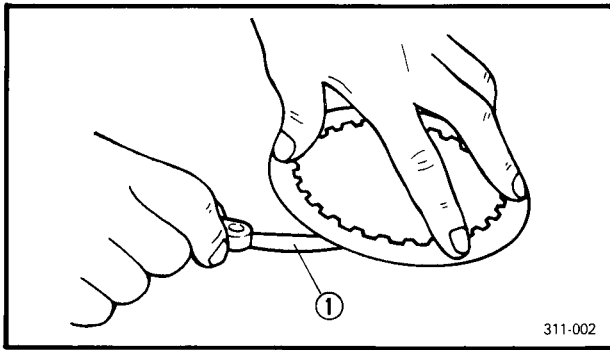

3. Inspect:

- Clutch plate
Damage → Replace clutch plate as a set.

4. Measure:

- Clutch plate warpage
Out of specification → Replace clutch plate as a set.
Use a surface plate and Feeler Gauge ① .



Warp Limit: 0.05 mm (0.002 in)

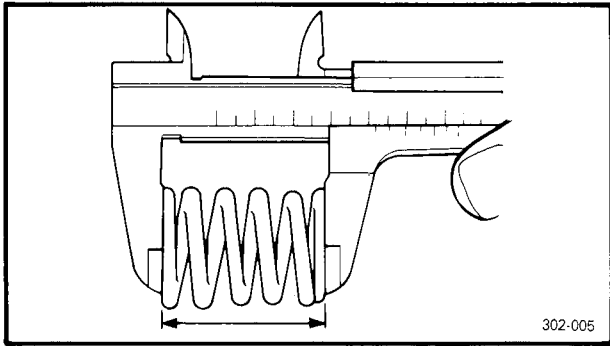

5. Measure:

- Clutch spring free length
Out of specification → Replace spring as a set.



Clutch Spring Minimum Length: 30.0 mm (1.18 in)

4

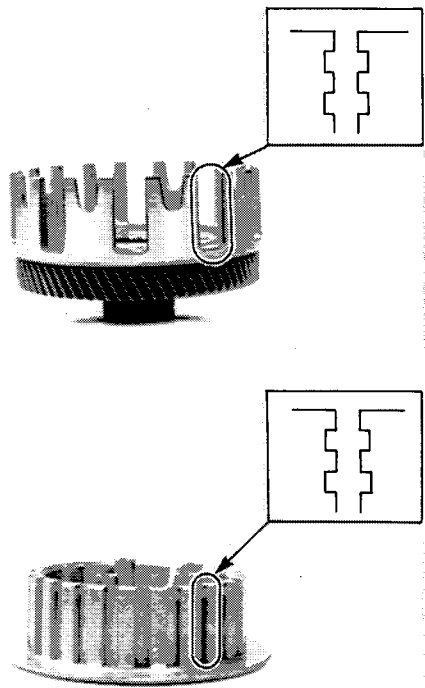

6. Inspect:

- Dogs on the clutch housing
Cracks/Wear/Damage → Deburr or replace.
- Clutch housing bearing
Scoring/Wear/Damage → Replace clutch housing.

NOTE: _____
Scoring on the clutch housing dogs will cause erratic operation.

7. Inspect:

- Clutch boss splines
Scoring/Wear/Damage → Replace clutch boss.

NOTE: _____
Scoring on the clutch boss splines will cause erratic operation.

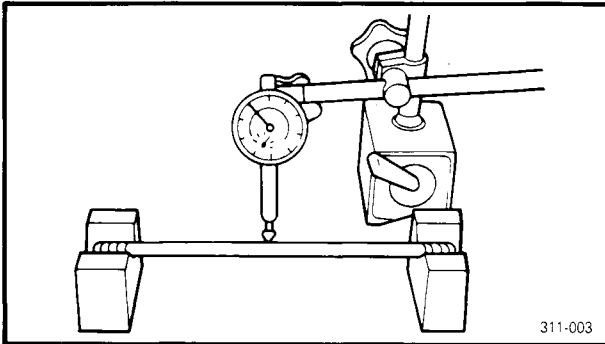
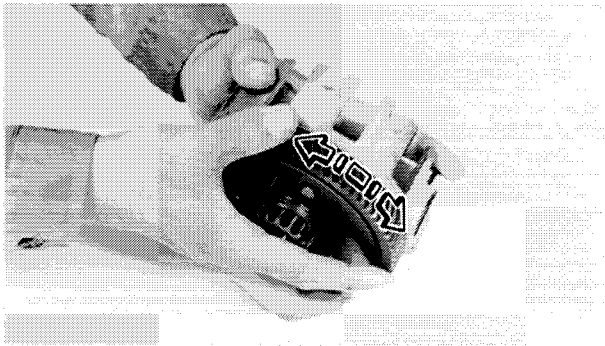

8. Check:

- Circumferential play
- Free play exists → Replace.

9. Measure:

- Push rod runout (Long rod)
- Out of specification → Replace.
- Use the V-Blocks and Dial Gauge.



Runout Limit:
0.30 mm (0.012 in)

10. Inspect:

- Push lever
- Wear/Damage → Repair using 300 ~ 400 grit sand paper or replace.

4

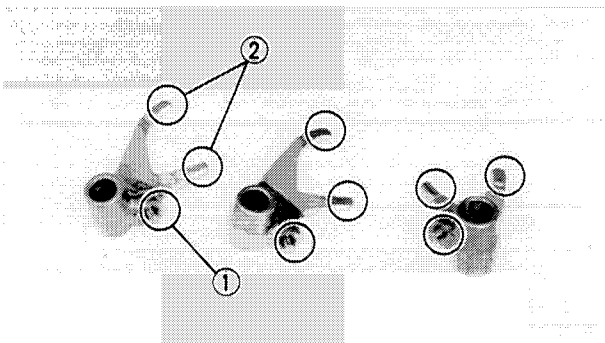
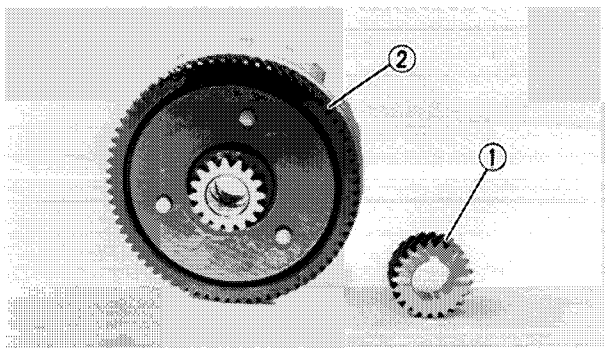
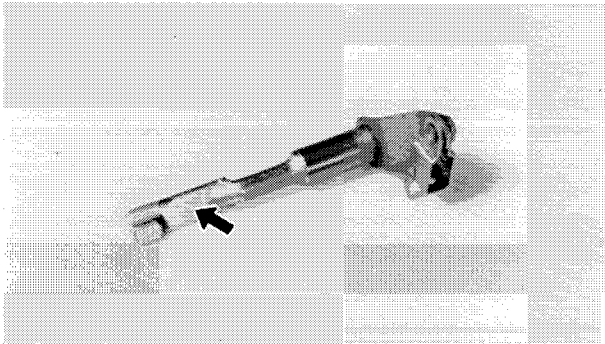
**PRIMARY DRIVE**

1. Inspect:

- Primary drive gear teeth ①
- Primary driven gear teeth ②
- Wear/Damage → Replace both gears.
- Excessive noises during operation → Replace both gears.

TRANSMISSION AND SHIFTER

1. Inspect:

- Shift fork cam follower ①
- Shift fork pawl ②
- Scoring/Bends/Wear → Replace.

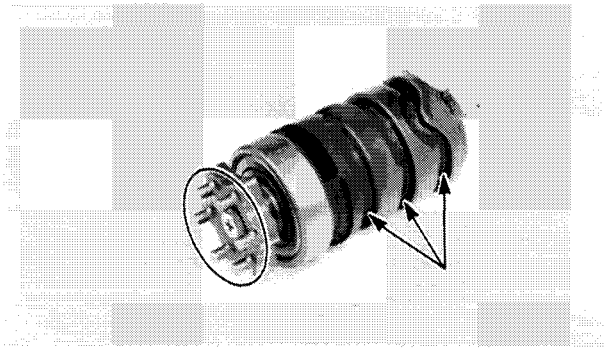

2. Inspect:

- Shift cam groove
 - Shift cam segment
- Wear/Damage → Replace.

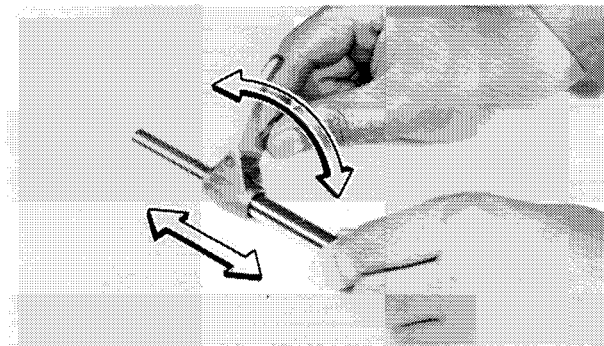

3. Check:

- Shift fork movement
- Unsmooth operation → Replace shift fork and/or guide bar.

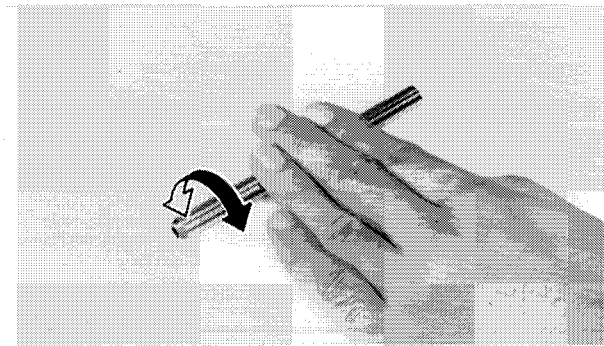

4. Inspect:

- Guide bar
- Roll the guide bar on a flat surface.
Bends → Replace.

4

WARNING:

Do not attempt to straighten a bent guide bar.

5. Measure:

- Axle runout
- Use centering device and dial gauge.
Out of specification → Replace bent axle.



Runout Limit:
0.08 mm (0.003 in)

6. Inspect:

- Gear teeth
- Blue discoloration/Pitting/Wear → Replace.
- Mated dogs
- Rounded edges/Cracks/Missing portions → Replace.



7. Check:

- Proper gear engagement (Each gear)
(To its counter part)
Incorrect → Reassemble.
- Gear movement
Roughness → Replace.

8. Inspect:

- Circlips
Damage/Looseness/Bends → Replace.

4

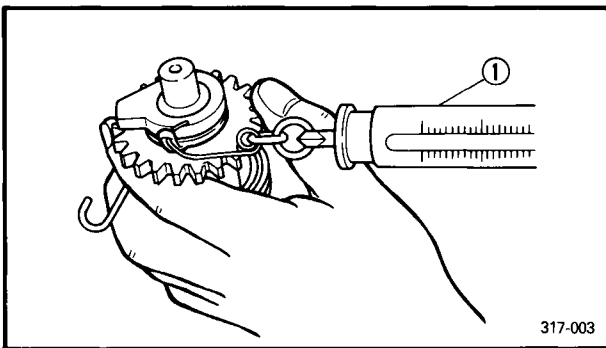
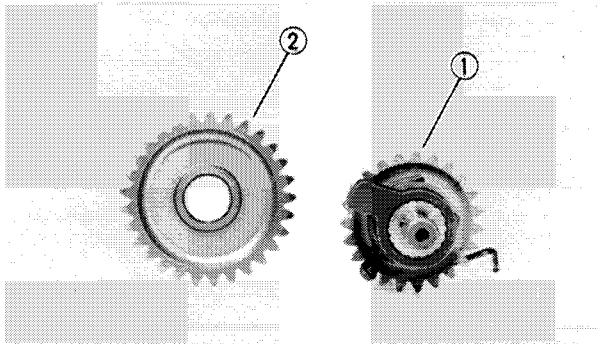

KICK STARTER

1. Inspect:

- Kick gear teeth ①
- Kick idle gear teeth ②
Damage/Wear → Replace both gears.

2. Measure:

- Kick clip tension
Out of specification → Replace.
Use a spring balance ①.

Kick Clip Tension:
0.8 ~ 1.2 kg (1.8 ~ 2.6 lb)

CAUTION:

Do not try to bend the clip.

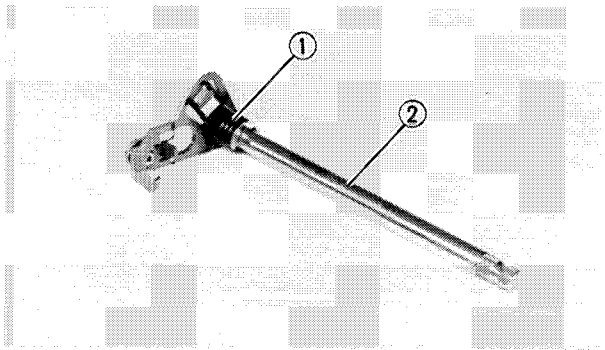
**SHIFT SHAFT**

1. Inspect:

- Spring ①
Damage → Replace.
- Shift shaft ②
Damage/Bends/Wear → Replace.

AUTOLUBE PUMP

Wear or an internal malfunction may cause pump output to vary from the factory setting. This situation is, however, extremely rare. If improper output is suspected, inspect the following:

1. Inspect:

- Delivery line
Obstructions → Blow out.
- Pump body seal/Crankcase cover seal
Wear/Damage → Replace.
- Check ball/Spring
Miss/Improper → Repair.

2. Inspect:

- Allowing air
Air exists → Air bleed.

3. Check:

- Pump output
Out of specification → Adjust.

Output at 200 Stroke:

**3.47 ~ 4.23 cm³ (0.122 ~ 0.149 Imp oz,
0.117 ~ 0.143 US oz)**

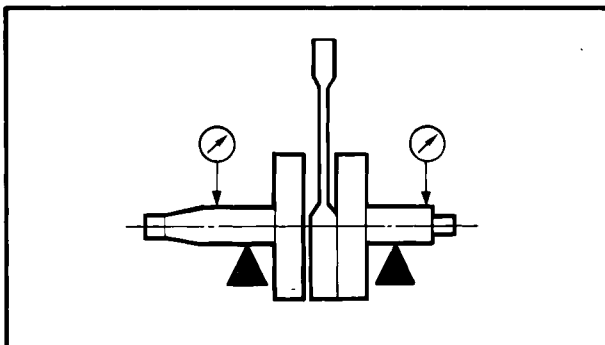
**CRANKSHAFT**

1. Measure:

- Runout
Use a centering device and Dial Gauge.
Out of specification → Replace or repair.

**Runout Limit:**

0.03 mm (0.0012 in)

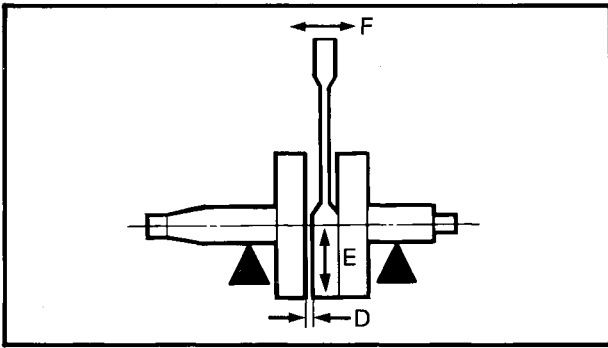

2. Measure:

- Small end free play "F"

Use a Dial Gauge.

Out of specification → Replace the defective parts.

**Small End Free Play:**

0.8 ~ 1.0 mm (0.031 ~ 0.039 in)

3. Measure:

- Big end side clearance "D"

Use a Feeler Gauge.

Out of specification → Replace the defective parts.

**Big End Side Clearance:**

0.4 ~ 0.7 mm (0.016 ~ 0.028 in)

4. Measure:

- Big end radial clearance "E"

Use a Dial Gauge.

Out of specification → Replace the defective parts.

**Big End Radial Clearance:**

0.021 ~ 0.035 mm
(0.0008 ~ 0.0014 in)

5. Inspect:

- Crankshaft bearing

Pitting/Damage → Replace.

NOTE:

Lubricate the bearing immediately after examining them to prevent rust.

6. Inspect:

- Oil seals

Wear/Damage → Replace.

**CRANKCASE**

1. Thoroughly wash the case halves in mild solvent.
2. Clean all the gasket mating surfaces and crankcase mating surfaces thoroughly.

3. Inspect:

- Crankcase
Cracks/Damage → Replace.
- Oil delivery passages
Clog → Blow out with compressed air.

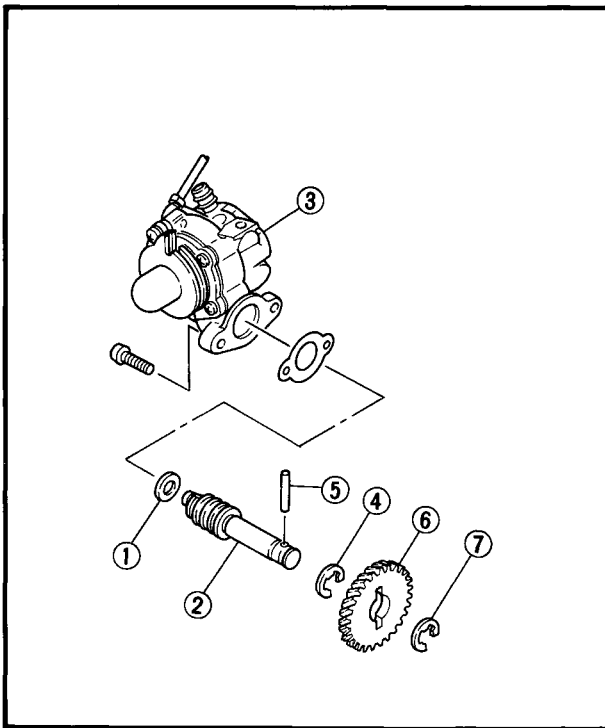

ENGINE ASSEMBLY AND ADJUSTMENT

AUTOLUBE PUMP

1. Install:

- Washer ①
- Drive shaft ② (Autolube pump)
- Autolube pump ③
- Circlip ④
- Pin ⑤
- Autolube pump gear ⑥
- Circlip ⑦

4

CARANKSHAFT

⚠ CAUTION:

To protect the crankshaft against scratches or to facilitate the operation of the installation. Apply the grease to the oil seal lips, and apply the engine oil to each hearing.

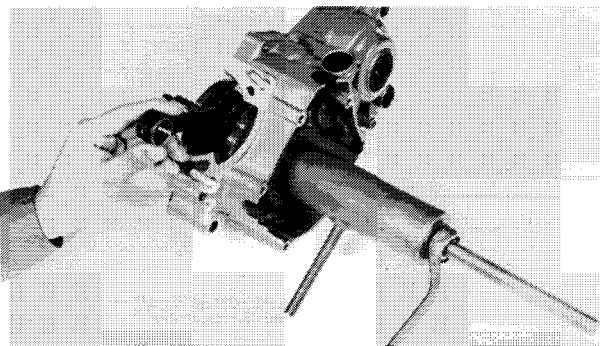

1. Install:

- Crankshaft

NOTE:

- Attach the Crankshaft Installing Tool to install the crankshaft.



Crankshaft Installing Tool:

P/N YU-90050
P/N YM-1383

P/N 90890-01274
P/N 90890-01275
P/N 90890-01278

- Hold the connecting rod at top dead center with one hand while turning the nut of the Installing Tool with the other. Operate the Installing Tool until the crankshaft bottoms against the bearing.



AUTOLUBE PUMP

- ① Autolube pump
- ② Gasket
- ③ Washer
- ④ Drive shaft
- ⑤ Pin
- ⑥ Oil seal
- ⑦ Circlip
- ⑧ Autolube pump gear

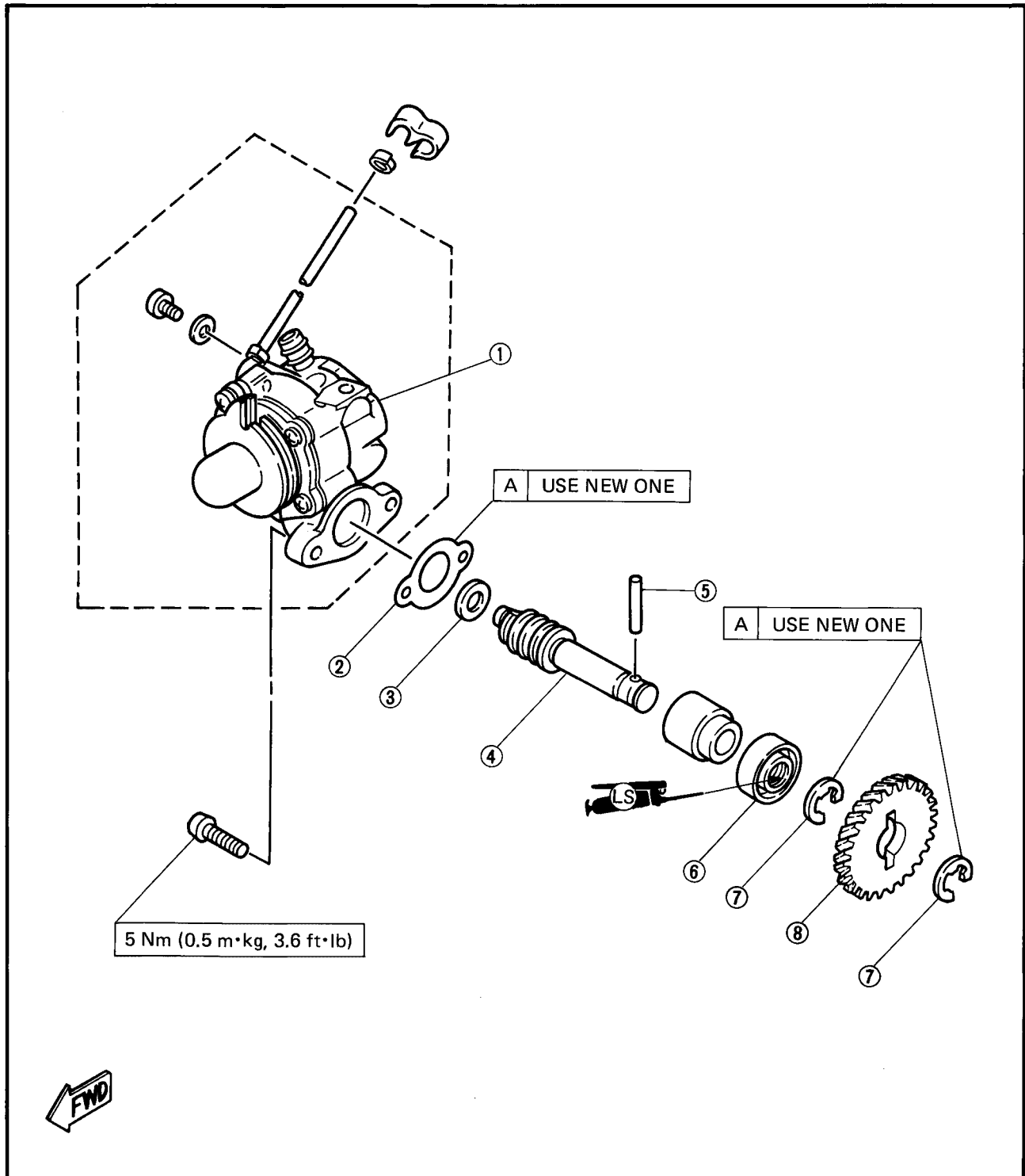



CRANKSHAFT, PISTON AND BALANCER

- ① Balancer gear
- ② Bearing
- ③ Key
- ④ Balancer
- ⑤ Bearing
- ⑥ Balancer drive gear
- ⑦ Oil seal
- ⑧ Collar
- ⑨ Bearing
- ⑩ Piston ring
- ⑪ Piston pin clip
- ⑫ Piston
- ⑬ Piston pin
- ⑭ Bearing
- ⑮ Key
- ⑯ Crank (Right)
- ⑰ Bush
- ⑱ Conecting rod
- ⑲ Crank pin
- ⑳ Bearing
- ㉑ Crank (Left)
- ㉒ Key
- ㉓ Bearing
- ㉔ Oil seal

A	PISTON-TO-CYLINDER CLEARANCE: 0.035 ~ 0.040 mm (0.0014 ~ 0.0016 in)
B	END GAP (INSTALLED): 0.20 ~ 0.35 mm (0.008 ~ 0.014 in)
C	SIDE CLEARANCE: 0.03 ~ 0.05 mm (0.0012 ~ 0.0020 in)

D	CRANKSHAFT:
A:	57.90 ~ 57.95 mm (2.280 ~ 2.281 in)
C:	0.03 mm (0.0012 in)
D:	0.4 ~ 0.7 mm (0.016 ~ 0.028 in)
E:	0.021 ~ 0.035 mm (0.0008 ~ 0.0014 in)
F:	0.8 ~ 1.0 mm (0.03 ~ 0.04 in)

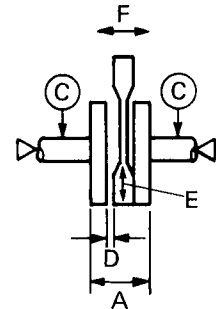

4

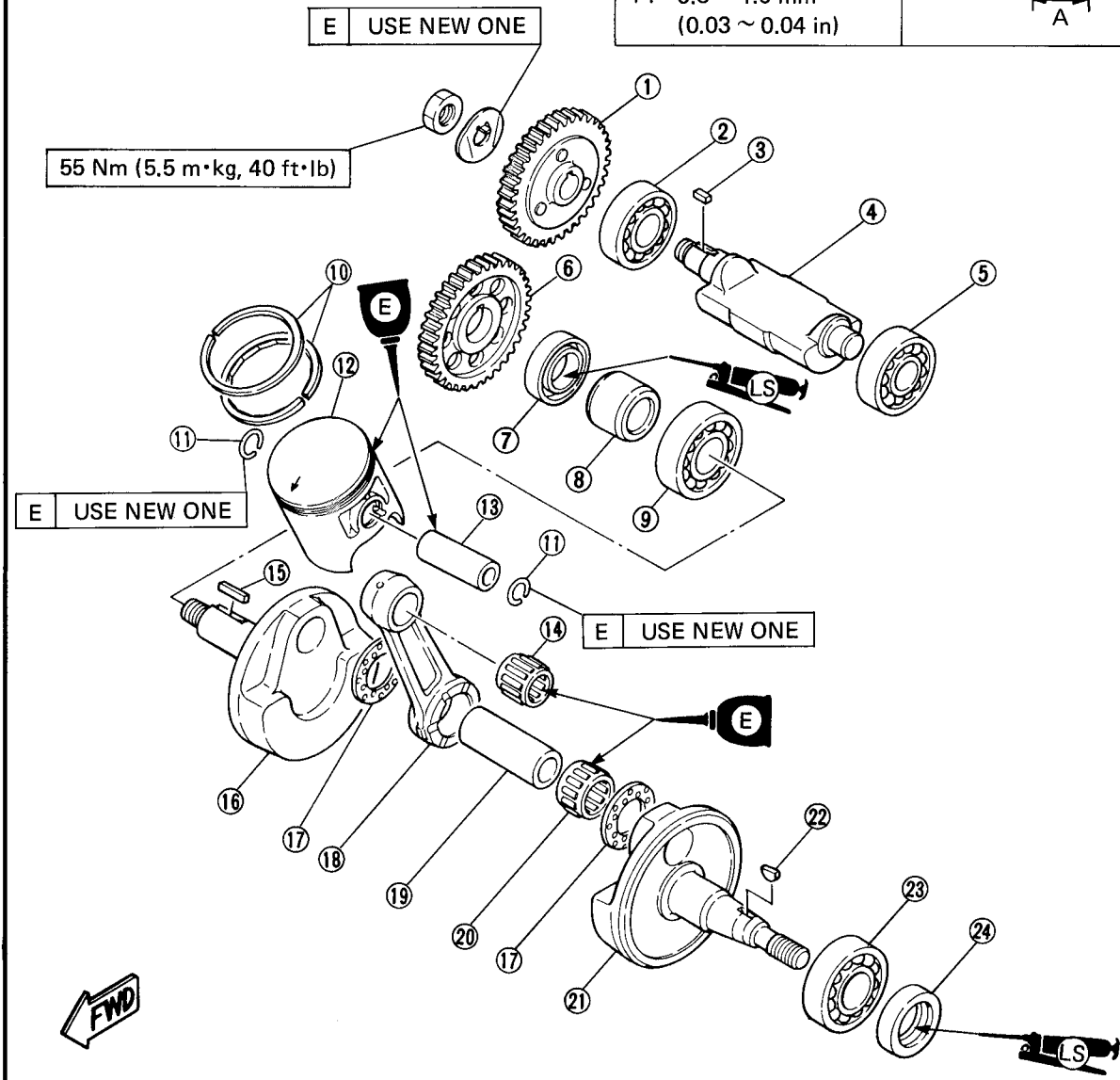

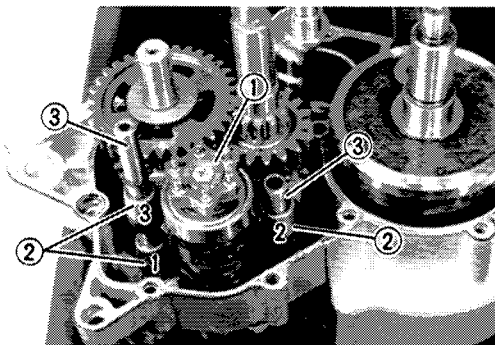
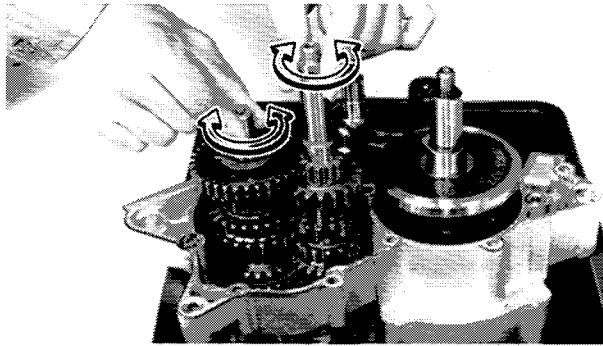
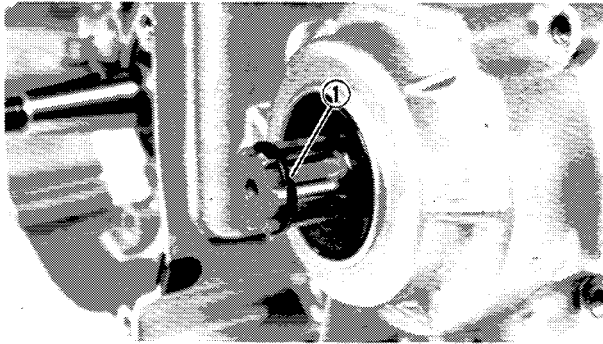
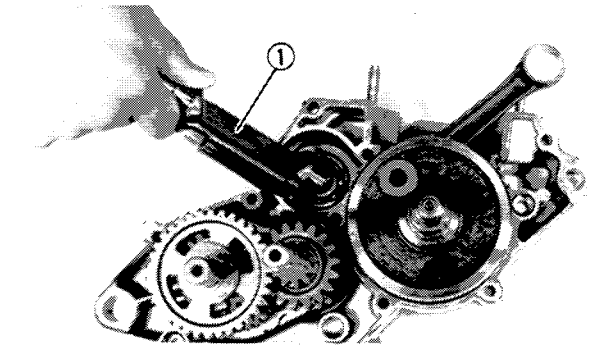

BALANCER, TRANSMISSION AND SHIFTER

1. Install:

- Balancer weight ①

2. Install:

- Transmission assembly

NOTE:

While installing the drive axle into the crankcase, pay careful attention to the oil seal lip.

A recommended practice is to fit the O-ring ① and apply grease over the fitted area.

3. Check:

- Transmission operation
Unsmooth operation → Repair.

4. Install:

- Shift cam ①
- Shift forks ②
- Guide bars ③

NOTE:

Each shift forks is identified by a number cast on its side. All the numbers should face the left side.

5. Check:

- Shifter operation
Unsmooth operation → Repair.



TRANSMISSION

- ① Drive axle
- ② Bearing
- ③ Oil seal
- ④ Drive sprocket
- ⑤ Sprocket
- ⑥ Bearing
- ⑦ Circlip
- ⑧ Washer
- ⑨ Wheel gear (1st)
- ⑩ Wheel gear (5th)
- ⑪ Special washer
- ⑫ Wheel gear (3rd)
- ⑬ Wheel gear (4th)
- ⑭ Wheel gear (6th)
- ⑮ Wheel gear (2nd)
- ⑯ Bearing stopper
- ⑰ Bearing
- ⑱ Main axle
- ⑲ Pinion gear (5th)
- ⑳ Pinion gear (3rd/4th)
- ㉑ Pinion gear (6th)
- ㉒ Pinion gear (2nd)
- ㉓ Bearing

4

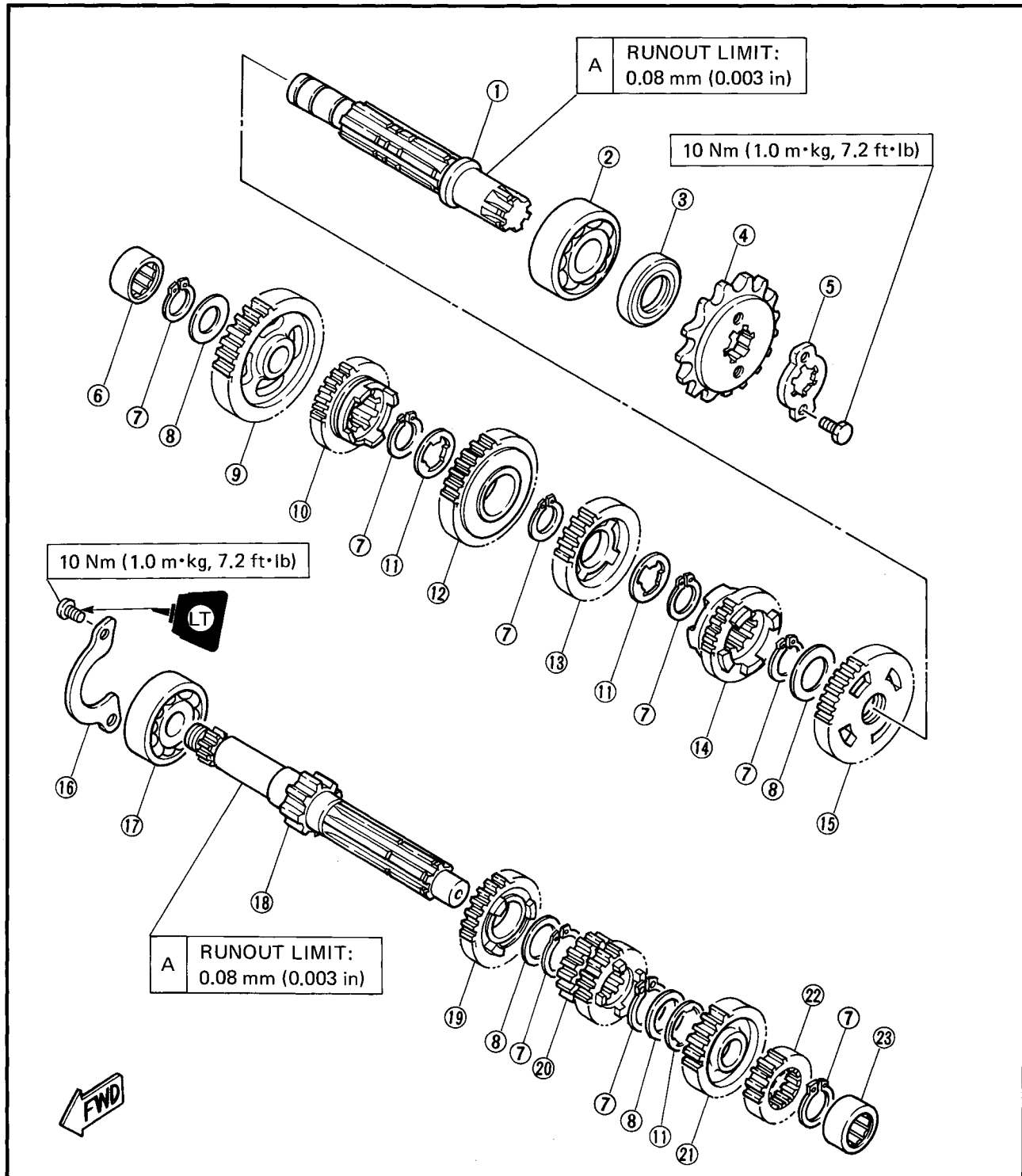



SHIFTER

- ① Circlip
- ② Guide bar 1
- ③ Shift fork (#3)
- ④ Shift fork (#1)
- ⑤ Shift cam
- ⑥ Shift fork (#2)
- ⑦ Guide bar 2
- ⑧ Stopper lever
- ⑨ Spring

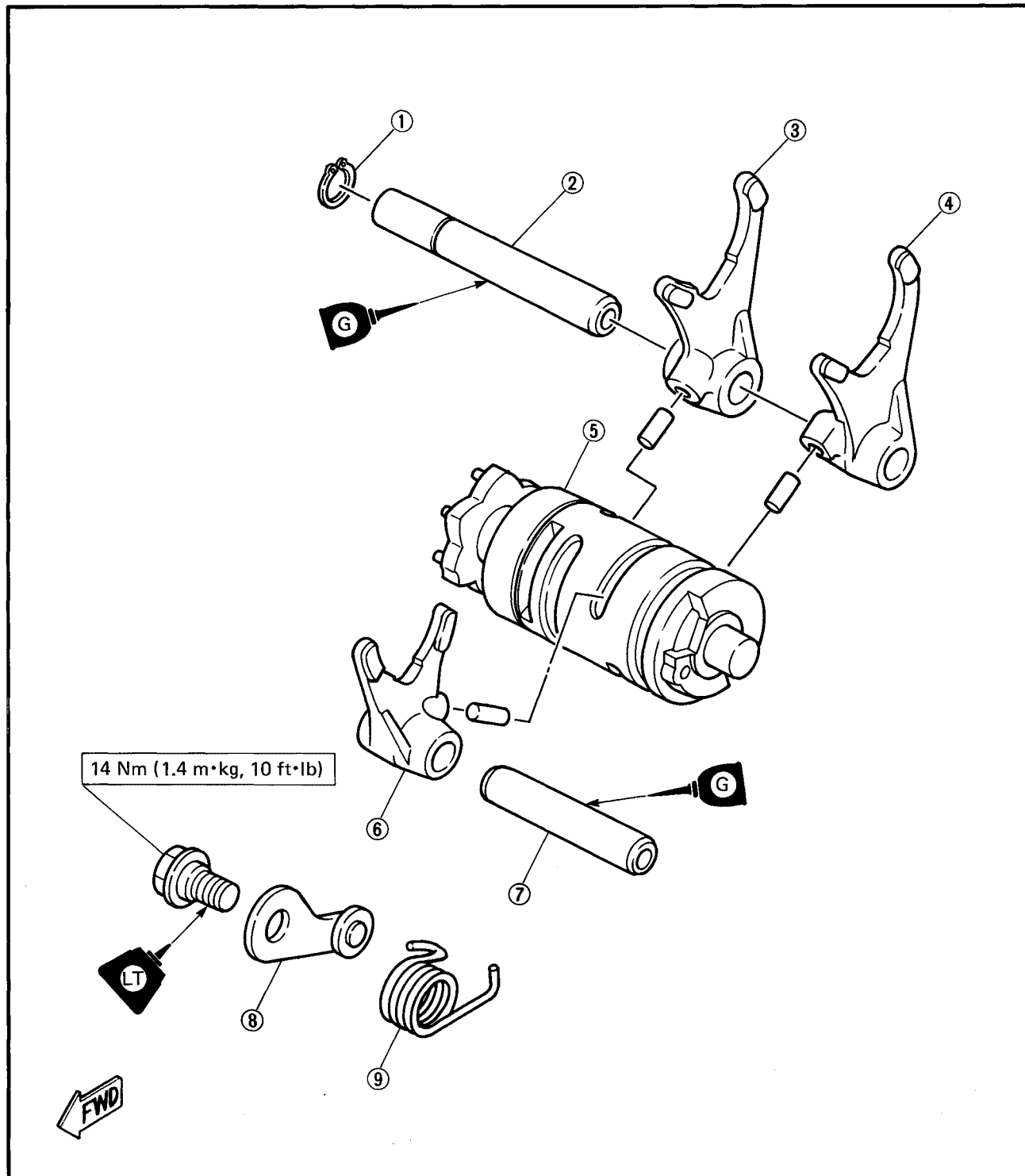

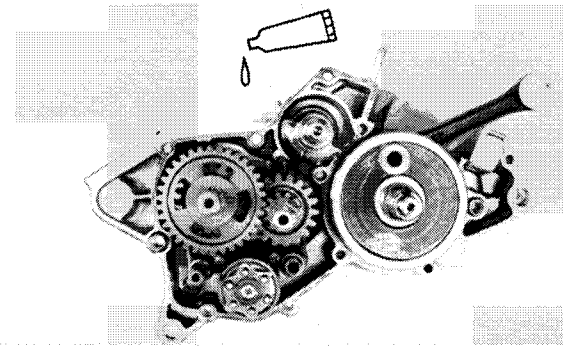

CRANKCASE (RIGHT)

1. Apply:
 - Sealant (Quick Gasket®)
To the mating surfaces of both crankcase halves.

Sealant (Quick Gasket®):
 P/N ACC-11001-05-01
 Yamaha Bond No. 4:
 P/N 90890-05143

2. Install:
 - Dowel pins

3. Install:
 - Crankcase (Right)

Installation step:

- Apply the lithium soap base grease to the oil seal lips.
- Fit the left crankcase onto the right case. Tap lightly on the case with a soft hammer.

NOTE: _____

Turn the shift cam to the position shown in the figure so that it does not contact the crankcase when installing the crankcase.

- Tighten the bolts (Crankcase).

CAUTION: _____

Before installing and torquing the bolts (Crankcase) be sure to check whether the transmission is functioning properly by manually rotating the shift cam either way.

NOTE: _____

Tighten the bolts (Crankcase) in stage, using a crisscross pattern.

Bolts (Crankcase):
 10 Nm (1.0 m·kg, 7.2 ft·lb)

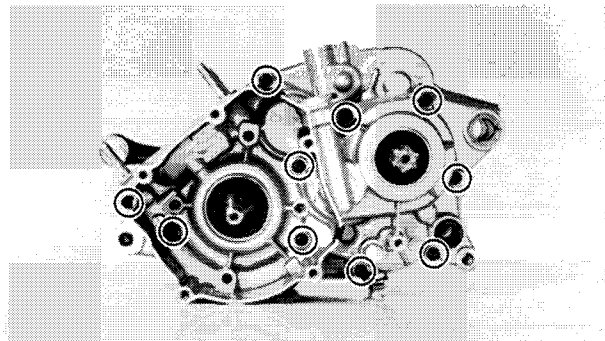
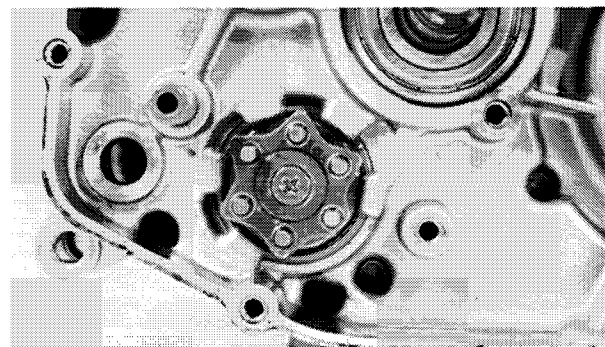

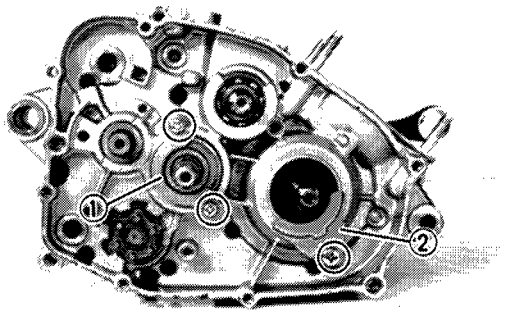

- Install the Bearing stoppers.



Screws (Bearing Stopper ① – Main Axle):

10 Nm (1.0 m·kg, 7.2 ft·lb)

Screw (Bearing Stopper ② – Crankshaft):

16 Nm (1.6 m·kg, 12 ft·lb)

Apply LOCTITE®

4. Apply:

- 2-stroke oil

To the crank pin, bearing and oil delivery hole.

5. Check:

- Crankshaft and transmission operation

Unsmooth operation → Repair.

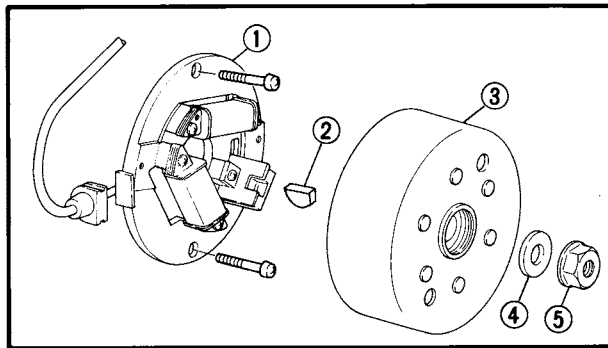

CDI MAGNETO

1. Install:

- Stator assembly ①
- Key ②
- Rotor ③
- Washer ④
- Nut ⑤



Screws (Stator Assembly):

8 Nm (0.8 m·kg, 5.8 ft·lb)

Use LOCTITE®

NOTE:

- When installing the CDI magneto, make sure the key is properly seated in the key way of the crankshaft. Apply a light coating of lithium soap base grease to the tapered portion of the crankshaft end.

- Hold the rotor by the Rotor Holder ① to tighten the nut ②.

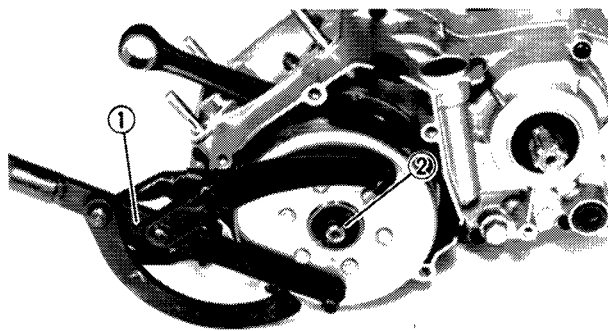

Rotor Holder:

P/N YU-01235

P/N 90890-01235



Nut (Rotor):

73 Nm (7.3 m·kg, 53 ft·lb)



CDI MAGNETO

- ① Stator assembly
- ② Rotor
- ③ Washer

4

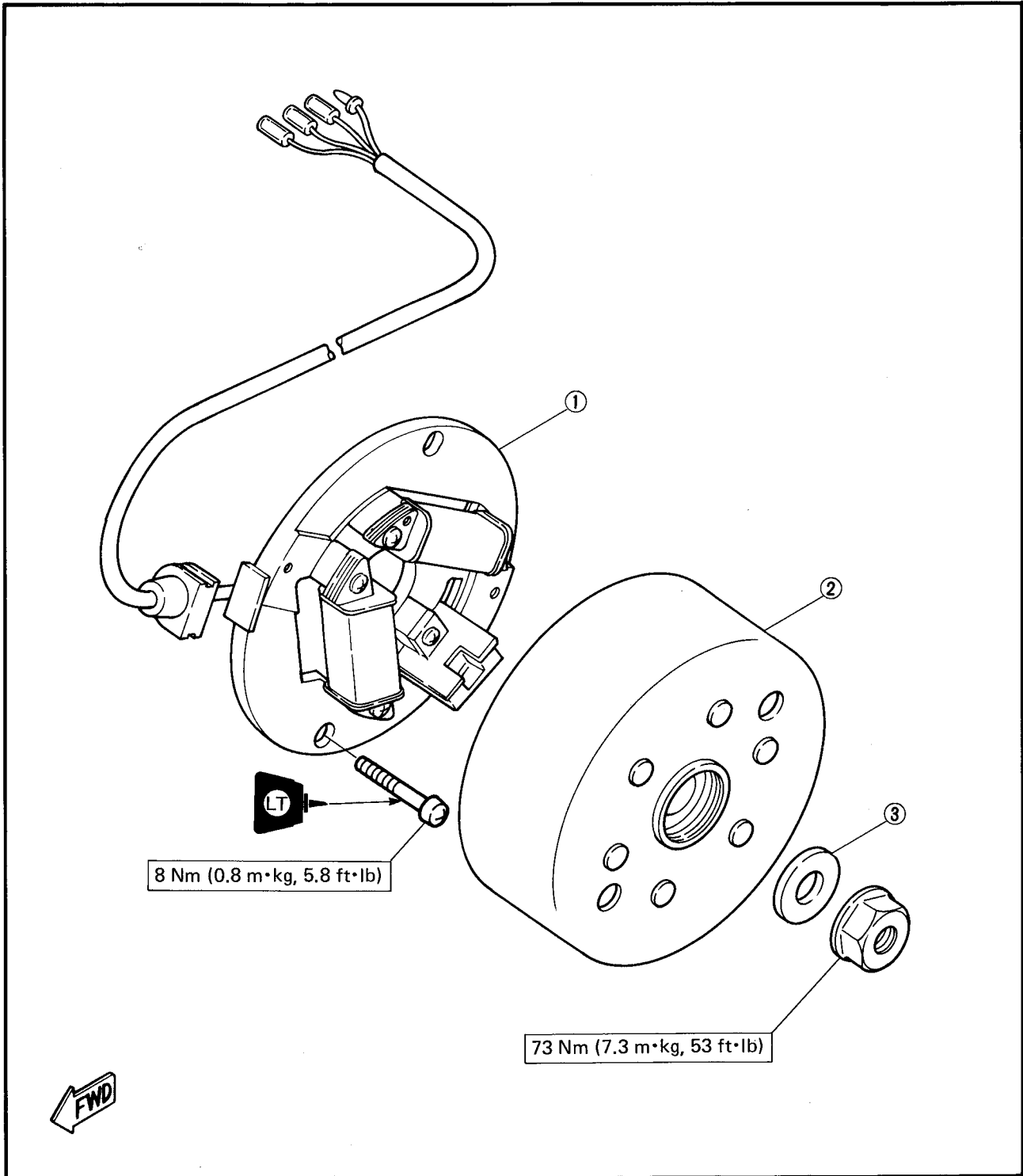

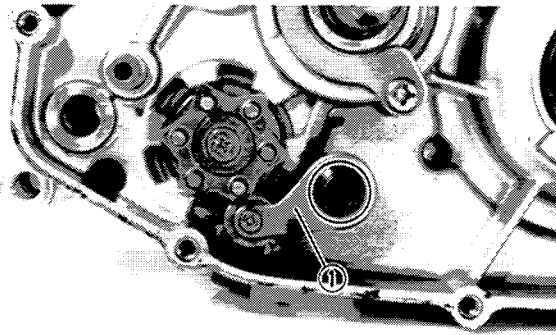

STOPPER LEVER AND SHIFT SHAFT

1. Install:
 - Spring
 - Stopper lever ①
2. Set the stopper lever and torsion spring as properly position.

Bolt (Stopper Lever):
14 Nm (1.4 m·kg, 10 ft·lb)
Apply LOCTITE®

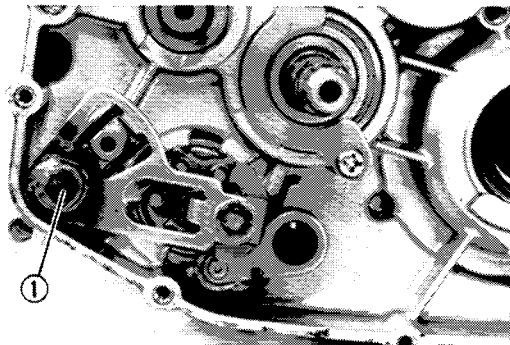

3. Install:
 - Spring
 - Shift shaft ①

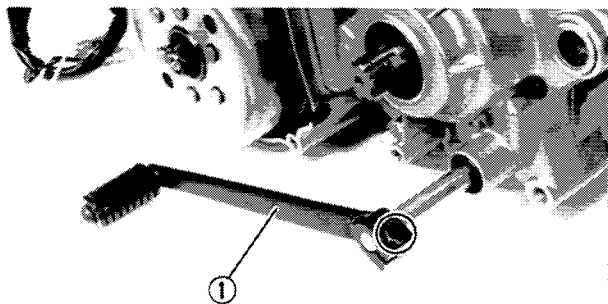

4. Install:
 - Change pedal ①
5. Check:
 - Change operation
 Unsmooth operation → Repair.

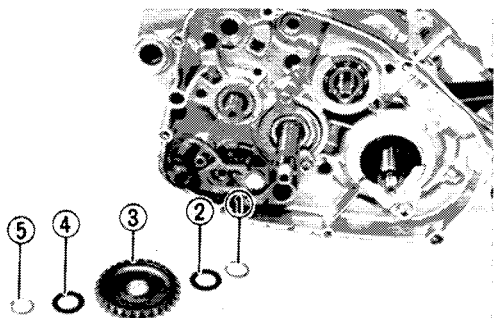

KICK AXLE

1. Install:
 - Circlip ①
 - Plain washer ②
 - Kick idle gear ③
 - Plain washer ④
 - Circlip ⑤

4



SHIFT SHAFT

- ① Shift shaft
- ② Spring
- ③ Circlip
- ④ Oil seal
- ⑤ Change pedal

4

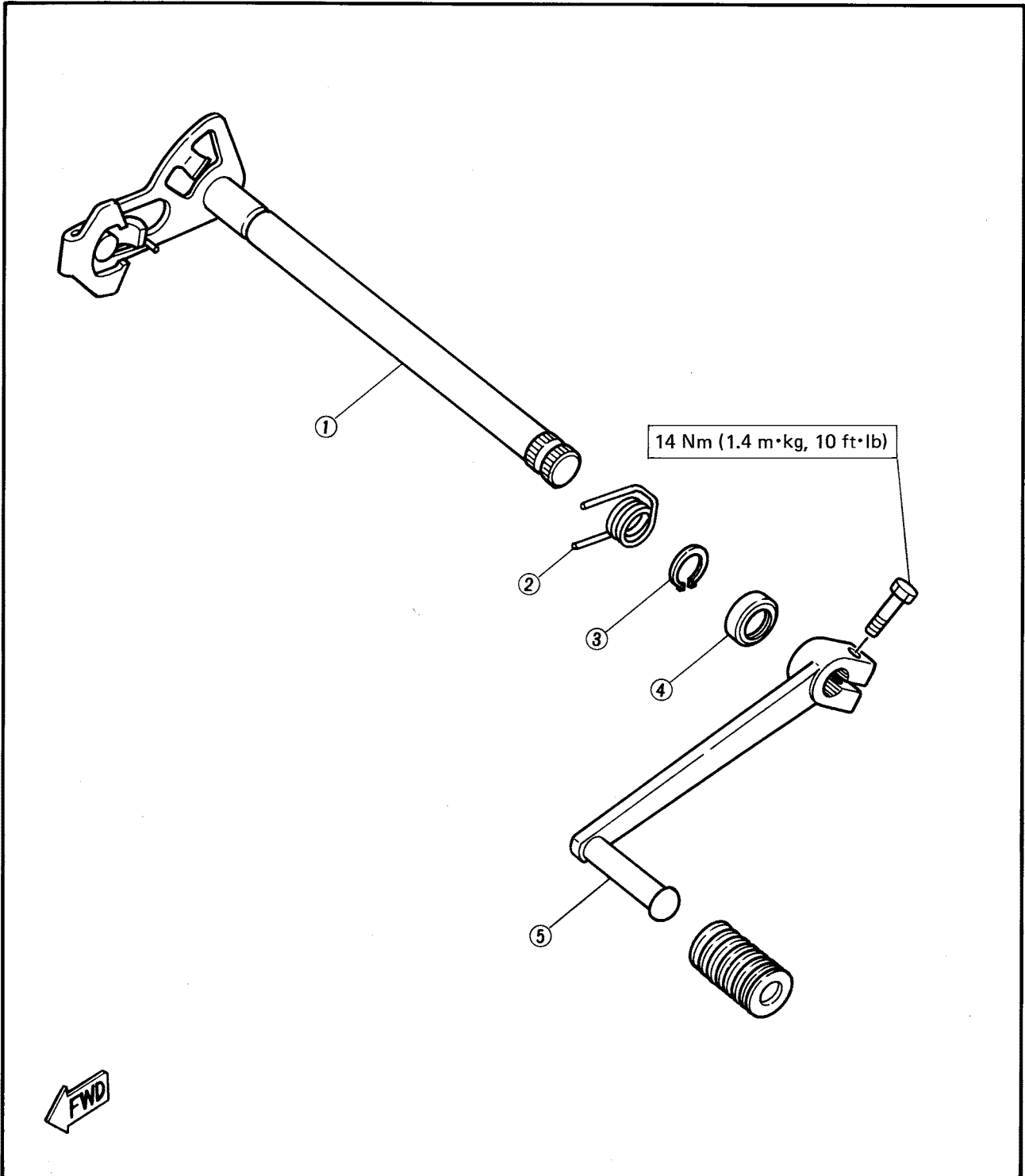



KICK AXLE

- ① Kick crank
- ② Oil seal
- ③ Spring guide
- ④ Kick spring
- ⑤ Washer
- ⑥ Kick gear
- ⑦ Clip
- ⑧ Kick axle
- ⑨ Circlip
- ⑩ Washer
- ⑪ Kick idle gear

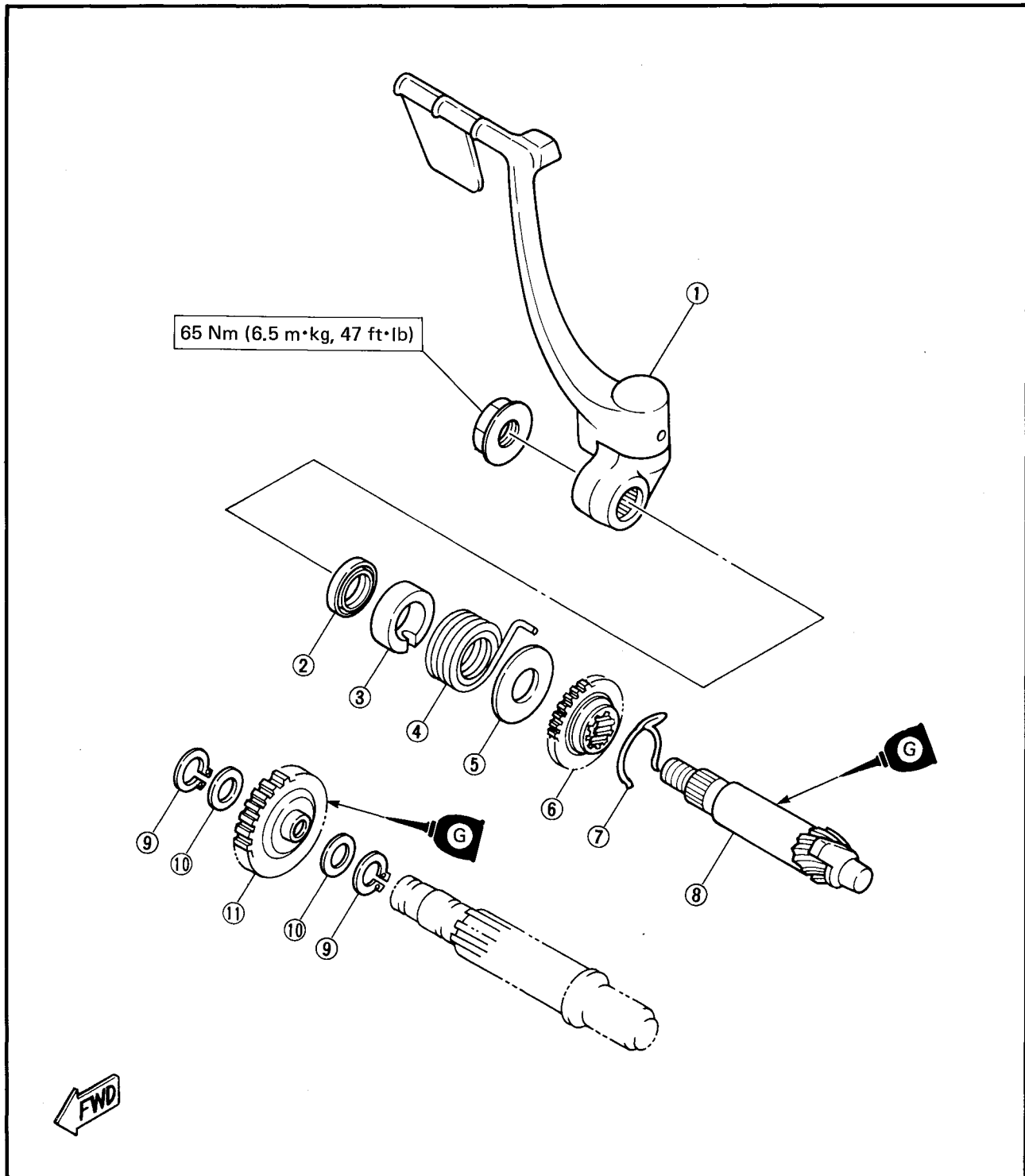

4

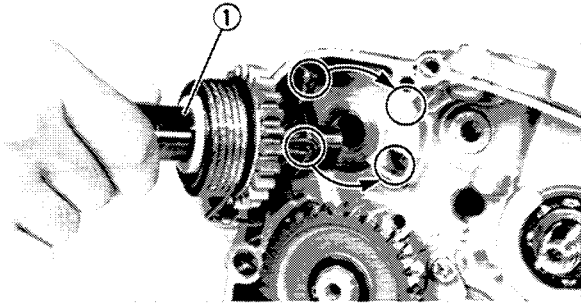

2. Install:
 - Kick axle assembly ①
 - Rotate the shaft clockwise.

NOTE: _____

- Make sure that the kick stopper is stopped at the projection of the crankcase.
- Make sure that the spring is engaged with the crankcase hole.

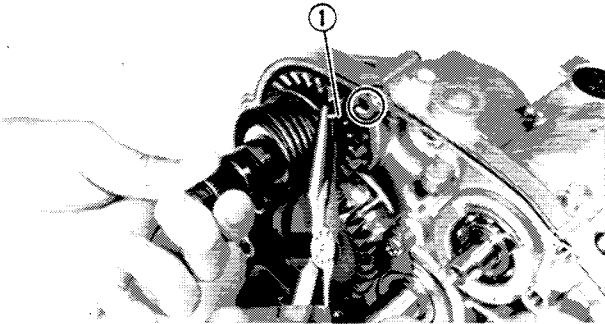

3. Set the kick spring ① to the spring hook.

4. Check:
 - Kick axle operation
 - Unsmooth operation → Repair.

4

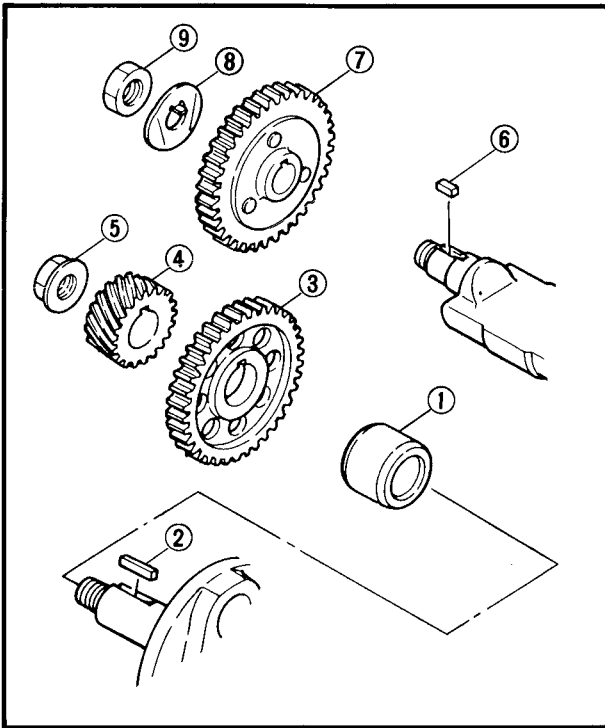

PRIMARY DRIVE GEAR AND BALANCER GEAR

1. Install:
 - Collar ①
 - Key ②
 - Balancer drive gear ③
 - Primary drive gear ④
 - Nut ⑤ (Primary drive gear)
 - Key ⑥
 - Balancer gear ⑦
 - Lock washer ⑧
 - Nut ⑨ (Balancer gear)

NOTE: _____

Note that there is the punched mark ① on the drive gear and punched mark ① on the balancer gear which must be aligned to install the balancer gear.

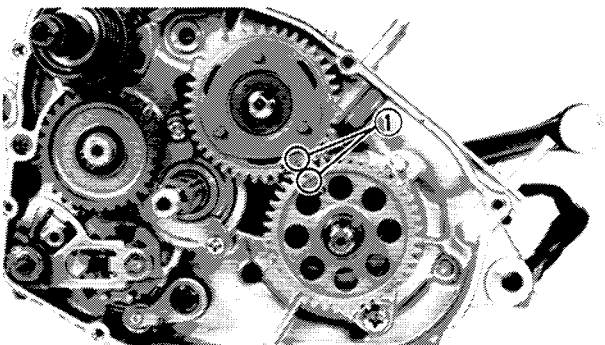

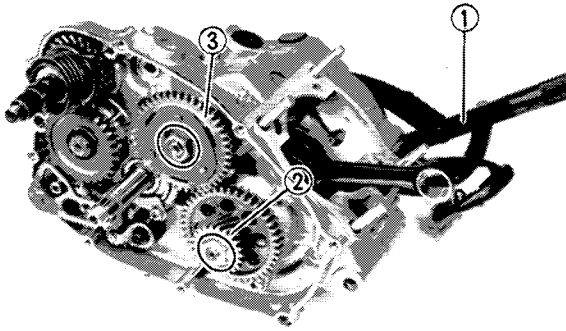
**NOTE:**

- Hold the rotor (CDI magneto) by the Rotor Holder ① to tighten the nuts (Primary drive gear ② and balancer gear ③).



Rotor Holder:
P/N YU-01235
P/N 90890-01235

- Tighten both the nuts simultaneously (Primary drive gear and balancer gear).



Nut (Primary Drive Gear):
80 Nm (8.0 m·kg, 58 ft·lb)
Nut (Balancer Gear):
55 Nm (5.5 m·kg, 40 ft·lb)

2. Bend the lock washer tab.

⚠ WARNING:

Always use a new lock washer.

4

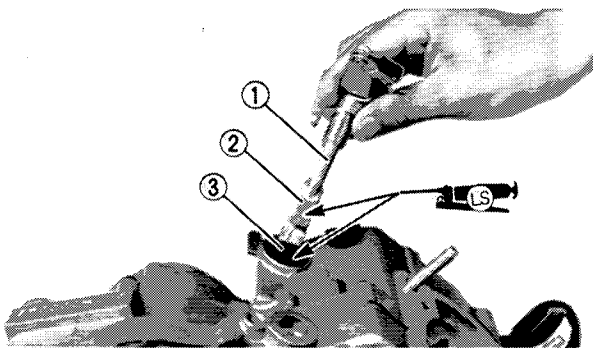
**CLUTCH**

1. Install:

- Push lever ①

2. Apply:

- Lithium soap base grease
To push lever surface ② and bearing ③.

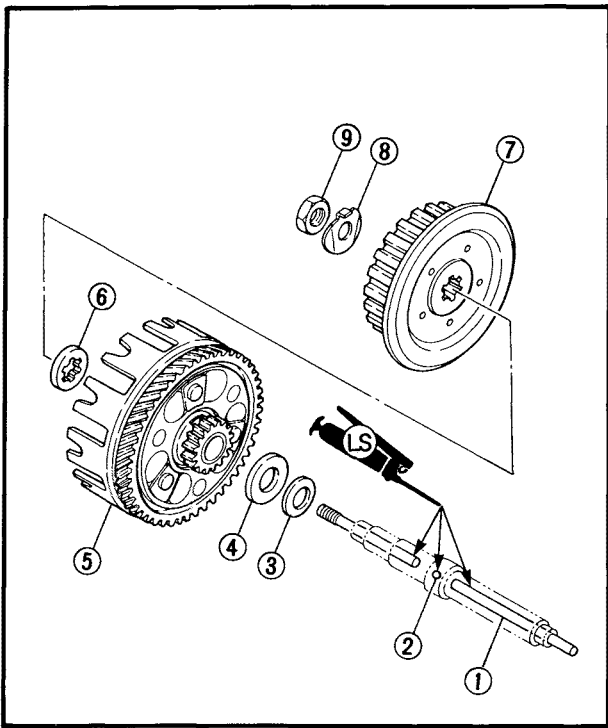

3. Install:
 - Push rod ①
 - Ball ②
 - Conical spring washer ③
 - Spacer ④
 - Clutch housing ⑤
 - Spacer ⑥
 - Clutch boss ⑦
 - Lock washer ⑧
 - Nut ⑨ (Clutch boss)
4. Apply:
 - Lithium soap base grease
To push rod ① and ball ② .

4

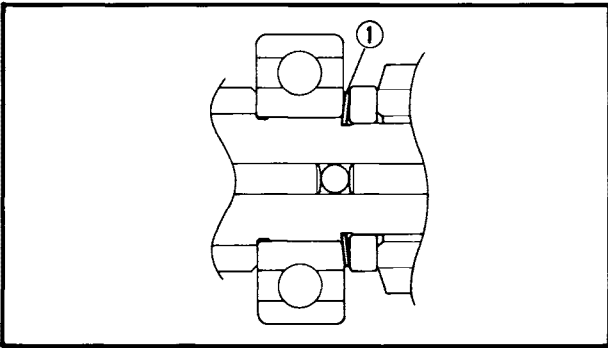

- NOTE:** _____
- Be careful to install the conical spring washer ① in proper position as shown.
 - Install the lock washer tab into the hole of the clutch boss.

⚠ WARNING: _____

Always use a new lock washer.

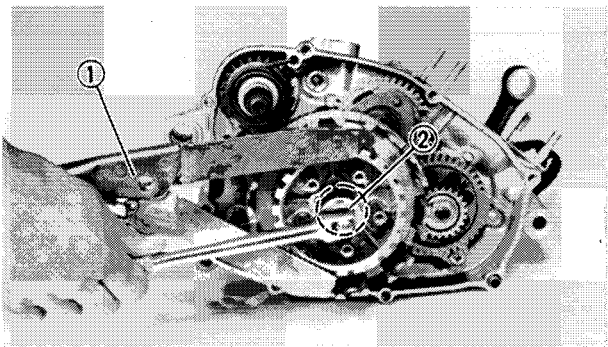

- NOTE:** _____
- Hold the clutch boss by the Universal Clutch Holder ① to tighten the nut ② (Clutch boss).

	<p>Universal Clutch Holder: P/N YM-91042 P/N 90890-04086</p>
--	---

	<p>Nut (Clutch Boss): 80 Nm (8.0 m·kg, 58 ft·lb)</p>
--	---

- Bend the lock washer tab.

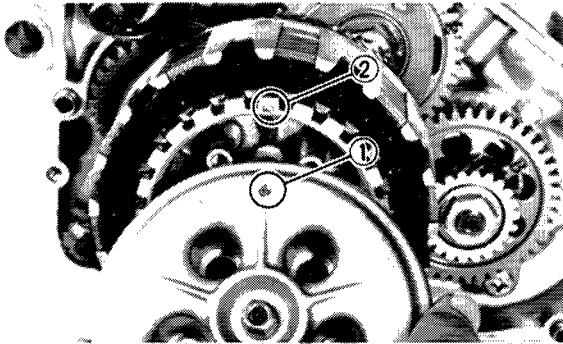
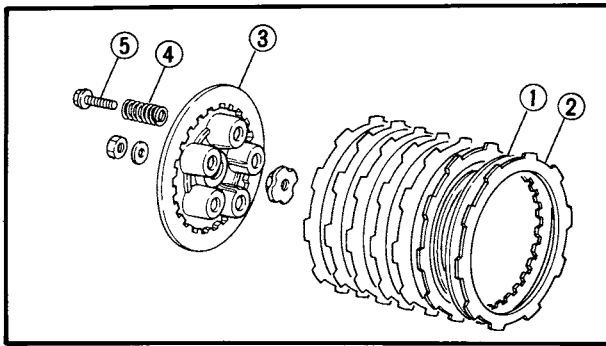

5. Install:

- Clutch plates ①
- Friction plates ②
- Pressure plate ③
- Clutch springs ④
- Bolts ⑤

NOTE:

- Align the pressure plate mark ① with the clutch boss mark ② .

6. Tighten:

- Bolts (Pressure plate)



Bolts (Pressure Plate):
6 Nm (0.6 m·kg, 4.3 ft·lb)

NOTE:

Tighten the bolts (Pressure plate) in stage, using a crisscross pattern.

7. Install:

- Dowel pins
- Gasket
- Crankcase cover ① (Right)
- Kick crank ②

NOTE:

Tighten the bolts (Crankcase Cover – Right) in stage, using a crisscross pattern.



Bolts (Crankcase Cover – Right):
10 Nm (1.0 m·kg, 7.2 ft·lb)

Bolt (Kick Crank):
65 Nm (6.5 m·kg, 47 ft·lb)

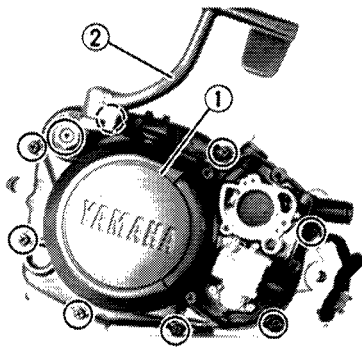

⚠ WARNING:

Always use a new gasket.



CLUTCH

- ① Clutch spring
- ② Pressure plate
- ③ Push plate
- ④ Cushion spring
- ⑤ Clutch plate
- ⑥ Friction plate
- ⑦ Clutch boss
- ⑧ Spacer
- ⑨ Clutch housing
- ⑩ Spacer
- ⑪ Conical spring washer
- ⑫ Push rod (#1)
- ⑬ Ball
- ⑭ Push rod (#2)
- ⑮ Push lever
- ⑯ Primary drive gear

4

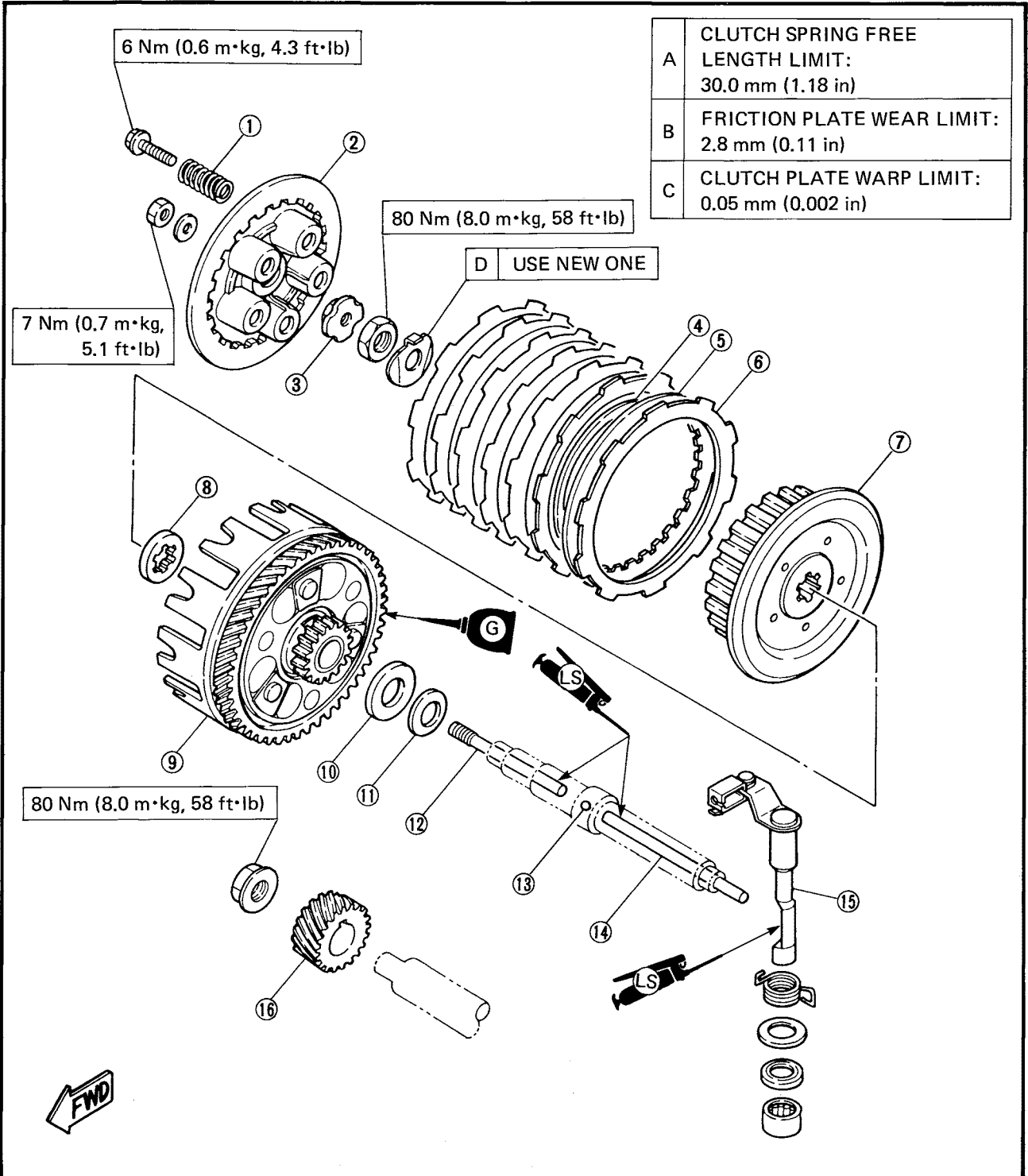

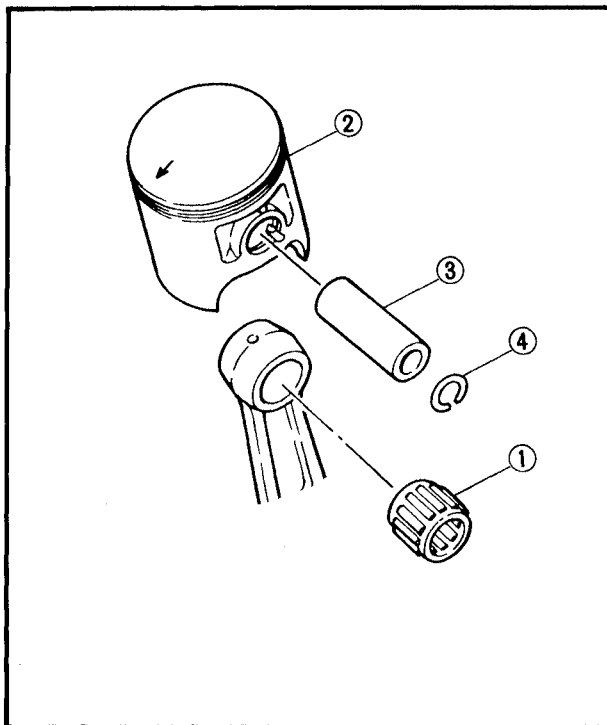

CYLINDER HEAD, CYLINDER AND PISTON

1. Install:

- Bearing ①
- Piston ②
- Piston pin ③
- Piston pin clip ④

NOTE:

- Apply 2-stroke oil to the piston pin, bearing, piston ring grooves and piston skirt areas.
- The arrow on the piston must point to the front of the engine.
- Before installing the piston pin clip, cover the crankcase with a clean towel or rag so you will not accidentally drop the pin clip and material into the crankcase.

⚠ WARNING:

Always use a new piston pin clip.

4

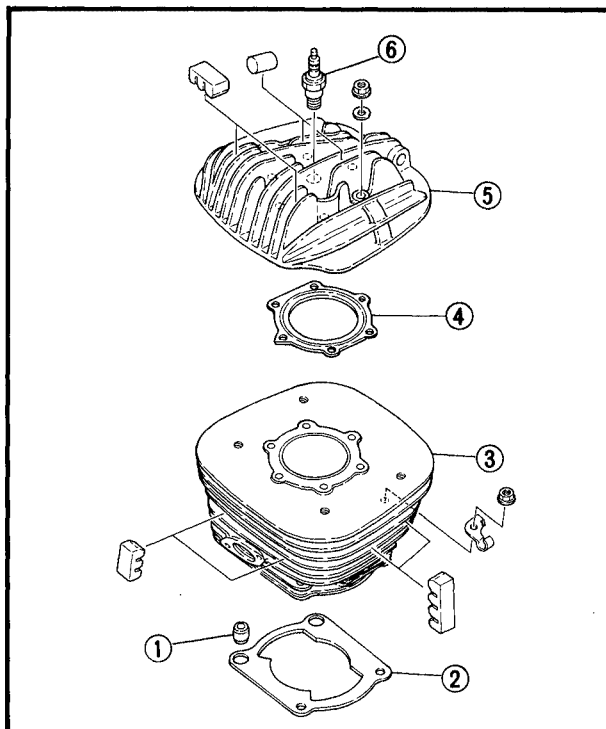

2. Install:

- Dowel pins ①
- Gasket ②
- Cylinder ③
- Gasket ④
- Cylinder head ⑤
- Spark plug ⑥

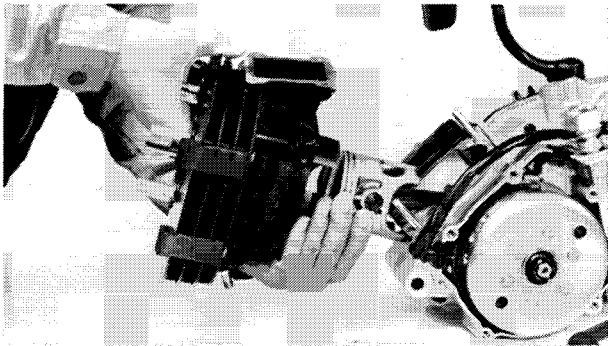
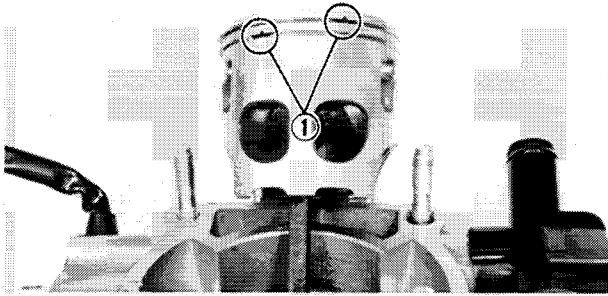

NOTE: _____

- Be sure to check the manufacturer's marks or numbers stamped on the rings are on the top side of the rings.
- Make sure the ring ends ① are properly fitted around the ring locating pins in the piston grooves.
- Before installing the cylinder, apply a liberal coating of 2-stroke oil to the piston rings.
- Install the cylinder with one hand while compressing the piston rings with the other hand.

⚠ WARNING: _____

Always use a new gasket.

4

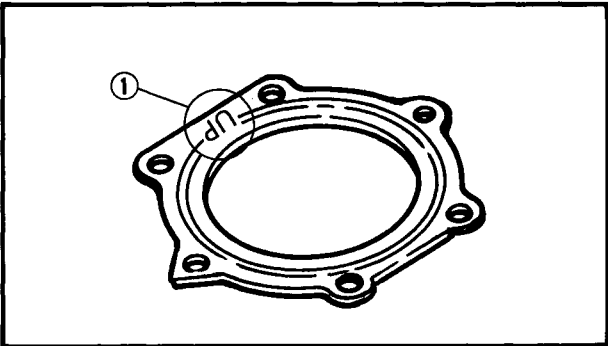

NOTE: _____

Install the gasket (Cylinder head) with the "UP" mark ① faced upward.

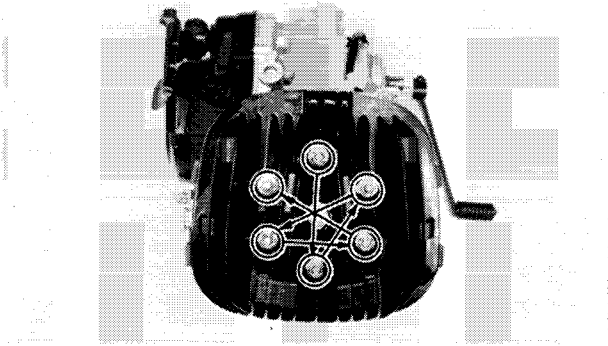

3. Tighten:

- Nuts (Cylinder)
- Nuts (Cylinder head)
- Spark plug

	Nuts (Cylinder): 25 Nm (2.5 m·kg, 18 ft·lb)
	Nuts (Cylinder Head): 27 Nm (2.7 m·kg, 20 ft·lb)
	Spark Plug: 25 Nm (2.5 m·kg, 18 ft·lb)



CYLINDER HEAD AND CYLINDER

- ① Spark plug
- ② Cylinder head
- ③ Gasket
- ④ Cylinder
- ⑤ Dowel pin
- ⑥ Gasket

A	CYLINDER HEAD WARPAGE LIMIT: 0.03 mm (0.0012 in)
B	CYLINDER BORE: 66.00 ~ 66.02 mm (2.598 ~ 2.599 in)

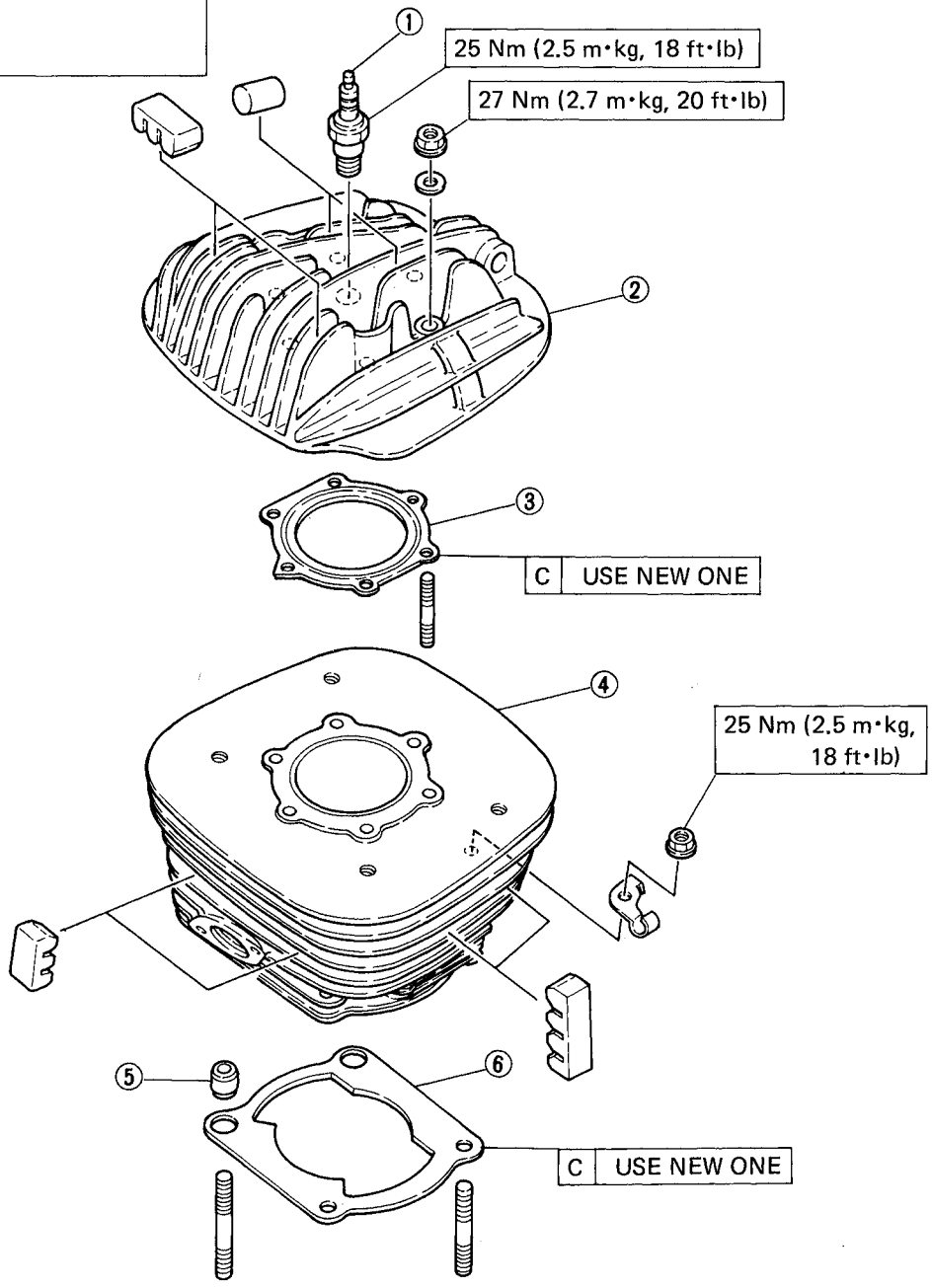

4

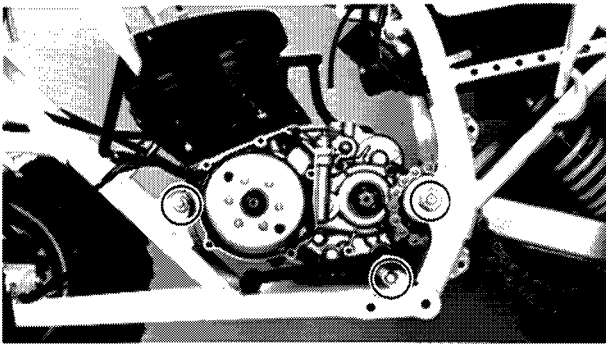

REMounting ENGINE

Reverse the "ENGINE REMOVAL" procedure. Note the following points.

1. Install:
 - Engine assembly
 - Mounting bolts

NOTE:

- Apply lithium soap base grease to the bolt (Pivot shaft).
- Temporary tighten the bolts before tightening them to specification.



Mounting Bolts:

Front:

45 Nm (4.5 m·kg, 33 ft·lb)

Rear:

33 Nm (3.3 m·kg, 24 ft·lb)

Pivot Shaft:

85 Nm (8.5 m·kg, 61 ft·lb)

4

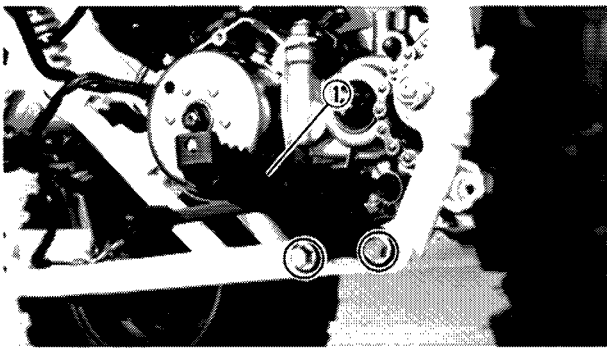

2. Install:

- Footrest ① (Left)



Bolts (Footrest):

55 Nm (5.5 m·kg, 40 ft·lb)

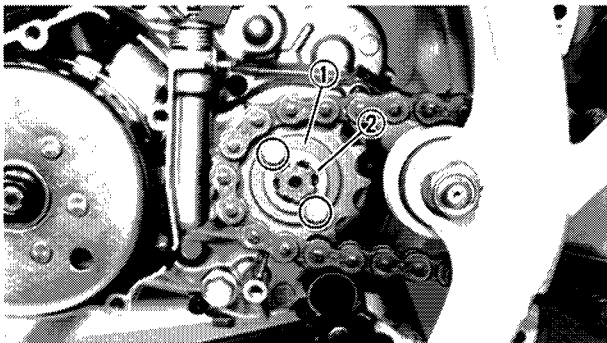

3. Install:

- Drive sprocket ①
- Sprocket holder ②



Bolts (Sprocket Holder):

10 Nm (1.0 m·kg, 7.2 ft·lb)

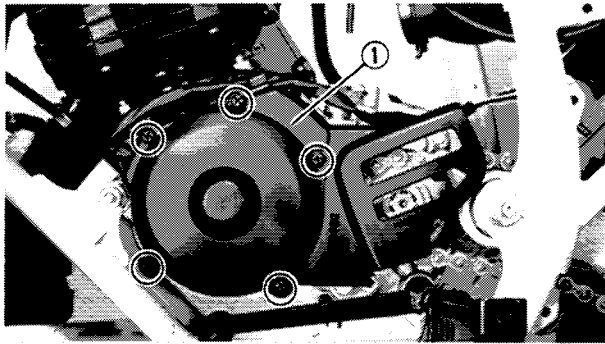

4. Install:

- Crankcase cover ① (Left)



Bolts (Crankcase Cover – Left):
10 Nm (1.0 m·kg, 7.2 ft·lb)

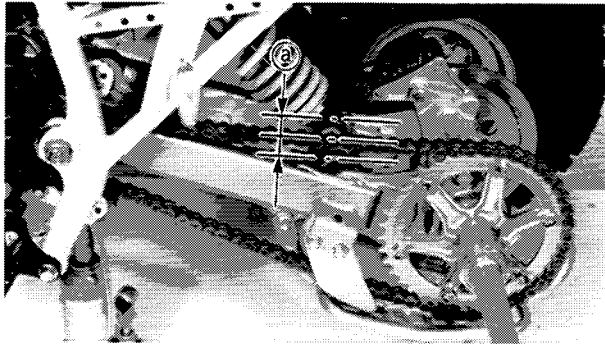

5. Adjust:

- Drive chain slack ②



Drive Chain Slack:
30 ~ 40 mm (1.18 ~ 1.57 in)

Refer to "DRIVE CHAIN SLACK ADJUSTMENT" section in CHAPTER 3.

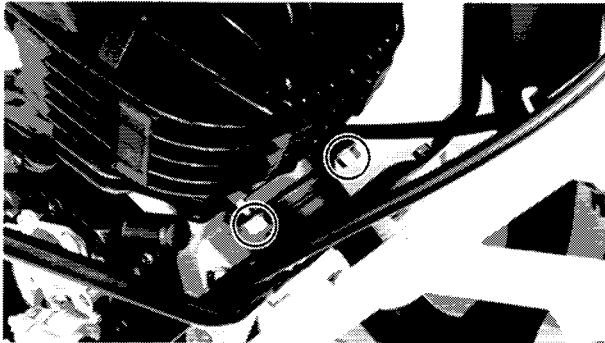

6. Install:

- Exhaust pipe



Nuts (Exhaust Pipe):
21 Nm (2.1 m·kg, 15 ft·lb)

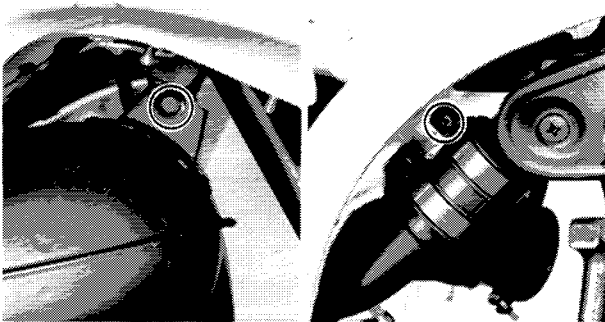

7. Connect:

- Oil hose ①
- Oil delivery hose ②

8. Air bleed:

- Autolube pump

Refer to "AUTOLUBE PUMP AIR BLEEDING" section in CHAPTER 3.

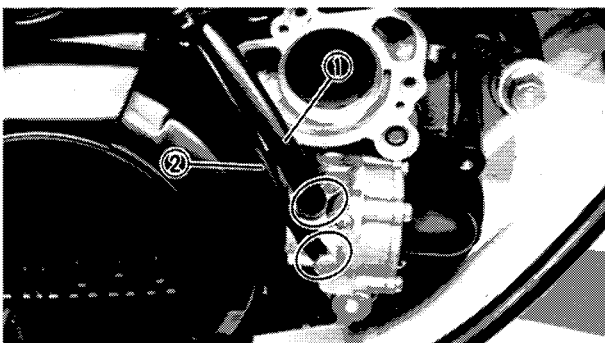

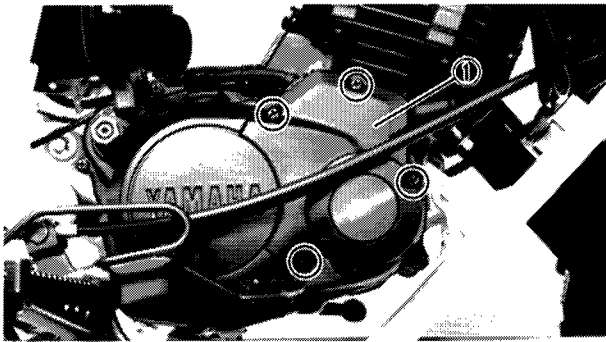

9. Install:
- Cover ① (Autolube pump)

	Bolts (Autolube Pump Cover): 7 Nm (0.7 m·kg, 5.1 ft·lb)
---	---

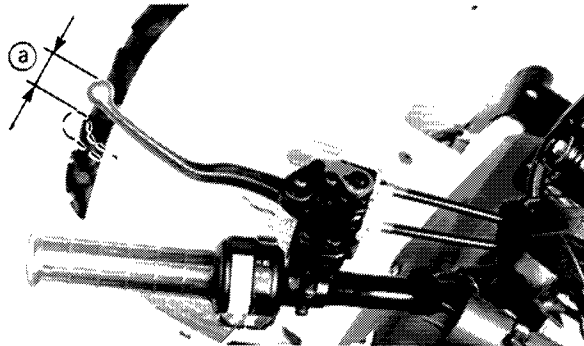

10. Adjust:
- Clutch lever free play ②

	Clutch Lever Free Play: 5 ~ 8 mm (0.20 ~ 0.31 in)
---	---

4

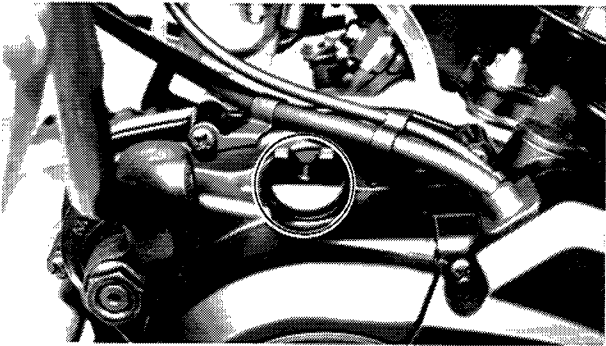

11. Fill:
- Crankcase

	Total Amount: 0.70 L (0.62 Imp qt, 0.74 US qt)
--	--

Refer to "TRANSMISSION OIL REPLACEMENT" section in CHAPTER 3.



CARBURETION

CARBURETOR

- ① Carburetor switch
- ② Top cover
- ③ Throttle valve spring
- ④ Jet needle
- ⑤ Throttle valve
- ⑥ Main nozzle
- ⑦ Pilot air screw
- ⑧ Starter plunger
- ⑨ Valve seat
- ⑩ Needle valve
- ⑪ Main jet
- ⑫ Main jet ring
- ⑬ Pilot jet
- ⑭ Float
- ⑮ Float pin
- ⑯ Gasket
- ⑰ Float chamber
- ⑱ Drain screw

SPECIFICATIONS		
Main Jet (M.J.)	#220	
Main Air Jet (M.A.J.)	φ0.7	
Jet Needle (J.N.)	5J22-2	
Needle Jet (N.J.)	P-6 (#345)	
Pilot Jet (P.J.)	#32.5	
Pilot Air Screw (P.A.S.)	1 and 1/2 turns out	
Float Height (F.H.)	20.0 ~ 21.5 mm (0.79 ~ 0.85 in)	
Fuel Level (F.L.)	0.5 ~ 1.5 mm (0.02 ~ 0.06 in)	
Engine Idling Speed	1,450 ~ 1,550 r/min	

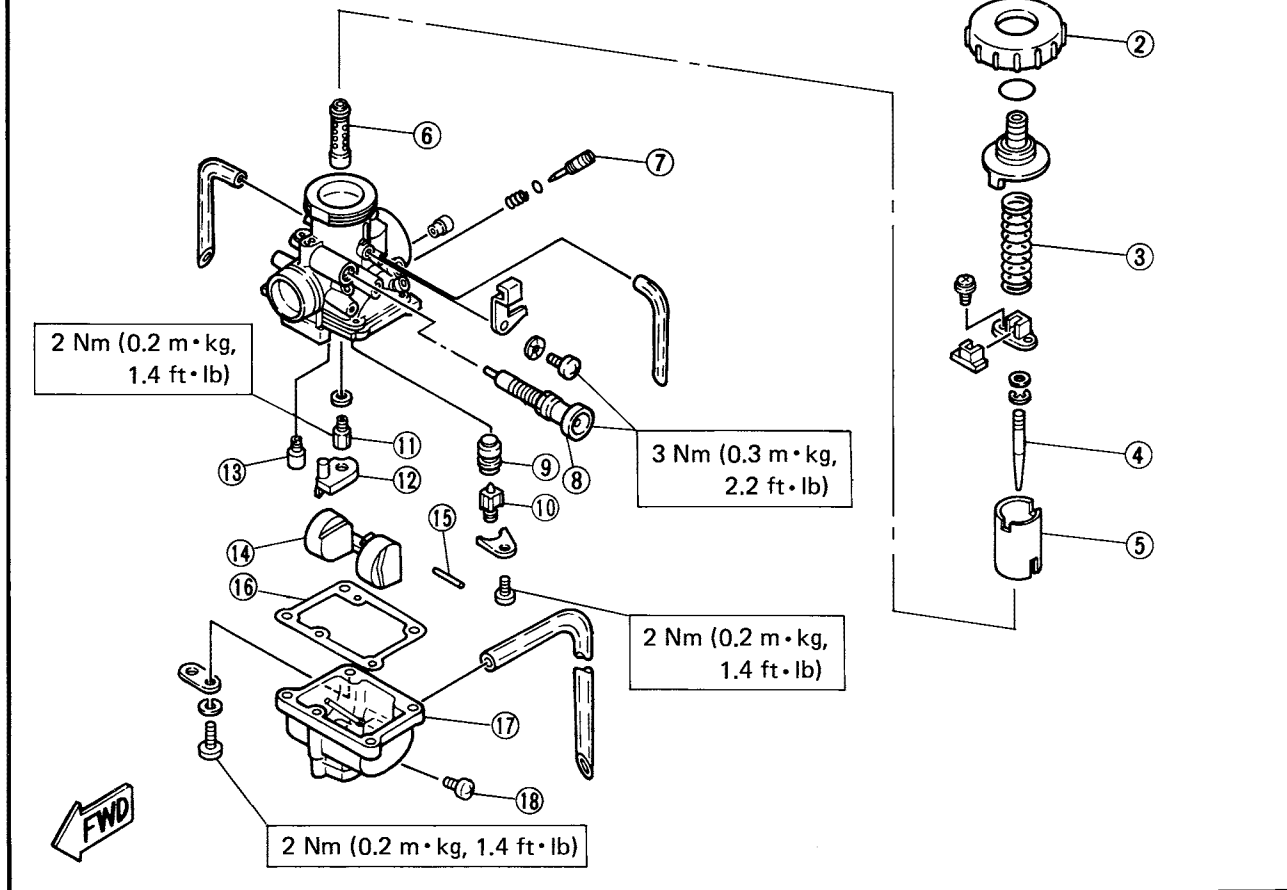
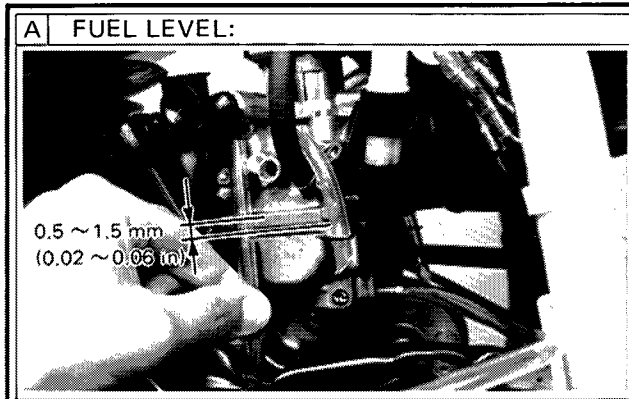

5



SECTIONAL VIEW

- ① Pilot outlet
- ② Bypass hole
- ③ Pilot jet
- ④ Main jet
- ⑤ Main nozzle
- ⑥ Needle valve
- ⑦ Jet needle
- ⑧ Main air jet
- ⑨ Throttle valve
- ⑩ Starter jet
- ⑪ Starter plunger

5

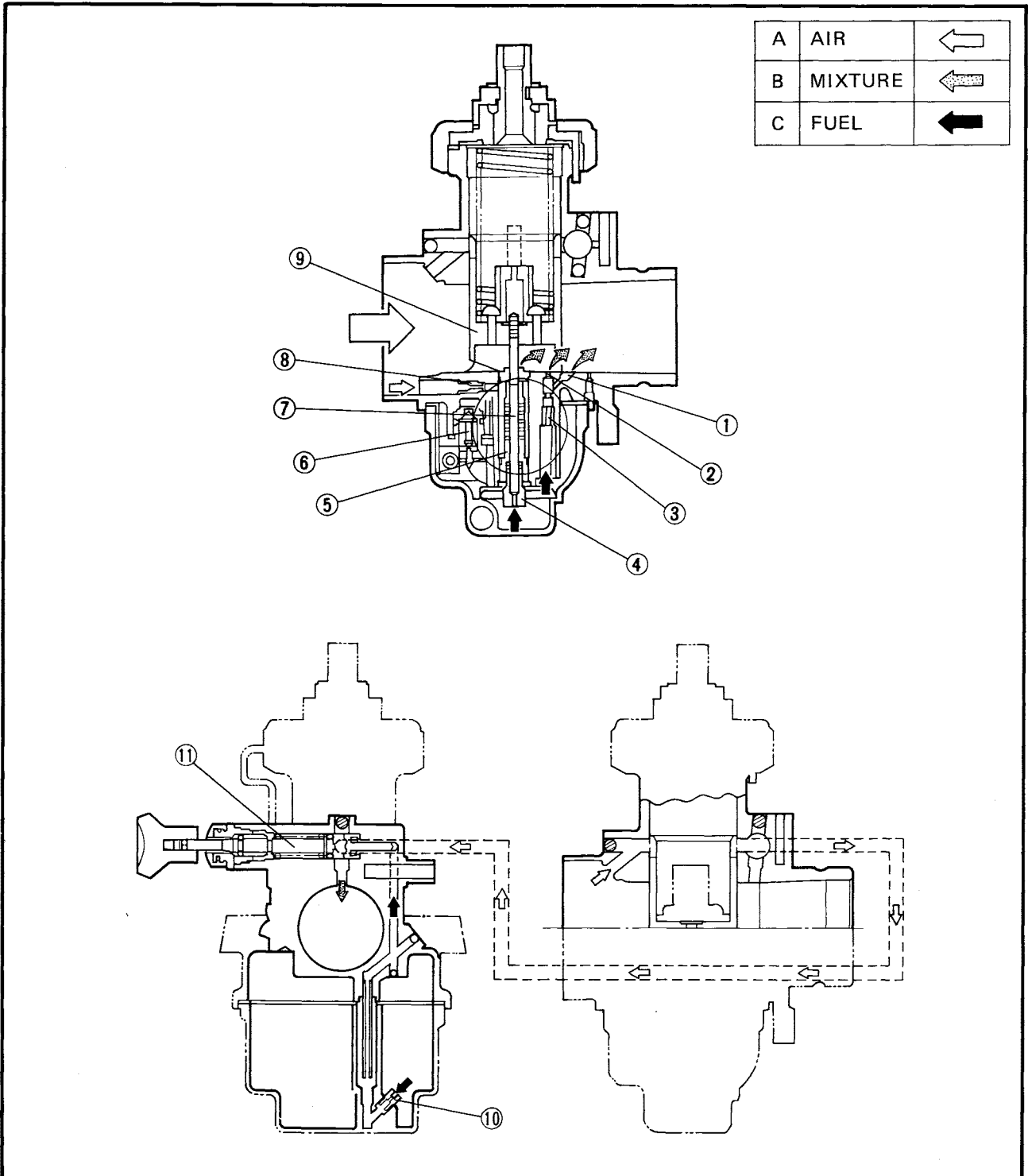



REMOVAL

NOTE:

The following parts can be cleaned and inspected without disassembly.

- Starter plunger
- Pilot air screw

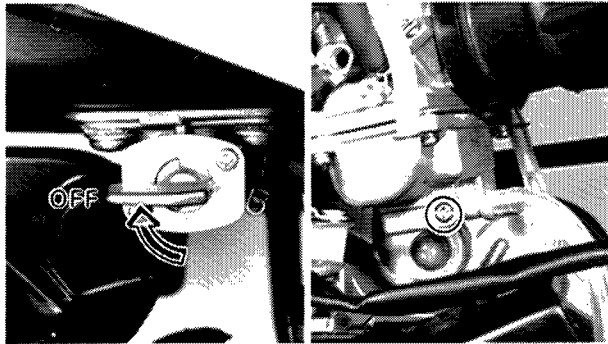

1. Turn the fuel cock to off.
2. Drain:
 - Fuel
 From float chamber.

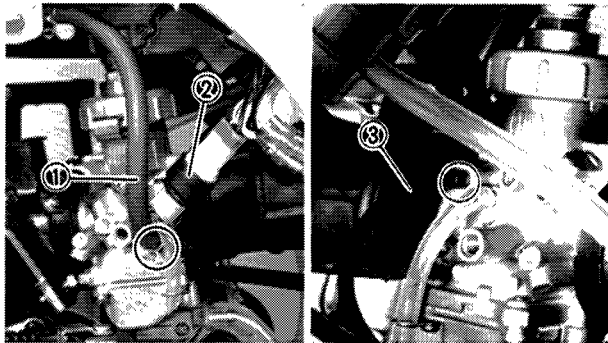

3. Disconnect:
 - Fuel hose ①
 - Carburetor switch coupler ②
 - Oil delivery hose ③

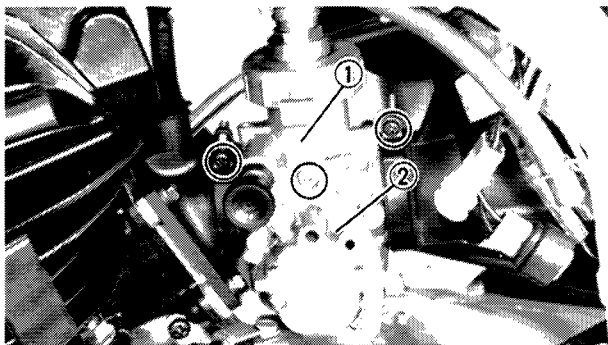

4. Remove:
 - Stopper plate ①
 - Carburetor assembly ②

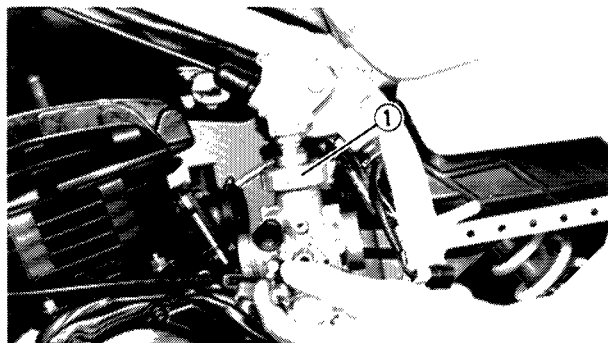

5. Remove:
 - Top cover ①

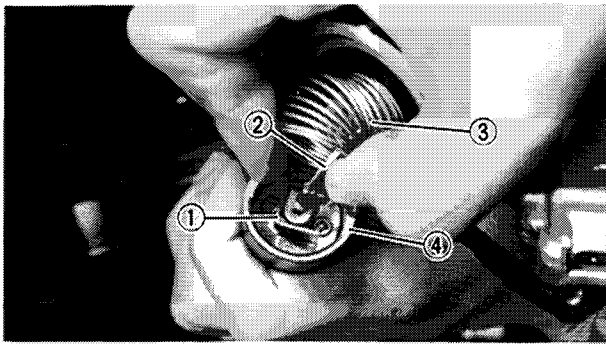

6. Remove:
- Holder ①
 - Throttle cable ②
 - From throttle valve.
 - Spring ③
 - Throttle valve ④

DISASSEMBLY

1. Remove:
- Float chamber ①

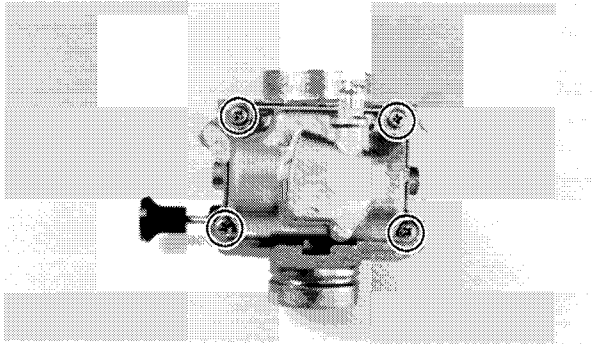

2. Remove:
- Float pin ①
 - Float ②
 - Needle valve

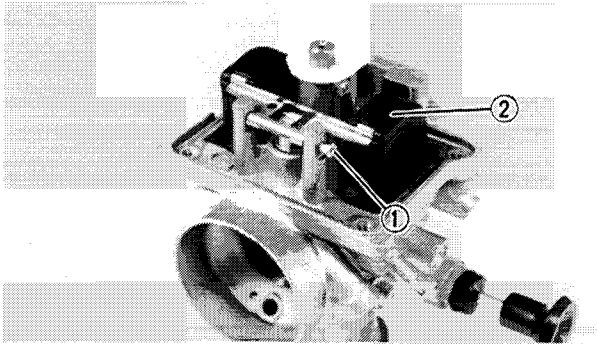

3. Remove:
- Valve seat ①

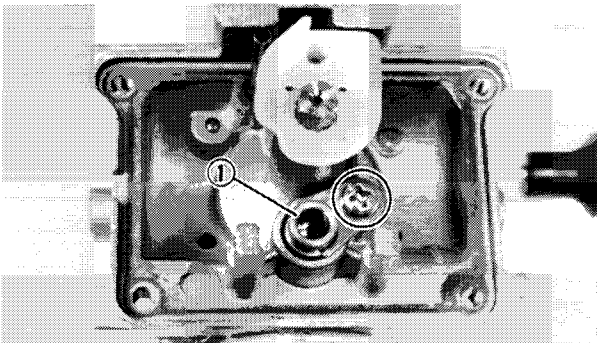

4. Remove:
- Main jet ring ①
 - Main jet ②
 - Main nozzle ③

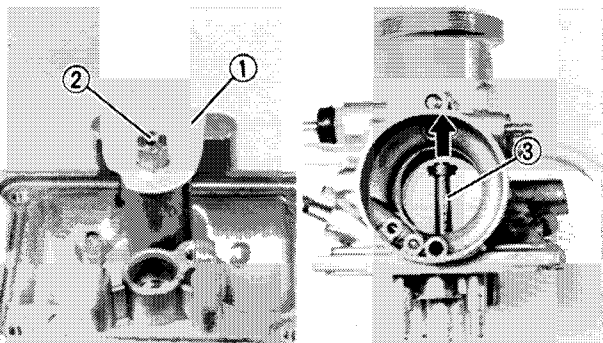

5

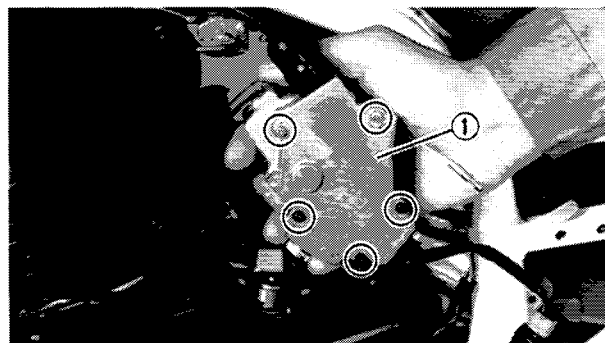
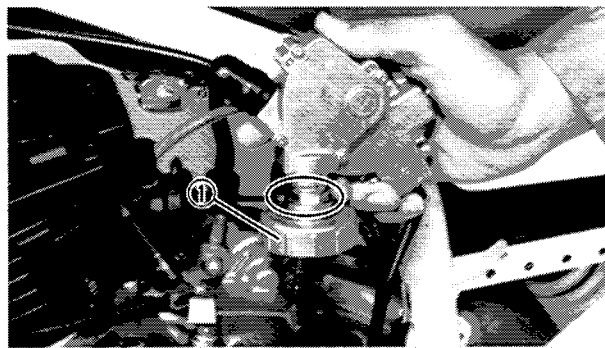
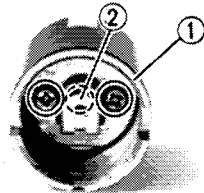
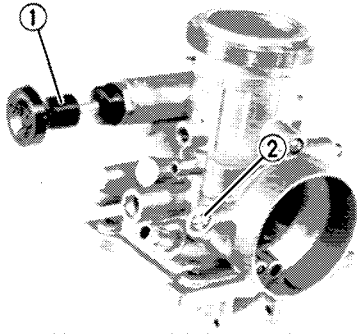
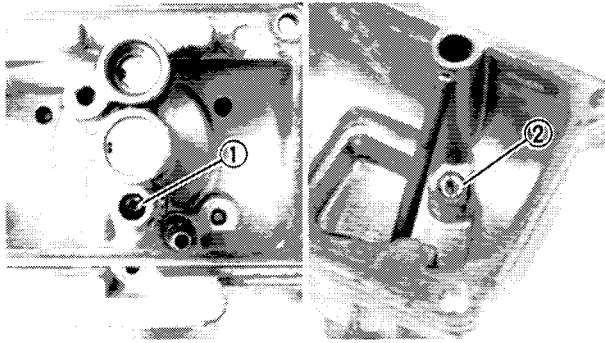

5. Remove:
- Pilot jet ①
 - Starter jet ②

6. Remove:
- Starter plunger ①
 - Pilot air screw ②

7. Remove:
- Throttle valve ①
 - Jet needle ②

8. Remove:
- Carburetor top ①

9. Remove:
- Cover (Carburetor switch – Right) ①

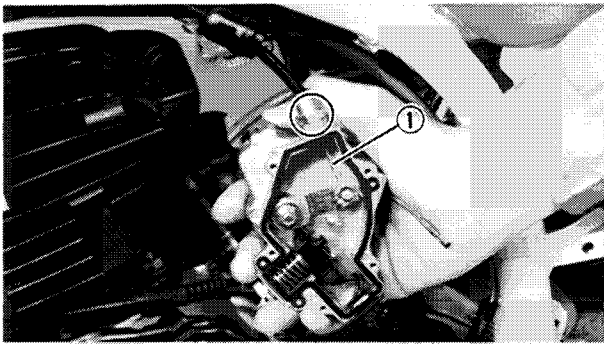

10. Remove:
- Throttle cable ①

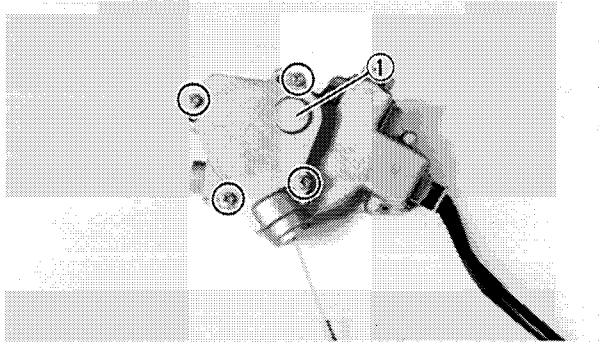

11. Remove:
- Cover (Carburetor switch – Left) ①
 - Throttle valve cable

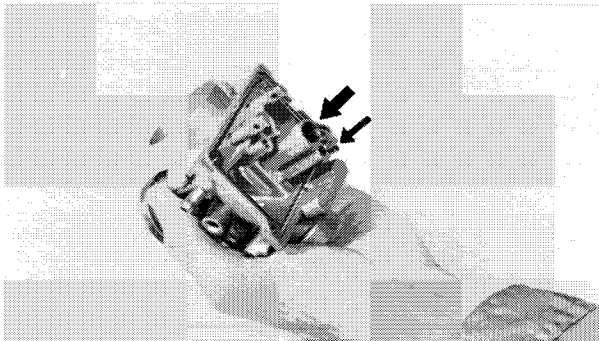

INSPECTION

1. Inspect:
- Carburetor body
Contamination → Clean.

NOTE: _____
Use a petroleum based solvent for cleaning.
Blow out all passages and jets with compressed air.

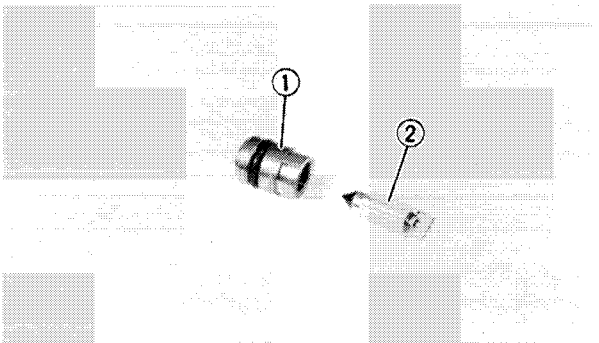

2. Inspect:
- Valve seat ①
 - Needle valve ②
Wear/Contamination → Replace.

NOTE: _____
Always replace the needle valve and valve seat as a set.

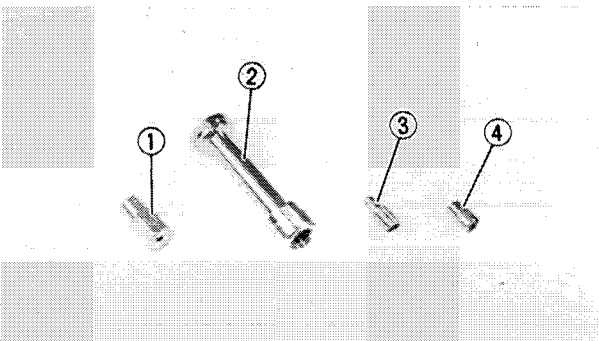

3. Inspect:
- Main jet ①
 - Main nozzle ②
 - Pilot jet ③
 - Starter jet ④
Wear → Replace.
Contamination/Clog → Clean.

NOTE: _____
Blow out the jets with compressed air.

5

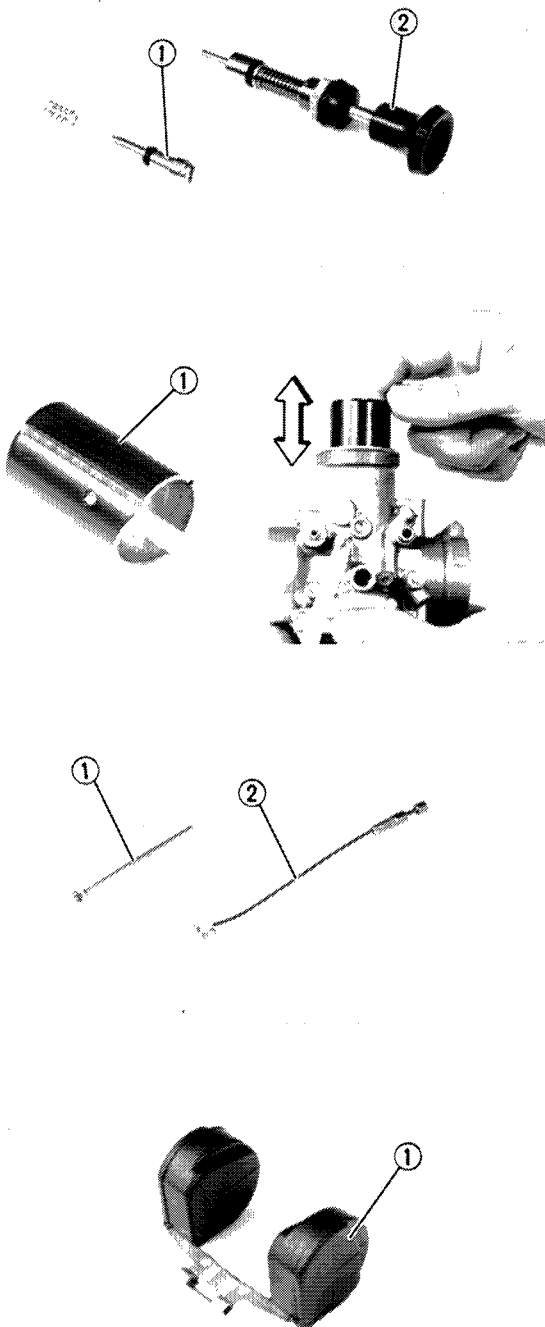

4. Inspect:

- Pilot air screw ①
- Starter plunger ②
Wear/Contamination → Replace.
- O-rings
Damage → Replace.

5. Inspect:

- Throttle valve ①
Wear/Damage → Replace.

6. Check:

- Free movement
Stick → Replace.
Insert the throttle valve into the carburetor body, and check for free movement.

7. Inspect:

- Jet needle ①
Bends/Wear → Replace.
- Throttle valve cable ②
Wear/Damage → Replace.
- Gasket
Damage → Replace.

8. Inspect:

- Float ①
Damage → Replace.

5

ASSEMBLY

Reverse the "DISASSEMBLY" procedure.
Note the following points.

⚠ CAUTION: _____
Before reassembling, wash all parts with a clean gasoline.

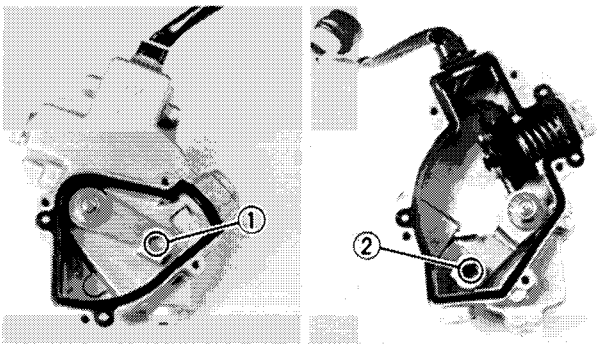

1. Apply:
 - Lithium base grease
 - Lightly grease to the cable pivot ① , ② .
2. Install:
 - Throttle cable
 - Throttle valve cable
 - Covers (Carburetor switch)

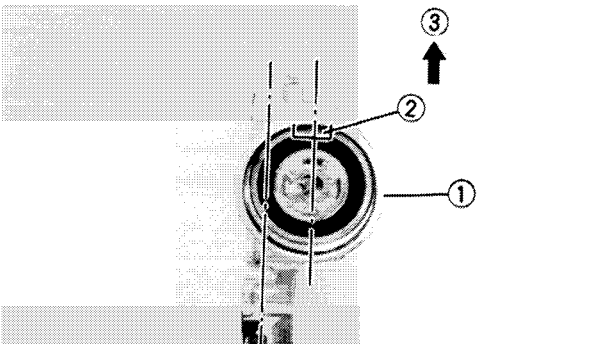

3. Install:
 - Washer
 - Carburetor top ①

NOTE: _____
 Install the carburetor top ① with its tab ② forward ③ .

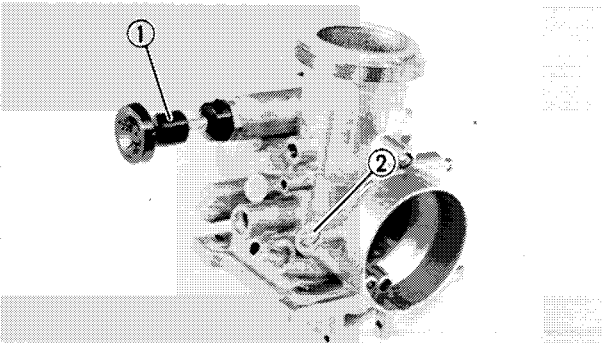

4. Install:
 - Starter plunger ①

	Starter Plunger: 3 Nm (0.3 m·kg, 2.2 ft·lb)
--	---

5. Adjust:
 - Pilot air screw ②

Pilot Air Screw: 1 and 1/2 turns out
--

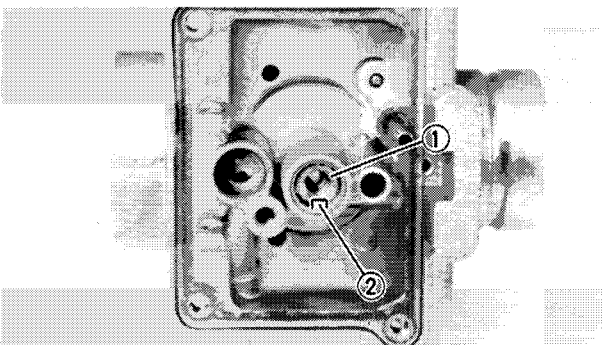

6. Install:
 - Starter jet
 - Pilot jet
 - Main nozzle ①
 - Main jet

NOTE: _____
 Be sure the pin ② engages with the locating slot on the main nozzle ① .

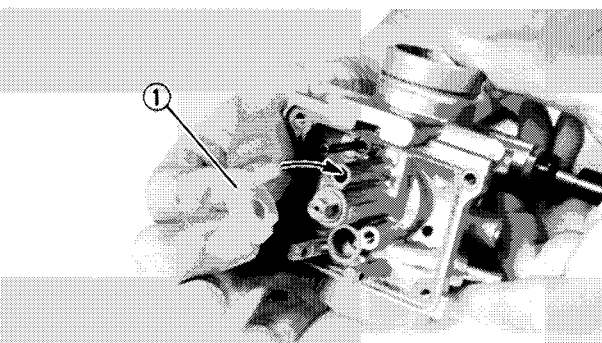

	Main Jet: 2 Nm (0.2 m·kg, 1.4 ft·lb)
--	--

7. Install:
 - Main jet ring ①

5



8. Install:
- Valve seat
 - Needle valve
 - Float
 - Float pin

 **Screw (Valve Seat Stopper):**
2 Nm (0.2 m·kg, 1.4 ft·lb)

9. Measure:
- Float height (a)
Out of specification → Adjust.

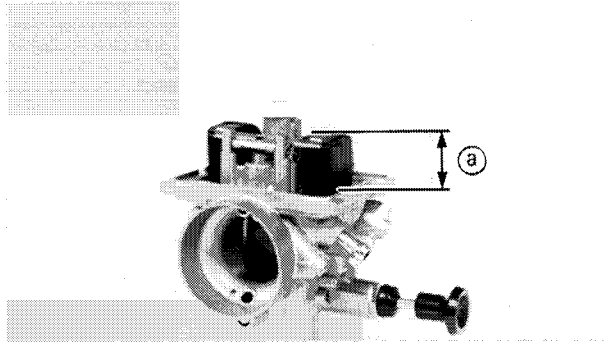

Float height measurement and adjustment steps:

- Hold the carburetor in an upside down position.
- Measure the distance between the mating surface of the float chamber (gasket removed) and top of the float using a gauge.

 **Float Height:**
20.0 ~ 21.5 mm (0.79 ~ 0.85 in)

NOTE: _____

The float arm should be resting on the needle valve, but not compressing the needle valve.

- If the float height is not within specification, inspect the valve seat and needle valve.
- If either is worn, replace them both.
- If both are fine, adjust the float height by bending the float tang ① on the float.
- Recheck the float height.

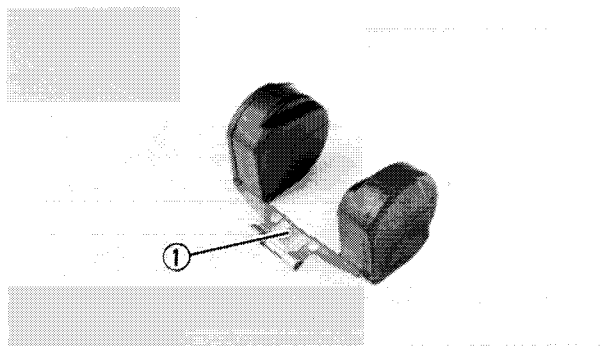

10. Install:
- Float chamber

 **Screw (Float Chamber):**
2 Nm (0.2 m·kg, 1.4 ft·lb)

INSTALLATION

Reverse the "REMOVAL" procedures.
Note the following points.

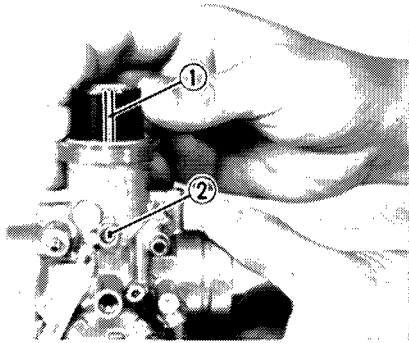

1. Install:
 - Throttle valve

NOTE: _____
Align the groove ① of the throttle valve with the projection ② of the carburetor body.

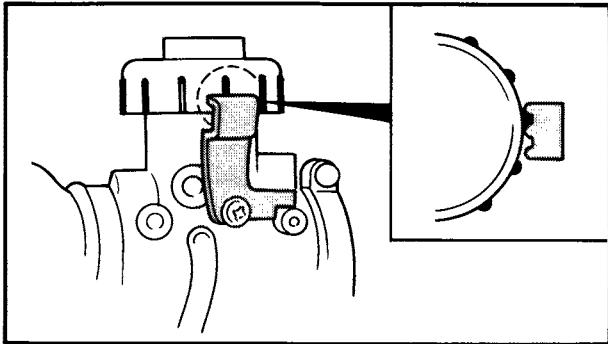

2. Install:
 - Stopper plate

NOTE: _____
Match one of the projections on the top cover with one of the two dents on the stopper plate.

CAUTION: _____

Tighten the top cover further to match as required, and never loosen.

5



Screw (Stopper Plate):
3 Nm (0.3 m·kg, 2.2 ft·lb)

3. Adjust:
 - Idle speed
Refer to the "IDLE SPEED ADJUSTMENT" section in the CHAPTER 3.



Idle Speed:
1,450 ~ 1,550 r/min

4. Adjust:
 - Throttle cable free play
Refer to the "THROTTLE CABLE FREE PLAY ADJUSTMENT" section in the CHAPTER 3.



Free Play:
4.0 ~ 6.0 mm (0.16 ~ 0.24 in)



FUEL LEVEL ADJUSTMENT

NOTE:

Before adjusting the fuel level, the float height should be adjusted.

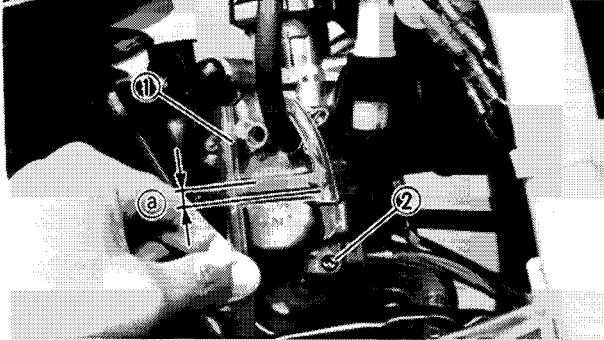

1. Measure:

- Fuel level
Out of specification → Adjust.

Fuel level measurement and adjustment steps:

- Place the machine on a level place.
- Attach the Fuel Level Gauge ① to the float chamber nozzle.



Fuel Level Gauge:
P/N YM-01312-A
P/N 90890-01312

- Loosen the drain screw ② and start the engine.
- Place tube vertically next to the center of the mating line of the mixing body and float chamber cover.
- Measure the fuel level ③ with gauge.



Fuel Level ③ :
0.5 ~ 1.5 mm (0.02 ~ 0.06 in)
Above the Carburetor Body Edge

- If the fuel level is incorrect, adjust the fuel level.
- Remove the carburetor.
- Inspect the valve seat and needle valve.
- If either is worn, replace them both.
- If both are fine, adjust the float height by bending the float tang ① on the float.
- Recheck the fuel level.

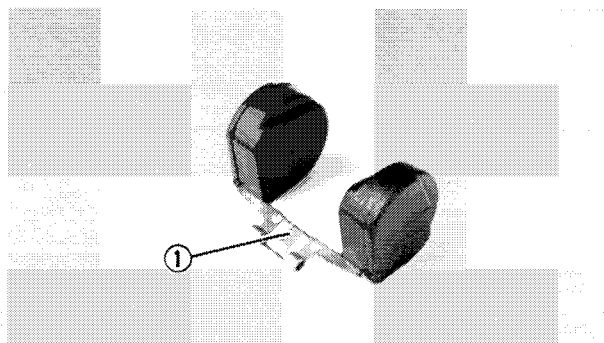



CARBURETOR SETTING CHANGE

In extremely cold weather, it is necessary to change carburetor setting to maintain optimum engine performance and to prevent engine damage.

1. Remove:
 - Carburetor assembly
Refer to "CARBURETOR – REMOVAL" section.
2. Adjust:
 - Carburetor setting

Carburetor setting chart		
Temperature	Main jet	Jet needle
0°C (32°F) above (STD)	#220	2nd groove
+5°C (41°F) ~ -15°C (5°F)	#230	2nd groove
-10°C (14°F) ~ -30°C (-22°F)	#230	3rd groove

① Main jet number

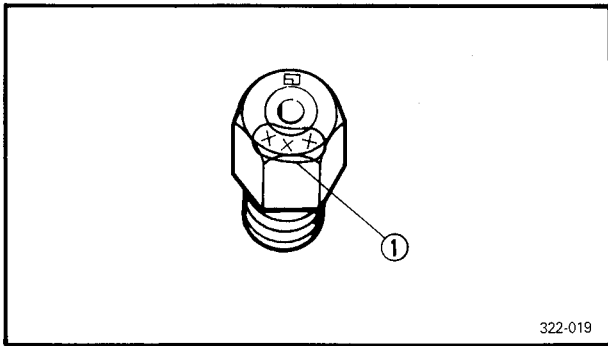

322-019

5

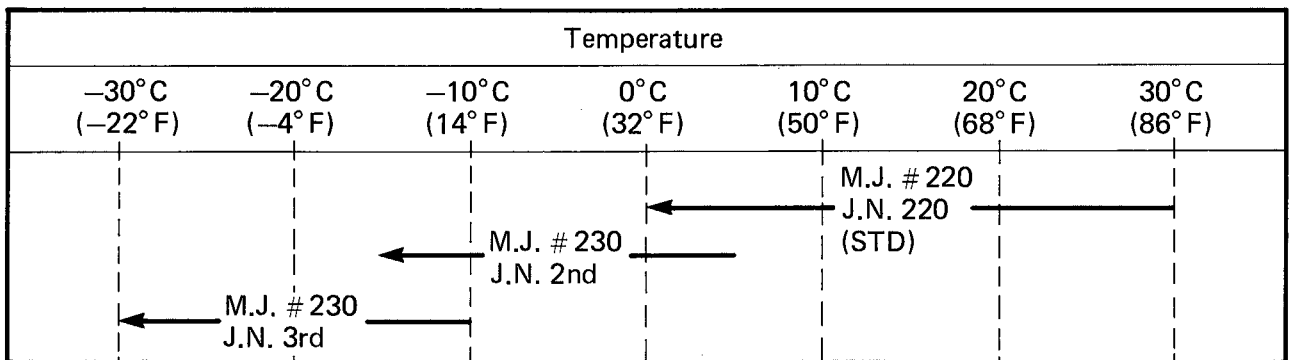

3. Install:
 - Carburetor assembly
Refer to "CARBURETOR – INSTALLATION" section.



REED VALVE

- ① Carburetor joint
- ② Reed valve assembly
- ③ Reed valve
- ④ Gasket
- ⑤ Stopper plate

A	Reed Valve Stopper Height: 8.3 ~ 8.7 mm (0.33 ~ 0.34 in)
B	Reed Valve Bending Limit: 0.5 mm (0.02 in)

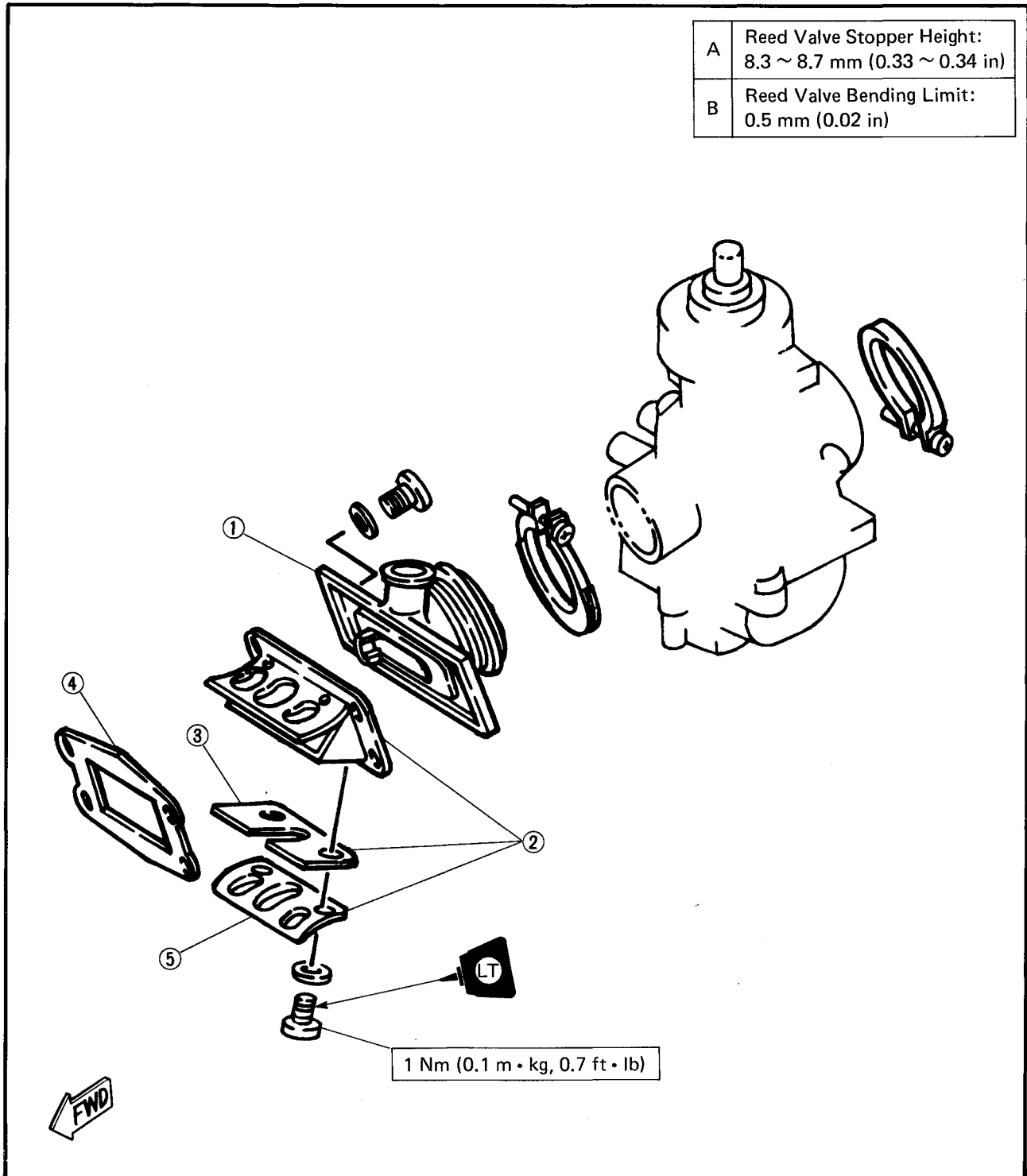

5



REMOVAL

1. Remove:

- Carburetor

Refer to "CARBURETOR – REMOVAL" section.

2. Remove:

- Carburetor joint ①
- Reed valve assembly ②
- Gasket ③

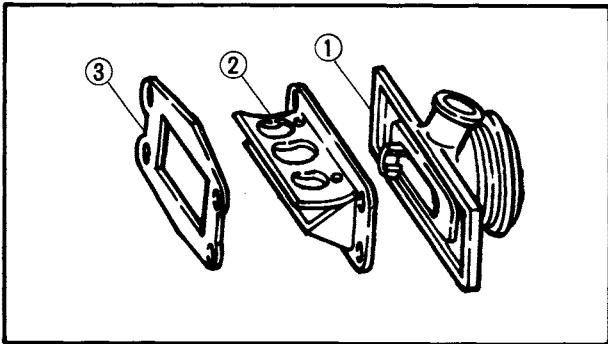

DISASSEMBLY

1. Remove:

- Stopper plate ①
- Reed valve ②

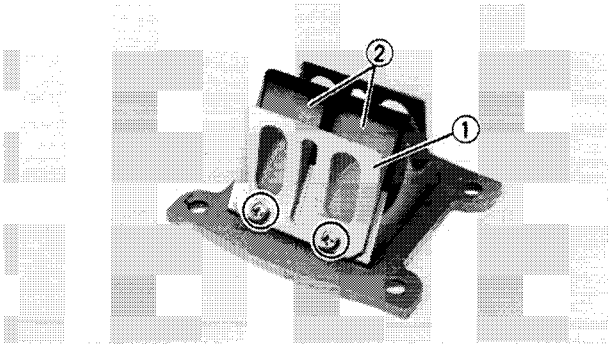

5

INSPECTION

1. Inspect:

- Rubber joint
Weathering/Other deterioration → Replace.
- Reed petals
Fatigue/Cracks → Replace.

Inspection steps:

- Visually inspect the reed petals.

NOTE:

Correct reed petals should fit flush or nearly flush against neoprene seats.

- If in doubt as to sealing ability, apply suction to carburetor side of assembly.
- Leakage should be slight to moderate.

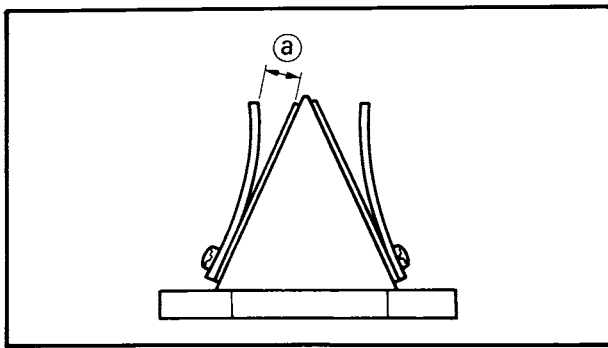

2. Measure:

- Valve stopper height (a)
Out of specification → Adjust stopper/
Replace valve stopper.



Valve Stopper Height:
8.3 ~ 8.7 mm (0.33 ~ 0.34 in)

NOTE:

If it is 0.4 mm (0.016 in) more or less than specified, replace the valve stopper.

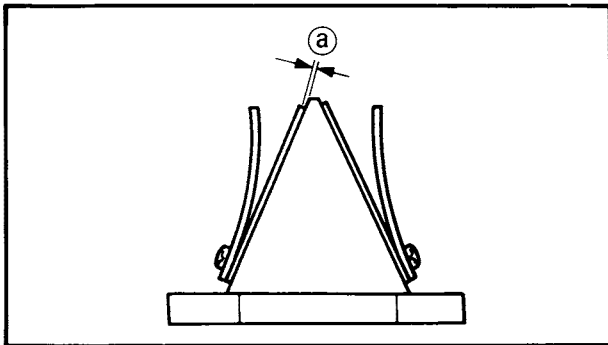

3. Measure:

- Reed valve bending limit (a)
Out of specification → Replace.



Reed Valve Bending Limit:
0.5 mm (0.02 in)

5

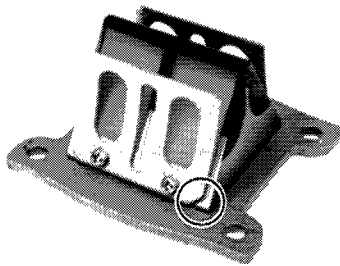

ASSEMBLY

When assembling the reed valve, reverse the disassembly procedure. Note the following points.

1. Install:

- Reed valve
- Reed valve stopper

NOTE:

Note the cut in the lower corner of the reed and stopper plate.

2. Tighten:

- Screws (Reed valve)



Screws (Reed Valve):
1 Nm (0.1 m·kg, 0.7 ft·lb)
LOCTITE®

NOTE:

Tighten each screw gradually to avoid warping.

**INSTALLATION**

When installing the reed valve, reverse the removal procedure. Note the following points.

1. Install:
 - Gasket (New)
2. Tighten:
 - Bolts (Carburetor joint)



Bolts (Carburetor Joint):
8 Nm (0.8 m·kg, 5.8 ft·lb)

NOTE:

Tighten each bolt gradually to avoid warping.

CHASSIS

FRONT WHEEL AND FRONT BRAKE

- ① Cam lever
- ② Wear indicator plate
- ③ Brake shoe plate
- ④ Oil seal
- ⑤ O-ring
- ⑥ Camshaft
- ⑦ Spring
- ⑧ Brake shoe
- ⑨ Bearing
- ⑩ Spacer collar
- ⑪ Wheel hub
- ⑫ Collar
- ⑬ Plain washer
- ⑭ Cotter pin

TIRE AIR PRESSURE		
COLD TIRE PRESSURE	FRONT	REAR
STANDARD	30 kPa (0.30 kg/cm ² , 4.3 psi)	25 kPa (0.25 kg/cm ² , 3.6 psi)
MINIMUM	27 kPa (0.27 kg/cm ² , 3.8 psi)	22 kPa (0.22 kg/cm ² , 3.1 psi)
MAXIMUM	33 kPa (0.33 kg/cm ² , 4.7 psi)	28 kPa (0.28 kg/cm ² , 4.0 psi)

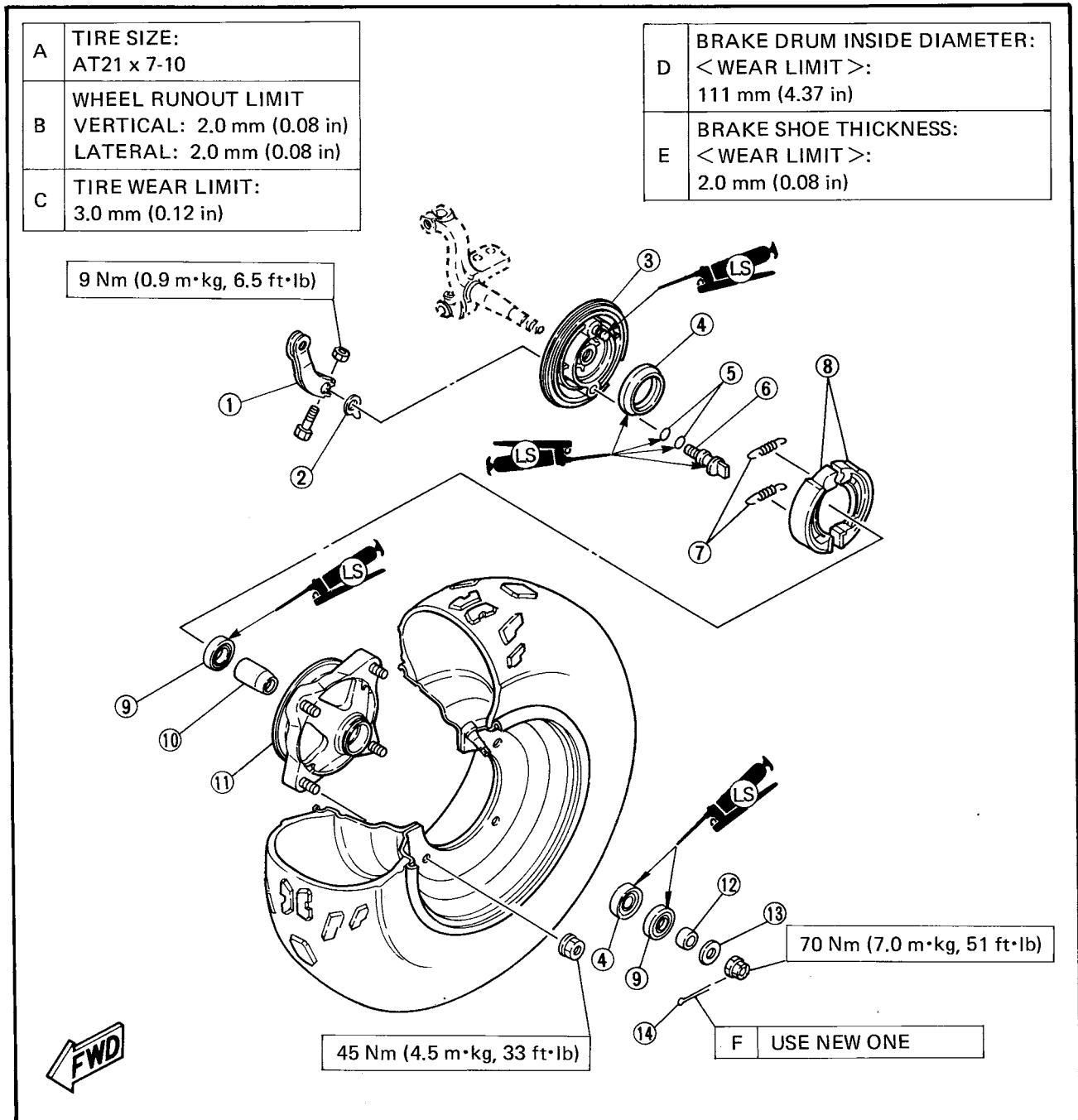

6

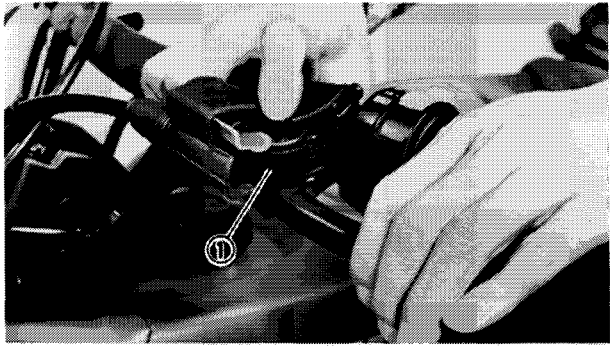

REMOVAL

1. Place the machine on a level place.
2. Loosen:
 - Nuts (Front wheel)
 Apply the parking brake ①.
3. Elevate the front wheels by placing the suitable stand under the frame.

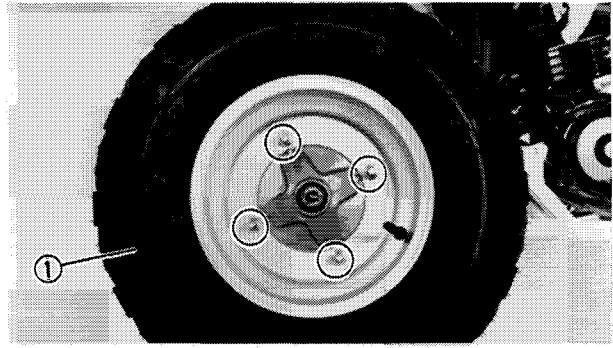

4. Remove:
 - Nuts (Front wheel)
 - Front wheel ①

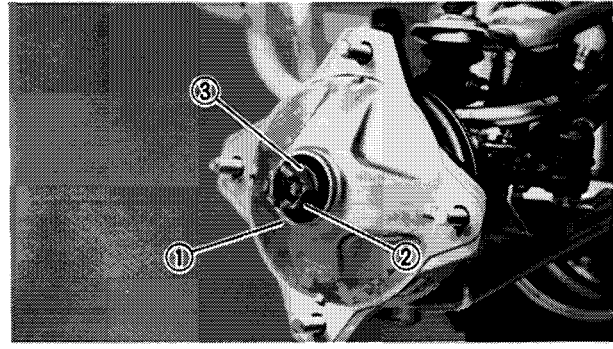

5. Remove:
 - Cotter pin ①
 - Nut ② (Wheel hub)
 - Plain washer ③

6

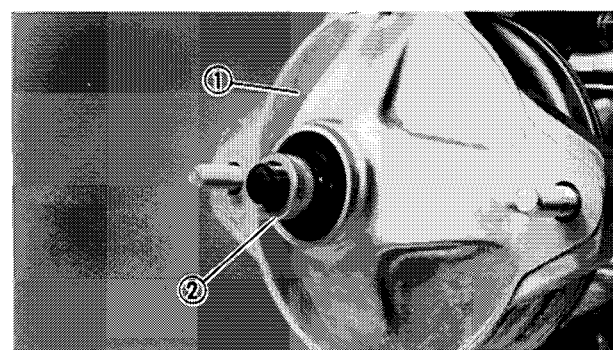

6. Remove:
 - Wheel hub ① (Front)
 - Collar ②

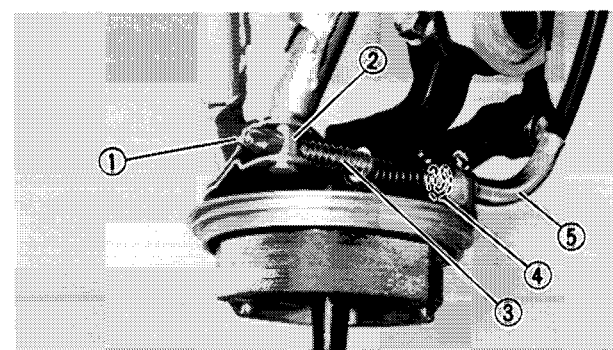

7. Remove:
 - Adjuster ①
 - Pin ②
 - Spring ③
 - Circlip ④
 - Brake cable ⑤
(from brake shoe plate)

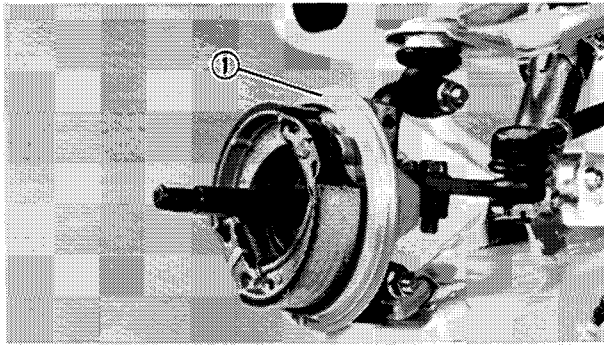

8. Remove:
 • Brake shoe plate ①

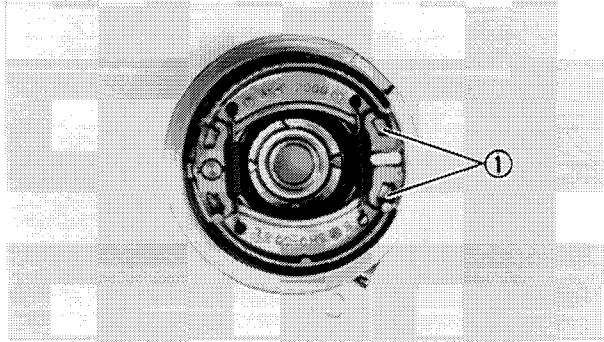

9. Remove:
 • Brake shoes ①

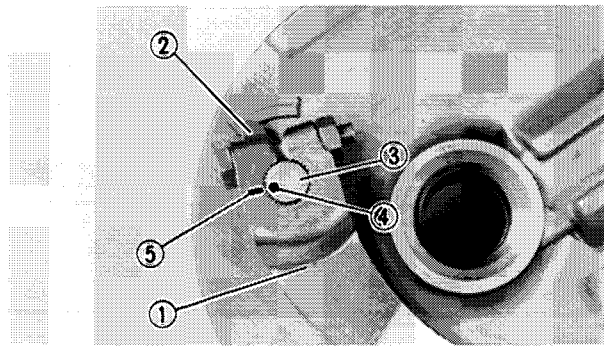

10. Remove:
 • Brake cam lever ①
 • Wear indicator plate ②
 • Camshaft ③

NOTE: _____
 Place an aligning mark ④ next to the punched mark ⑤ on the camshaft lever before removal so that it can be reinstalled in the original position, which means that the punched mark will be on the line perpendicular to the cut-out of the cam lever.

INSPECTION

1. Inspect:
 • Wheel
 Cracks/Bends/Warpage → Replace.

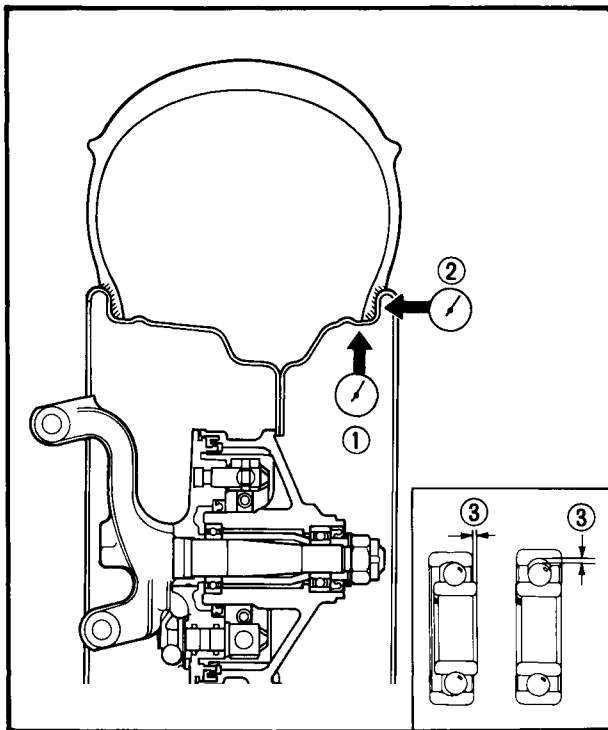

2. Measure:

- Wheel runout
 - Over specified limit → Replace wheel or check bearing play ③ .



Rim Runout Limits:
 Radial ① : 2.0 mm (0.08 in)
 Lateral ② : 2.0 mm (0.08 in)

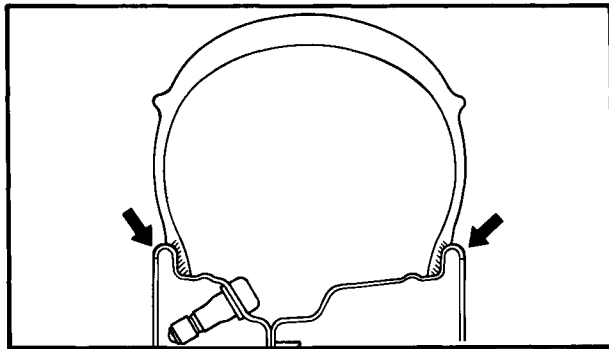

⚠ WARNING:

After replacing the tire, ride conservatively to allow the tire to be properly seated in the rim. Failure to do so may cause an accident resulting in machine damage and possible operator injury.

6

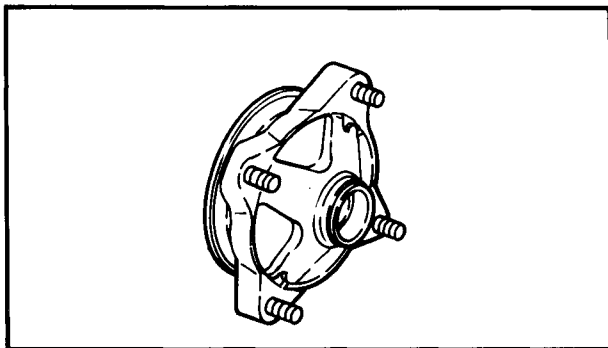

3. Inspect:

- Front wheel hub
 - Cracks/Damage → Replace.

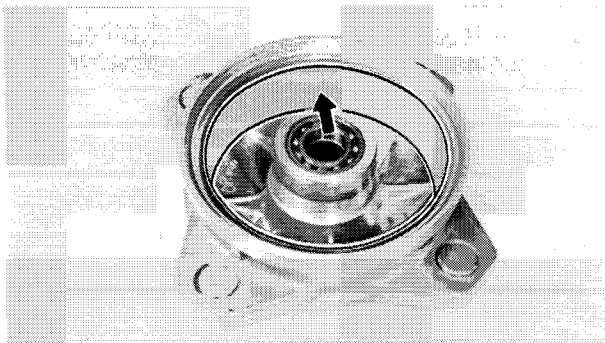

4. Inspect:

- Brake drum (Inner surface)
 - Oil → Wipe off brake drum with rag soaked in lacquer thinner or solvent.
 - Scratches → Polish brake drum lightly and evenly with emery cloth.

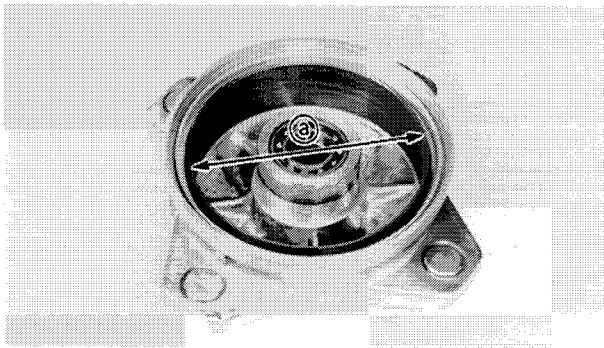

5. Measure:

- Brake drum inside diameter (a)
Out of specification → Replace.



Brake Drum Inside Diameter:
110 mm (4.33 in)
< Wear Limit >:
111 mm (4.37 in)

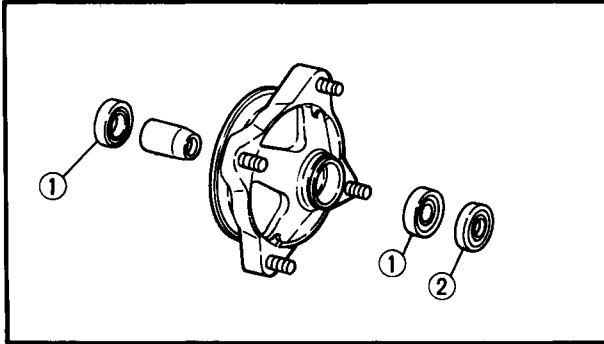

6. Inspect:

- Bearings (1) (Front wheel hub)
Bearings allow play in the wheel hub or the wheel turns roughly → Replace.
- Oil seal (2)
Wear/Damage → Replace.

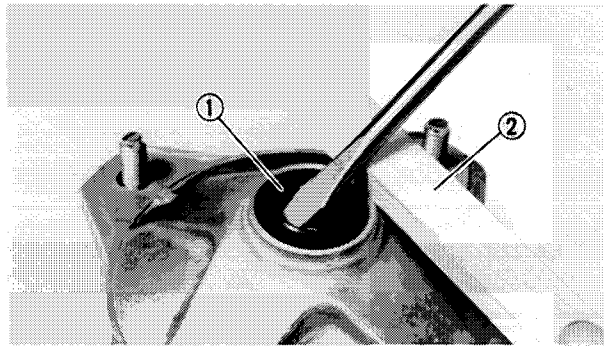

Wheel bearing and oil seal replacement steps:

- Clean the outside of the wheel hub.
- Remove the oil seal (1) use a flat-head screw driver.

NOTE: _____
Place a wood block (2) against the outer edge to protect this edge.

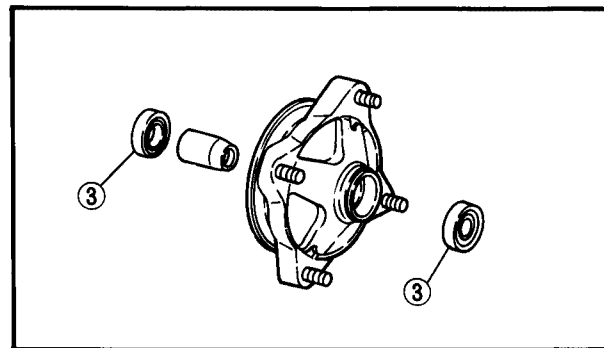

- Remove the bearing (3) using a general bearing puller.
- Install the new bearing and oil seal by reversing the previous steps.

NOTE: _____
Use a socket (4) that matches the outside diameter of the race of the bearing and oil seal.

CAUTION: _____

Do not strike the center race (5) or balls (6) of the bearing. Contact should be made only with the outer race (7).

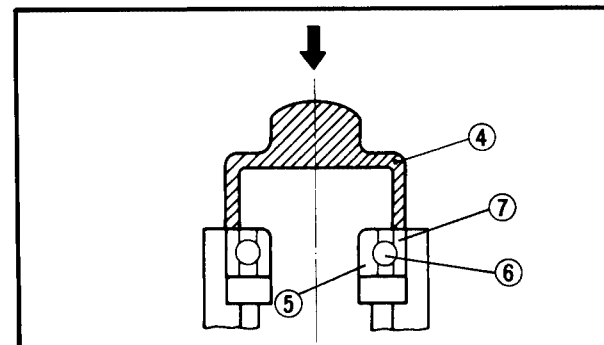

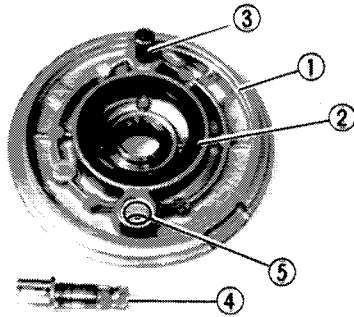
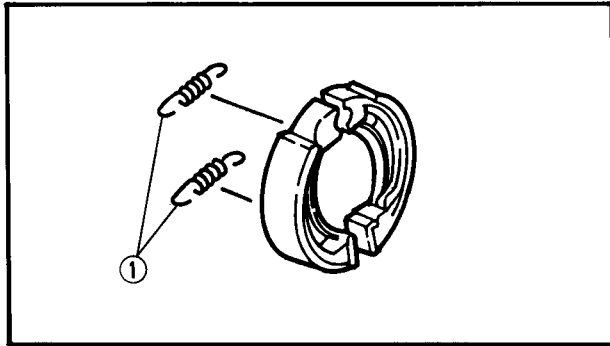
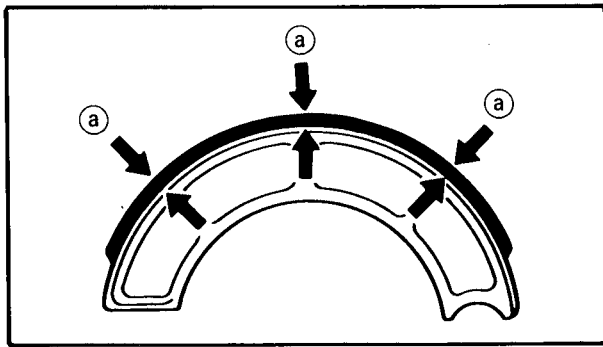

7. Inspect:
- Brake shoes
Glazed parts → Sand with coarse sand-paper.
8. Measure:
- Brake shoe thickness **a**
Out of specification → Replace.

	Brake Shoe Thickness:
	4.0 mm (0.16 in)
	< Wear Limit > : 2.0 mm (0.08 in)

9. Inspect:
- Shoe springs **1**
Wear/Damage → Replace.

10. Inspect:
- Brake shoe plate **1**
Cracks/Damage → Replace.
 - Oil seal **2**
 - Brake shoe pivot pin **3**
Wear/Damage → Replace.
 - Camshaft **4**
 - Camshaft hole **5**
Scratches/Excessive wear → Replace.

INSTALLATION

Reverse the "REMOVAL" procedures.
Note the following points.

1. Lubricate:
- Brake camshaft **1**
 - Brake shoe pivot pin **2**
 - Oil seal **3** (Brake shoe plate)

	Lightweight Lithium-soap
	Base Grease

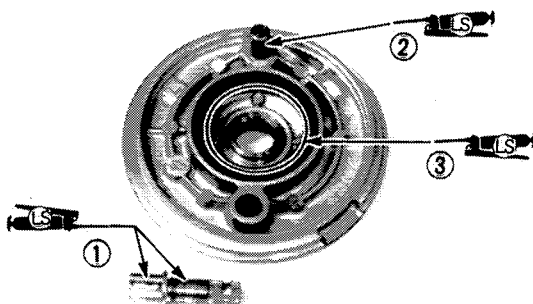

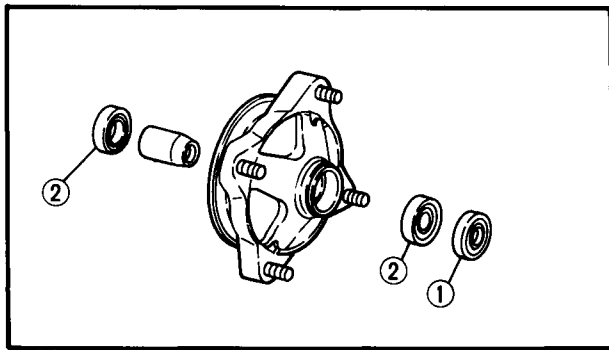

2. Lubricate:

- Oil seal lips ① (Front wheel hub)
- Bearings ② (Front wheel hub)

 **Lightweight Lithium-soap Base Grease (Lightly)**

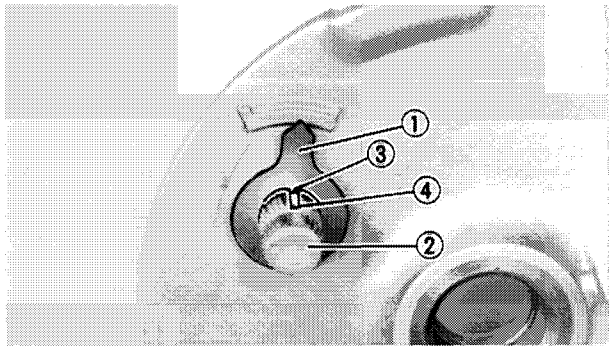

3. When installing the wear indicator plate ① to the camshaft ② align the projection ③ on the wear indicator plate with the slot ④ on the camshaft.

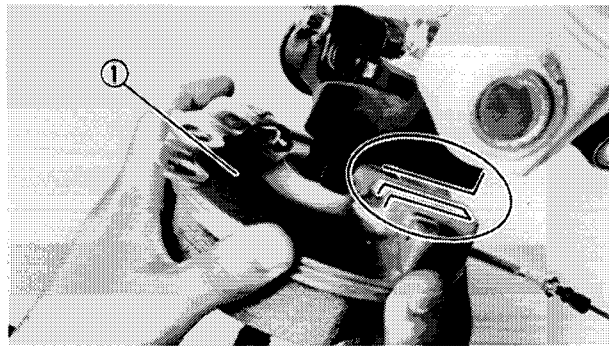

4. Install:

- Brake shoe plate ①

NOTE:

Be sure the boss on the knuckle correctly engages with the locating slot on the brake shoe plate.

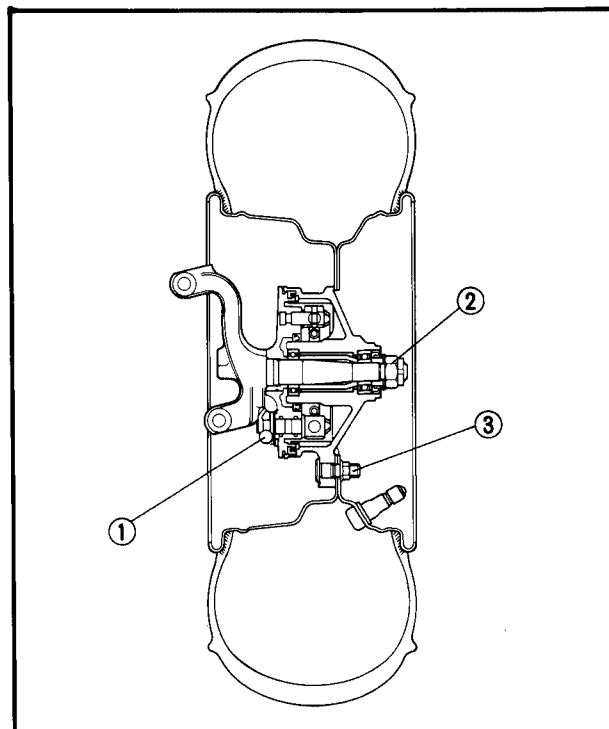

5. Tighten:

- Bolt ① (Brake cam lever)
- Nut ② (Front wheel hub)
- Nuts ③ (Front wheel)

 **Bolt (Brake Cam Lever):**
9 Nm (0.9 m·kg, 6.5 ft·lb)
Nut (Front Wheel Hub):
70 Nm (7.0 m·kg, 51 ft·lb)
Nut (Front Wheel):
45 Nm (4.5 m·kg, 33 ft·lb)

NOTE:

Thoroughly wipe off the excess grease.

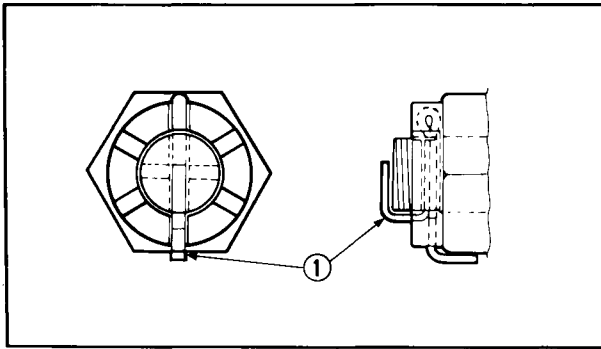

6. Install:
- Cotter pin ① (New)

NOTE: _____
 Do not loosen the wheel hub nut after torque tightening. If the wheel hub nut groove is not aligned with the cotter pin hole, align groove with the hole by tightening up on the wheel hub nut.

⚠ WARNING: _____
 Always use a new cotter pin.

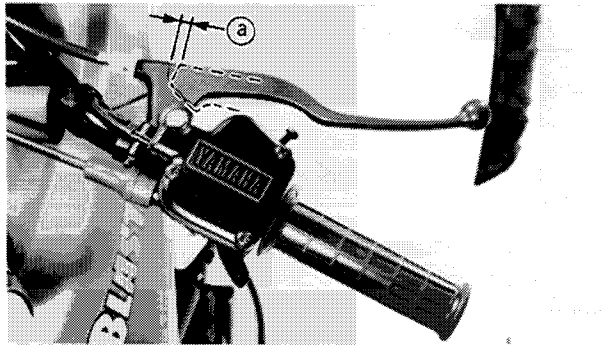

7. Adjust:
- Front brake cable free play ②
 Refer to the "FRONT BRAKE ADJUSTMENT" section in the CHAPTER 3.

 **Brake Cable Free Play:**
 5 ~ 8 mm (0.20 ~ 0.31 in)

6

REAR WHEEL AND REAR AXLE

- ① Rear axle
- ② Oil seal
- ③ Bearing
- ④ Spacer
- ⑤ Rear axle hub
- ⑥ Inner collar
- ⑦ Driven sprocket hub
- ⑧ Driven sprocket
- ⑨ Chain tensioner
- ⑩ Lock washer
- ⑪ Drive chain
- ⑫ Rear axle nut (Inner)
- ⑬ Rear axle nut (Outer)
- ⑭ Rear wheel hub
- ⑮ Cotter pin

*Rear Axle Nut Tightening Steps:

Apply locking agent (LOCTITE®) to rear axle nuts threads.

1st: Tighten the inner rear axle nut.
55 Nm (5.5 m•kg, 40 ft•lb)

2nd: Tighten the outer rear axle nut while holding the inner rear axle nut.
190 Nm (19.0 m•kg, 140 ft•lb)

3rd: Loosen the inner rear axle nut while holding the outer rear axle nut.
240 Nm (24.0 m•kg, 170 ft•lb)

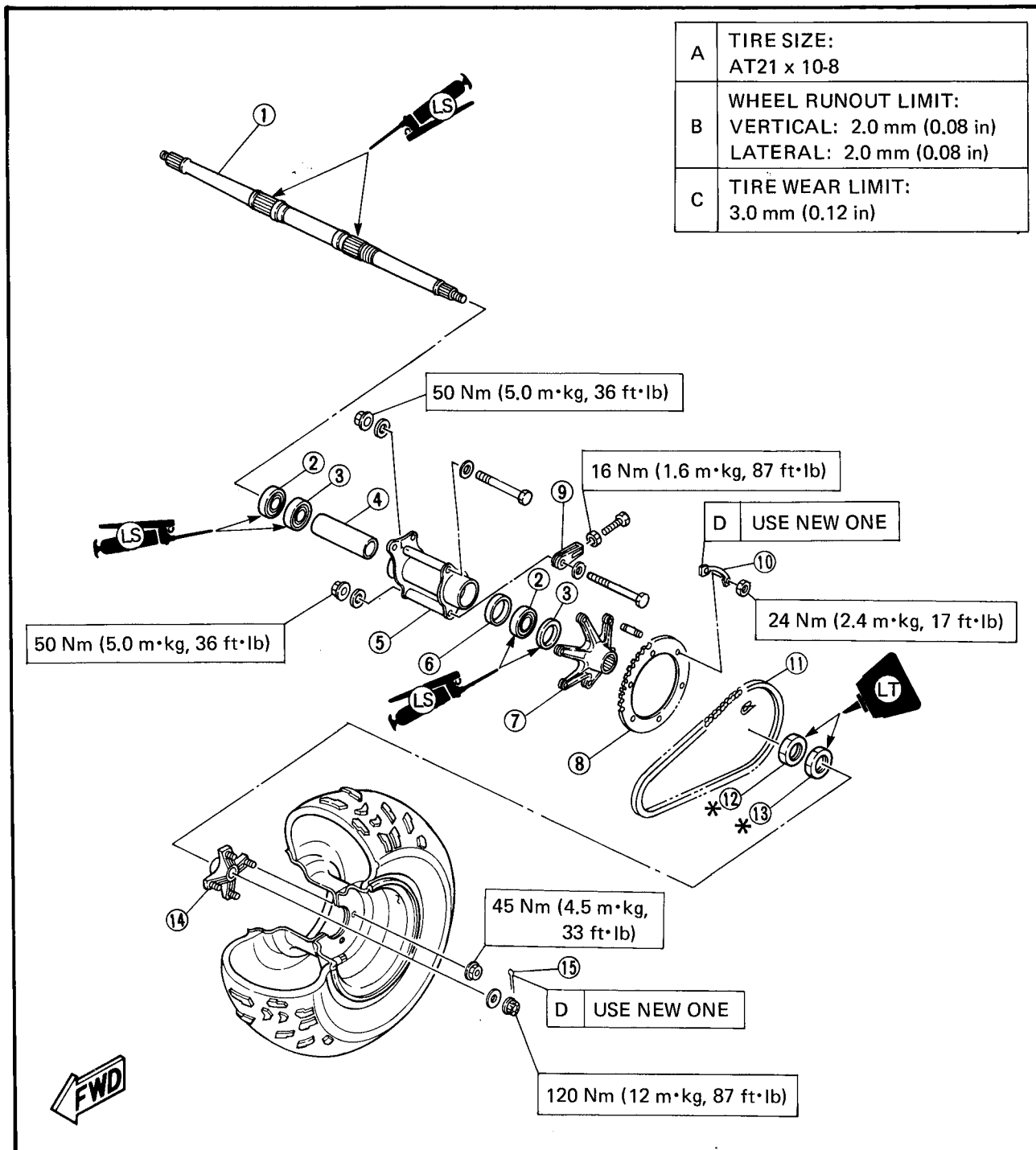

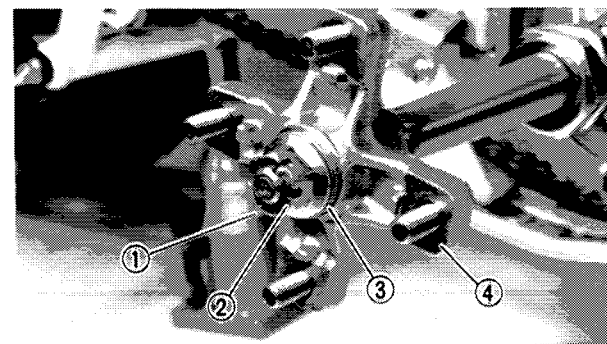
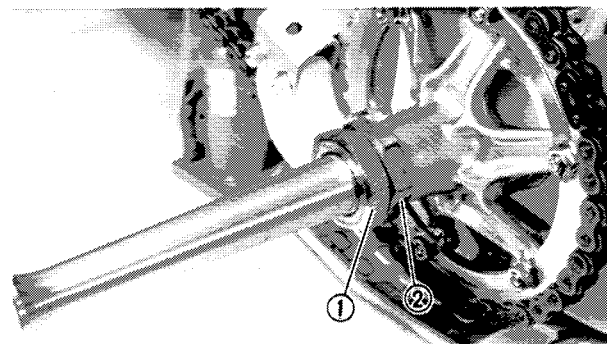
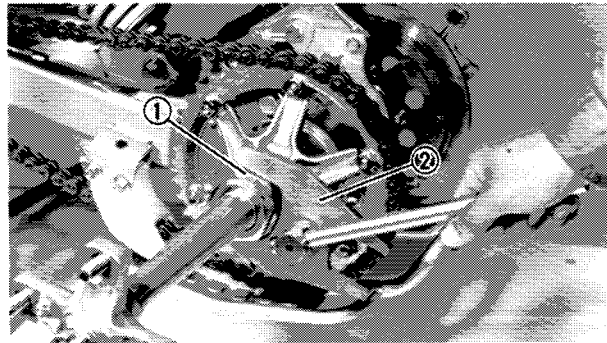
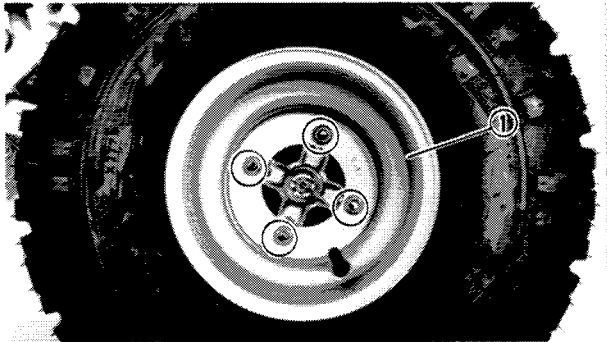
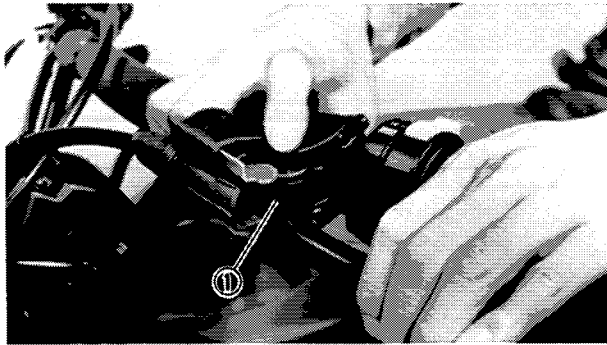

REMOVAL

1. Place the machine on a level place.
2. Apply the parking brake ① .

3. Loosen:
 - Nuts (Rear wheel)
4. Elevate the rear wheels by placing the suitable stand under the rear of frame.
5. Remove:
 - Rear wheels ①

6. Tighten:
 - Nut ① (Rear axle – Inner)

Give 1/8 clockwise turn using the nut wrench ② .

	<p>Nut Wrench: P/N. YM-37132 P/N. 90890-01419</p>
---	--

7. Loosen:
 - Nut ① (Rear axle – Outer)
 - Nut ② (Rear axle – Inner)

Use the Nut Wrench.

	<p>Nut Wrench: P/N. YM-37132 P/N. 90890-01419</p>
---	--

8. Remove:
 - Cotter pin ①
 - Nut ② (Wheel hub)
 - Plate washer ③
 - Wheel hub ④

6

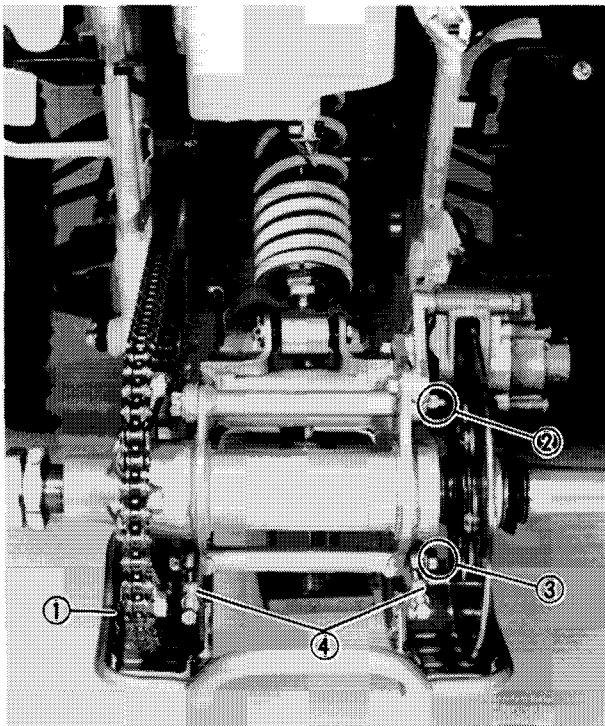

9. Remove:
 - Under guard ①
10. Loosen:
 - Nut ② (Rear axle hub – Upper)
 - Nut ③ (Rear axle hub – Lower)
11. Loosen:
 - Adjusters ④ (Chain tensioner)

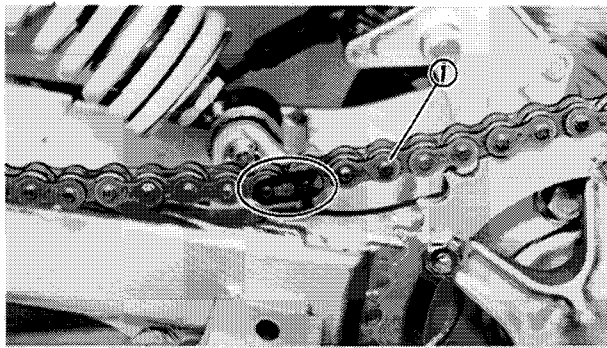

12. Remove:
 - Drive chain assembly ①
 Refer to the "DRIVE CHAIN AND SPROCKET – REMOVAL" section.

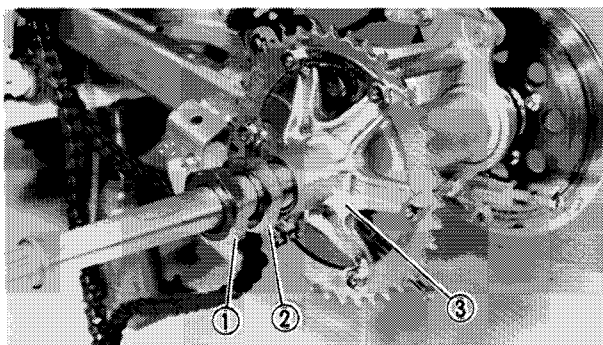

13. Remove:
 - Nut ① (Rear axle – Outer)
 - Nut ② (Rear axle – Inner)
 - Sprocket hub ③ (Driven sprocket)

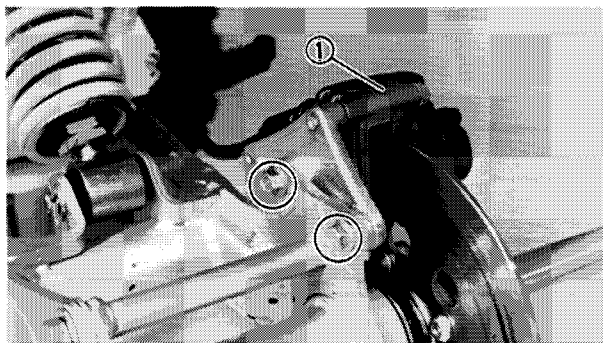

14. Release the parking brake.
15. Remove:
 - Brake caliper assembly ① (Rear)

NOTE: _____
 Do not depress the parking brake lever and brake pedal when the brake caliper is off the disc otherwise the brake pads will be forced shut.

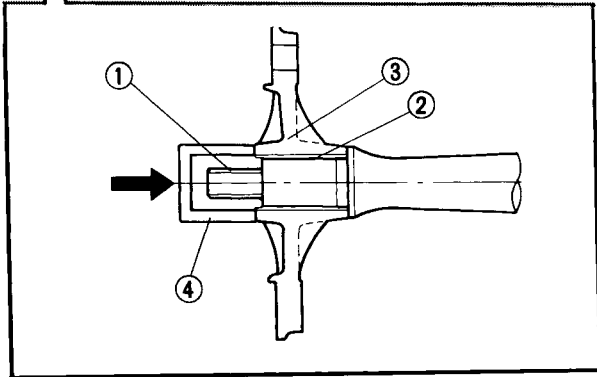
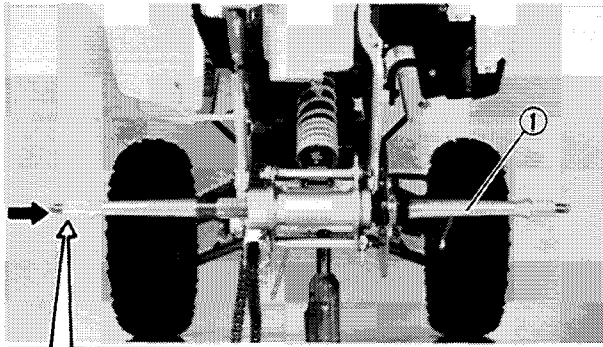

16. Remove:
- Rear axle ①
(from right side)

CAUTION:

- Never directly tap the axle end with a hammer, this will result in damage to the axle thread ① and spline ②.
- Install the wheel boss ③ and suitable socket ④ on the axle end to protect the thread and spline from damage.

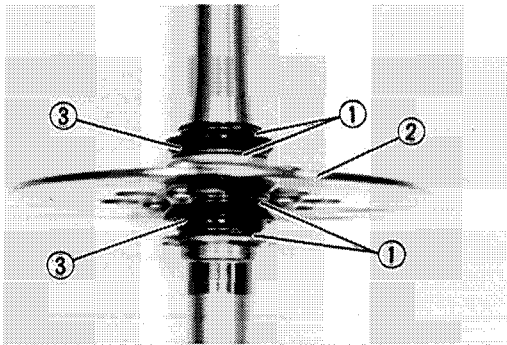

17. Remove:
- Wire clips ①
 - Disc hub ② (Brake disc)

CAUTION:

Remove the wire clip with strict attention paid not to damage the disc hub cover ③.

6

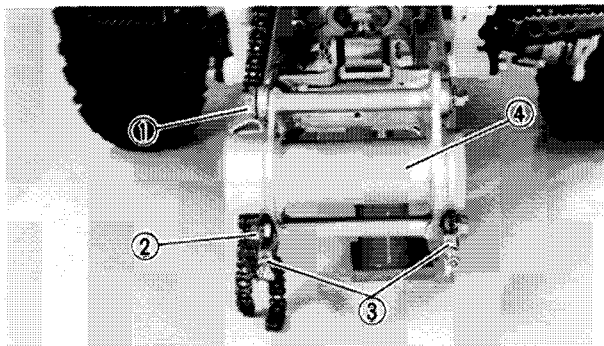

18. Remove:
- Bolt ① (Rear axle hub – Upper)
 - Bolt ② (Rear axle hub – Lower)
 - Chain tensioner assembly ③
 - Rear axle hub ④

INSPECTION

1. Inspect:
 - Wheel
Refer to the "WHEEL INSPECTION" section in the CHAPTER 3.
2. Measure:
 - Wheel runout
Refer to the "FRONT WHEEL AND FRONT BRAKE – INSPECTION" section.

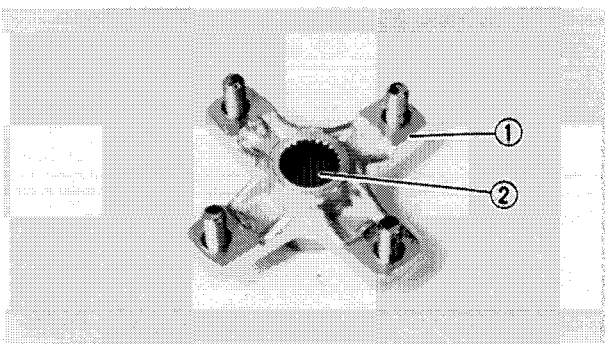

3. Inspect:
- Wheel hub ①
Cracks/Damage → Replace.
 - Splines ② (Wheel hub)
Wear/Damage → Replace.

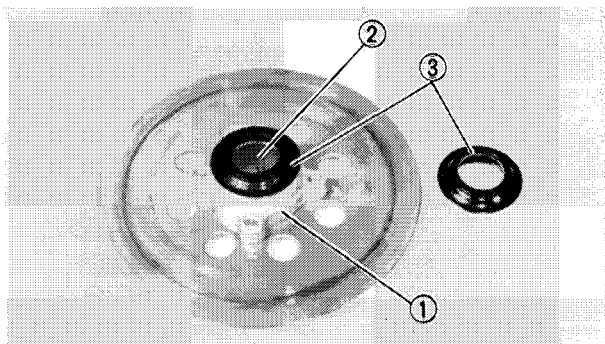

4. Inspect:
- Disc hub ①
Cracks/Damage → Replace.
 - Splines ② (Disk hub)
Wear/Damage → Replace.
 - Disc hub cover ③
Wear/Damage → Replace.

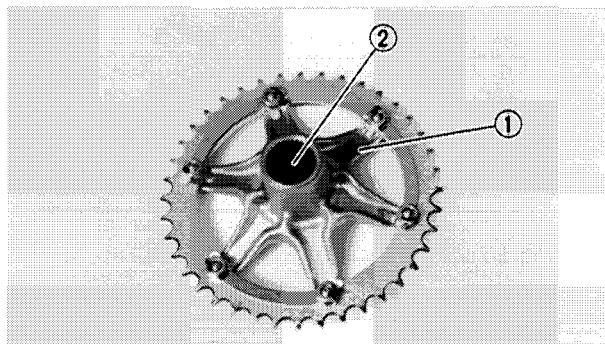

5. Inspect:
- Sprocket hub ①
Cracks/Damage → Replace.
 - Splines ② (Sprocket hub)
Wear/Damage → Replace.

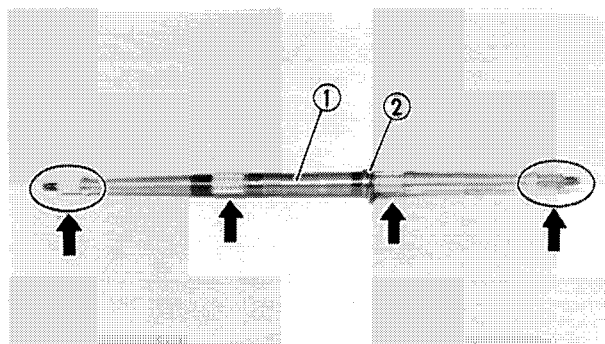

6. Inspect:
- Rear axle ①
Scratched (Excessively)/Damage → Replace.
 - Splines/Threads (Rear axle)
Wear/Damage → Replace.
 - Dust cover ② (Oil seal)
Damage → Replace.

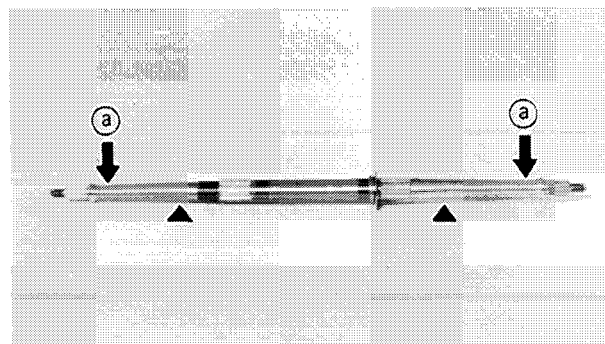

7. Measure:
- Rear axle runout ①
Out of specification → Replace.

 **Rear Axle Runout Limit:**
1.5 mm (0.06 in)

⚠ WARNING:

Do not attempt to straighten a bent axle.

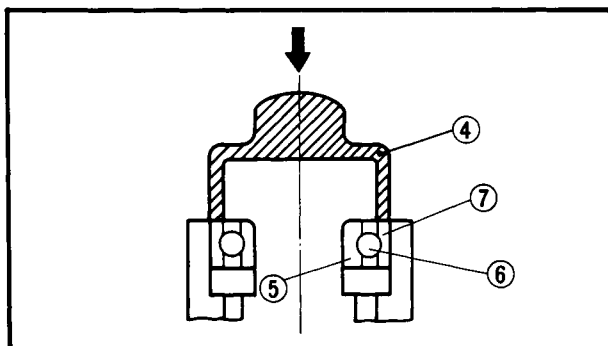
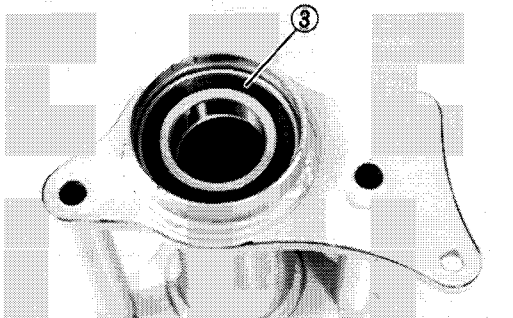
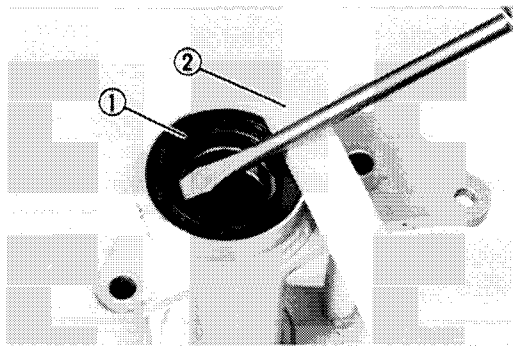
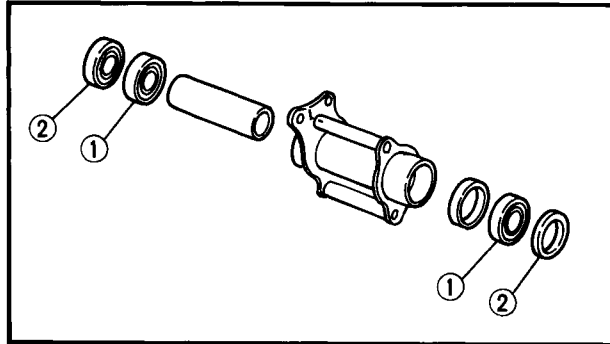
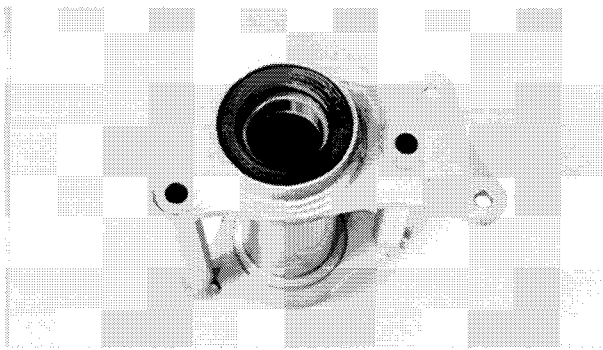

8. Inspect:

- Rear axle hub
Cracks/Bend/Damage → Replace.

9. Inspect:

- Bearings ① (Rear axle hub)
Bearings allow play in the axle hub or the bearing turns roughly → Replace.
- Oil seals ②
Wear/Damage → Replace.

Rear axle hub bearing and oil seal replacement steps:

- Clean the outside of the rear axle.
- Remove the oil seal ① use a flat-head screw driver.

NOTE:

Place a wood block ② against the outer edge to protect this edge.

- Remove the bearing ③ using a general bearing puller.
- Install the new bearings and oils seal by reversing the previous steps.

NOTE:

Use a socket ④ that matches the outside diameter of the race of the bearing and oil seal.

CAUTION:

Do not strike the center race ⑤ or balls ⑥ of the bearing. Contact should be made only with the outer race ⑦.

6

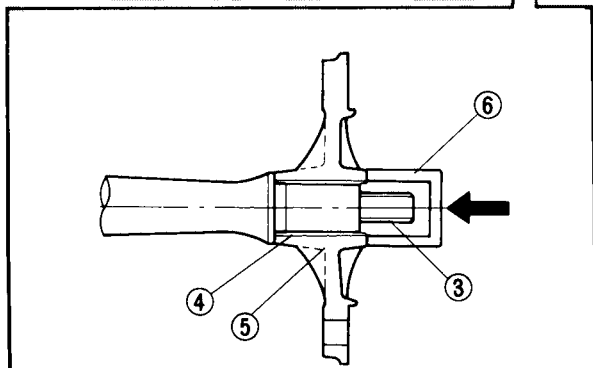
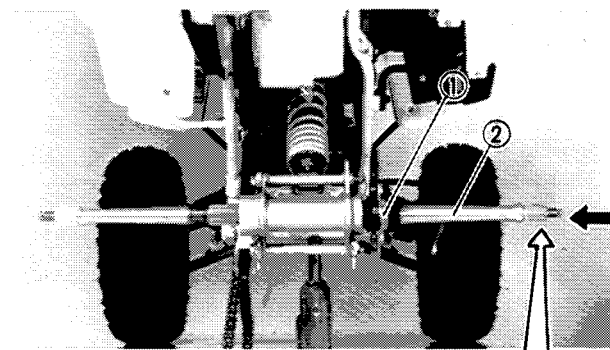
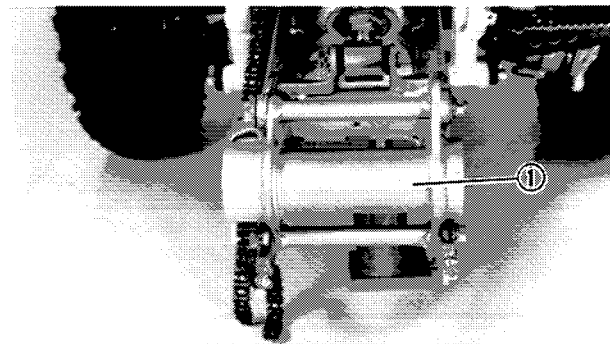
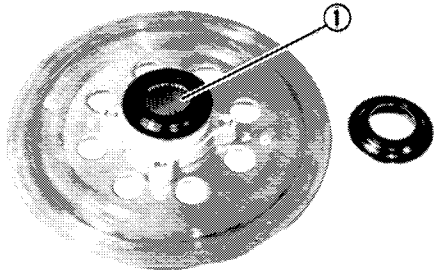
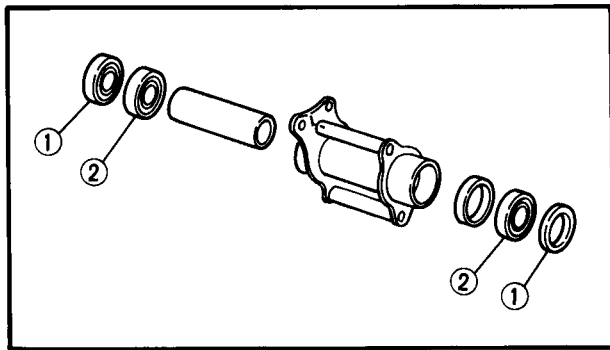

INSTALLATION

Reverse the "REMOVAL" procedures.
Note the following points.

1. Lubricate:

- Oil seal lips ① (Rear axle hub)
- Bearings ② (Rear axle hub)



**Lightweight Lithium-soap
Base Grease (Lightly)**

2. Lubricate:

- Splines ① (Brake disk hub)



**Lightweight Lithium-soap
Base Grease**

3. Install:

- Rear axle hub ①

NOTE:

At this time, the rear axle hub should not be tightened completely. Final tightening is done after the chain slack adjustment.

4. Install:

- Disc hub ① (Brake disc)
(to rear axle)
- Rear axle ②
Tap the RIGHT END axle.

CAUTION:

- Never directly tap the axle end with a hammer, this will result in damage to the axle thread ③ and spline ④.
- Install the wheel boss ⑤ and suitable socket ⑥ on the axle end to protect the thread and spline from damage.

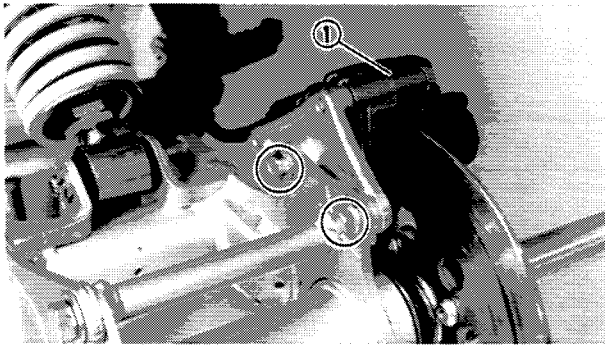

5. Install:
- Brake caliper assembly ① (Rear)

	Bolt (Brake Caliper Assembly): 28 Nm (2.8 m·kg, 20 ft·lb)
---	---

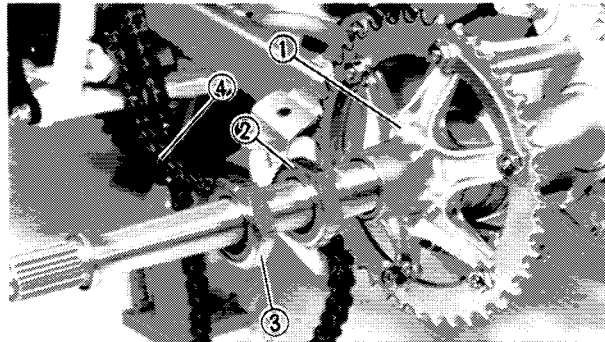

6. Install:
- Sprocket hub ① (Driven sprocket)
 - Nut ② (Rear axle – Inner)
 - Nut ③ (Rear axle – Outer)
 - Drive chain ④

NOTE: _____
At this time, the rear axle nuts should not be screwed on.

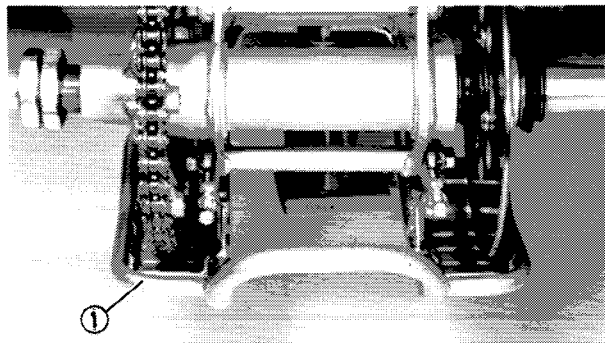

7. Install:
- Under guard ①

	Bolt (Under Guard): 23 Nm (2.3 m·kg, 17 ft·lb)
---	--

6

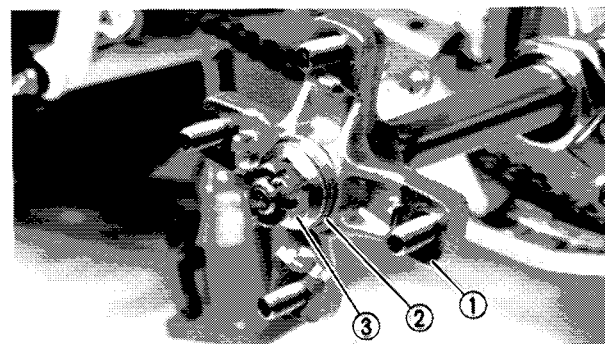

8. Apply the parking brake.
9. Install:
- Wheel hub ①
 - Plate washer ②
 - Nut ③ (Wheel hub)

	Nut (Wheel Hub): 120 Nm (12 m·kg, 87 ft·lb)
---	---

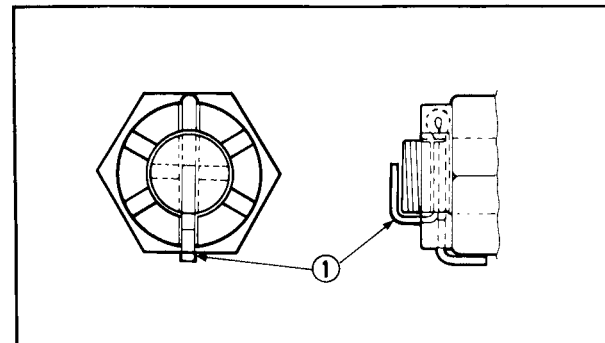

10. Install:
- Cotter pins (New) ①

NOTE: _____
Do not loosen the axle nut after torque tightening. If the axle nut groove is not aligned with the cotter pin hole, align groove with the hole by tightening up on the axle nut.

⚠ WARNING: _____
Always use a new cotter pin.

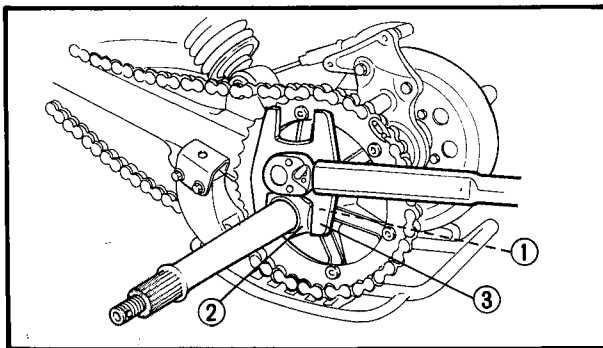
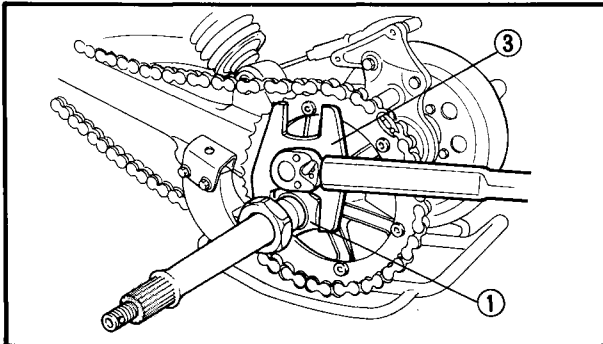
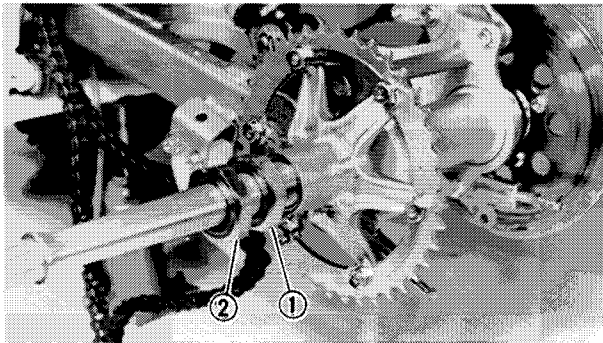

11. Tighten:

- Nut ① (Rear axle – Inner)
- Nut ② (Rear axle – Outer)

Rear axle nuts tightening steps:

NOTE:

Before tightening the nuts, apply the LOCTITE® to the thread portion of the rear axle.

- Tighten the nut (Inner) ① with the Nut Wrench ③ to specification while holding the rear axle.



Nut Wrench:
P/N. YM-37132
P/N. 90890-01419



Nut (Inner) – (First Tightening):
55 Nm (5.5 m·kg, 40 ft·lb)

- Hold the nut (Inner) ① and tighten the nut (Outer) ② with the Nut Wrench ③ to specification.



Nut (Outer):
190 Nm (19.0 m·kg, 140 ft·lb)

- Hold the nut (Outer) ② and tighten back the nut (Inner) ① with the Nut Wrench to specification.



Ring Nut (Inner) – (Final Tightening):
240 Nm (24.0 m·kg, 170 ft·lb)

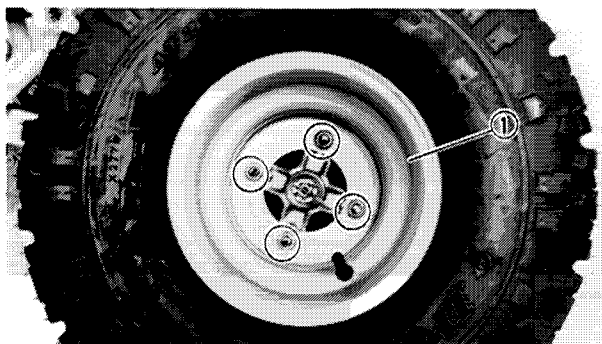

12. Install:

- Rear wheels ①
- Nuts (Rear wheel) – (Temporary tighten)

13. Remove the stand and set the machine on the ground securely.

14. Tighten:

- Nuts (Rear wheel)



Nut (Rear Wheel):
45 Nm (4.5 m·kg, 33 ft·lb)

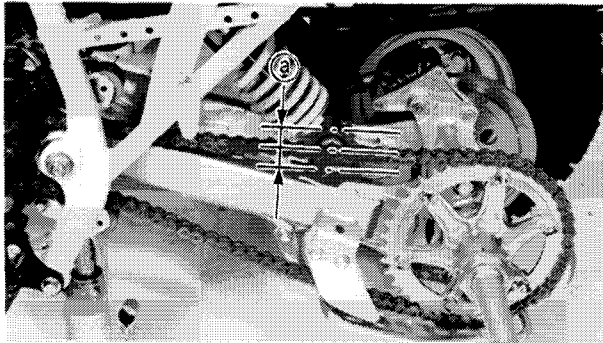

15. Release the parking brake.

16. Adjust:

- Drive chain slack @

Refer to the "DRIVE CHAIN SLACK ADJUSTMENT" section in the CHAPTER 3.



Drive Chain Slack:

30 ~ 40 mm (1.18 ~ 1.57 in)

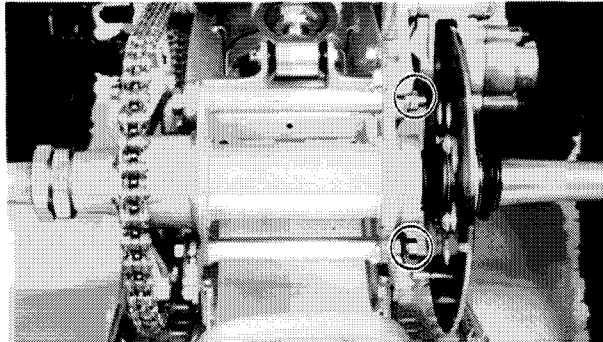

17. Tighten:

- Nut (Rear axle hub – Upper)
- Nut (Rear axle hub – Lower)



Nut (Rear Axle Hub – Upper and Lower):

50 Nm (5.0 m·kg, 36 ft·lb)



REAR BRAKE

- ① Brake caliper assembly
- ② Cover
- ③ Ratchet spring
- ④ Ratchet
- ⑤ Pin
- ⑥ Adjuster unit
- ⑦ Guide ring
- ⑧ Brake pad assembly
- ⑨ Brake caliper body
- ⑩ Grommet
- ⑪ Caliper body bracket
- ⑫ Wire clip
- ⑬ Brake disc hub cover
- ⑭ Brake disc hub
- ⑮ Brake disc
- ⑯ Dust cover

* SILICON GREASE
(In the brake pad repair kit.)

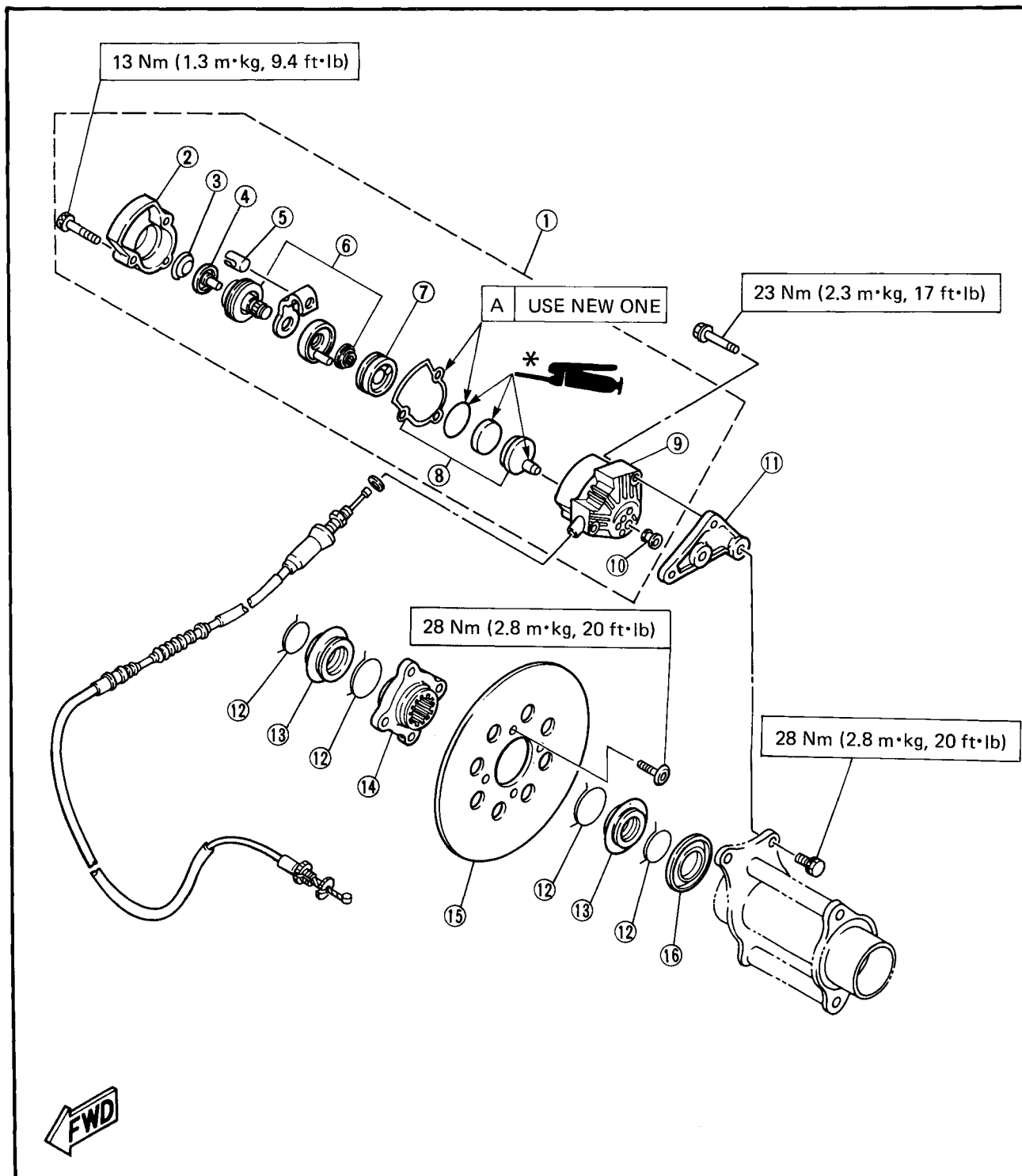

6

REMOVAL

CAUTION:

Disc brake components rarely require disassembly. DO NOT:

- Disassemble components unless absolutely necessary.
- Use solvents on internal brake component.

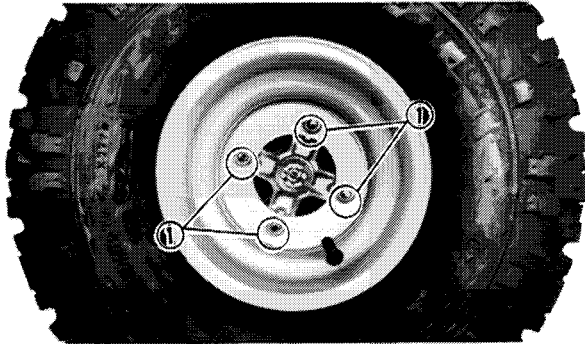

1. Place the machine on a level place.
2. Loosen:
 - Nuts ① (Rear wheel – Right)
3. Elevate the rear wheels by placing the suitable stand under the frame.

4. Remove:
 - Rear wheel (Right)
5. Apply the parking brake.

6

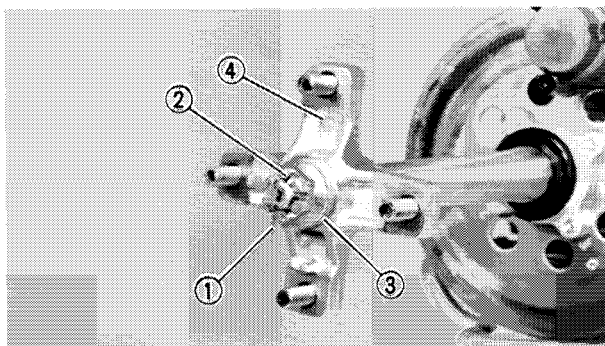

6. Remove:
 - Cotter pin ①
 - Nut ② (Wheel hub)
 - Plate washer ③
 - Wheel hub ④
7. Release the parking brake.

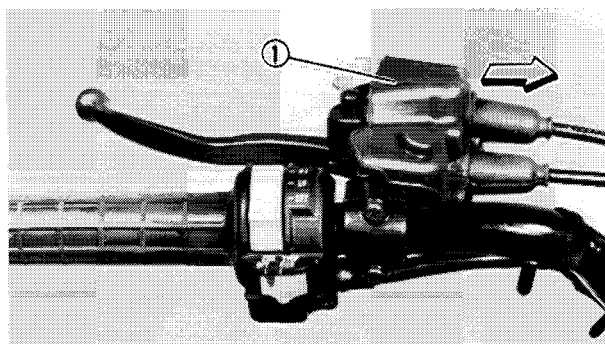

8. Pull back the cable adjuster cover ① from the clutch lever holder.

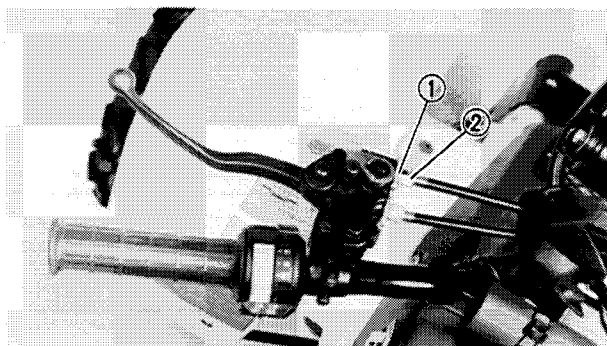

9. Loosen the locknut ① (Parking brake) and turn the adjuster ② clockwise to release the tension in the brake cable.

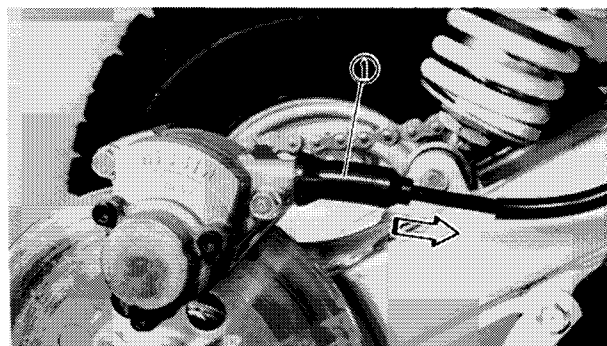

10. Pull back the cable adjuster cover ① from the rear brake caliper.

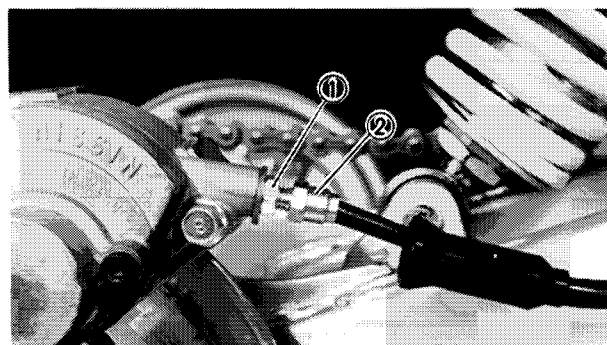

11. Loosen:
 • Locknut ①
 (until it stop)
 12. Turn the adjuster ② clockwise until it stop.

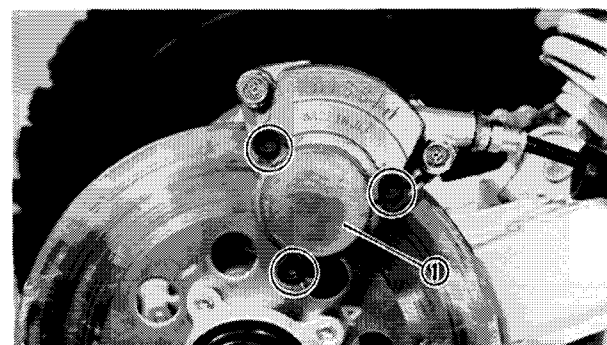

13. Remove:
 • Cover ① (Caliper)
 • Gasket

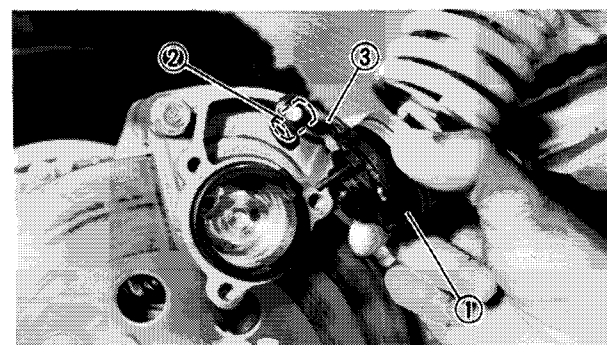

14. Take the adjuster unit ① out of the caliper body, and then detouch the pin ② from the adjuster arm ③.

6

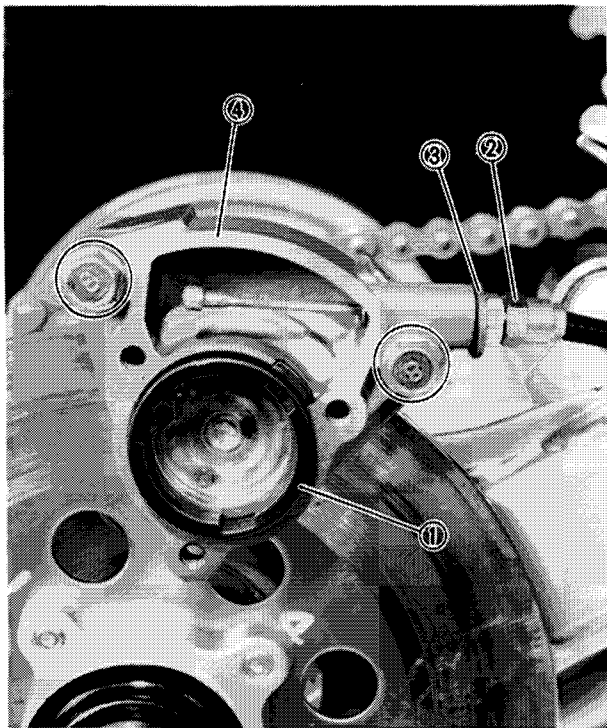

- 15. Remove:
 - Guide ring ①
- 16. Remove:
 - Brake cable adjuster ② (With brake cable)
 - Washer ③
- 17. Remove:
 - Caliper body ④

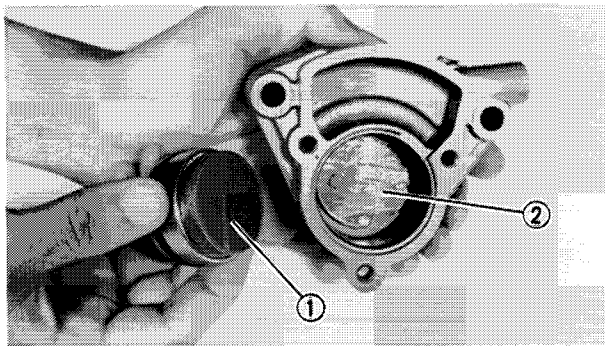

- 18. Remove:
 - Brake pad ① (Outer)
 - Brake pad ② (Inner)

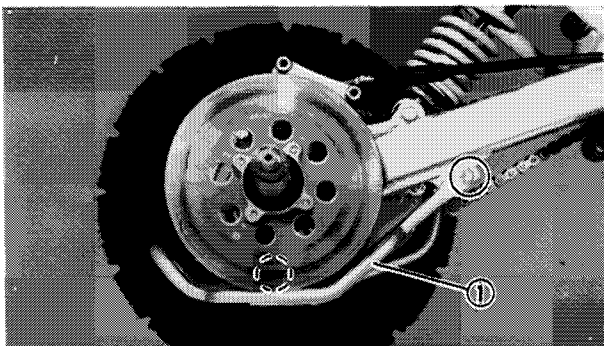

- 19. Remove:
 - Under guard ①

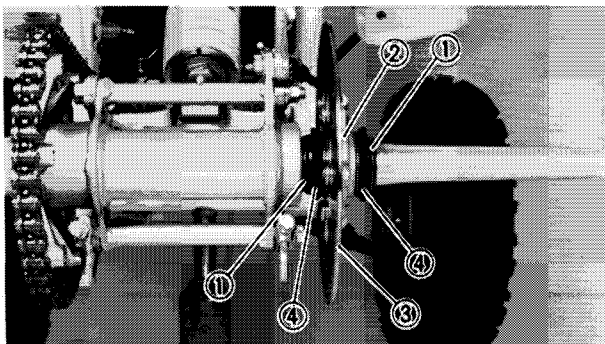

- 20. Remove:
 - Wire clips ①
 - Brake disc hub ②
 - Brake disc ③

⚠ CAUTION:

Remove the wire clip with a strict attention paid not to damage the brake disc hub cover ④.

6

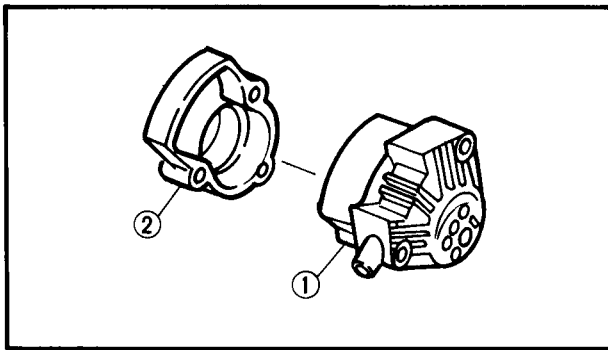

INSPECTION

1. Inspect:

- Caliper body ①
 - Cover ② (Caliper)
- Cracks/Damage → Replace.

2. Inspect:

- Adjuster unit
- Damage → Replace.

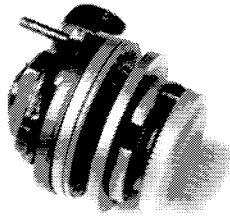

3. Inspect:

- Cam (Ratchet ①)
- Cracks/Wear/Damage → Replace.

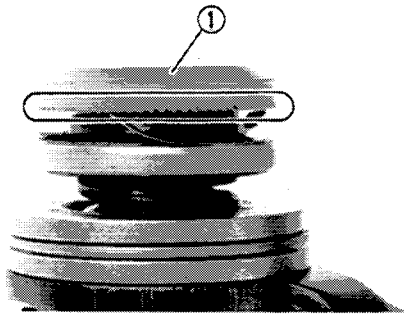

4. Inspect:

- Ratchet spring ①
- Wear/Damage → Replace.

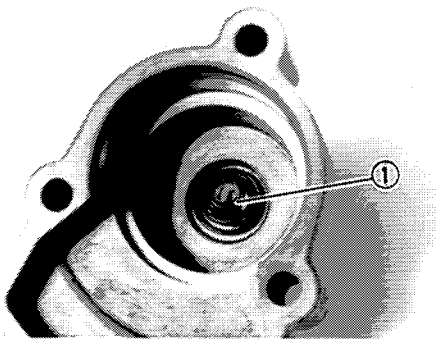

5. Inspect:

- Brake pad
- Over wear limit (a) → Replace as a set.

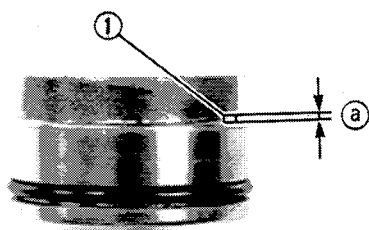

	<p>Wear Limit: 1.0 mm (0.0394 in)</p>
--	--

① Wear indicator

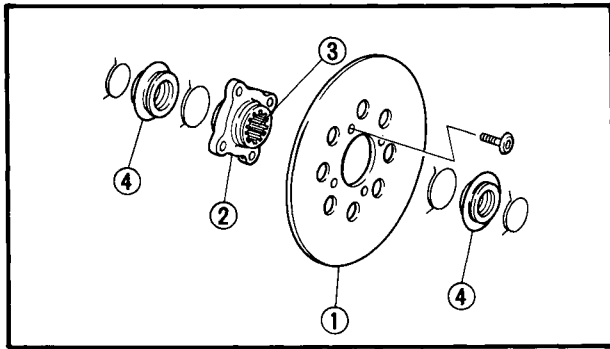

6. Inspect:

- Brake disc ①
Bend/Cracks/Damage → Replace.
- Brake disc hub ②
Cracks/Damage → Replace.
- Splines ③ (Brake disc hub)
Wear/Damage → Replace.
- Covers ④ (Disc hub)
Wear/Damage → Replace.

ASSEMBLY AND INSTALLATION

Reverse the "REMOVAL" procedures.
Note the following points.

NOTE:

In brake caliper reassembly, be sure to use following new parts.

- O-ring
- Gasket

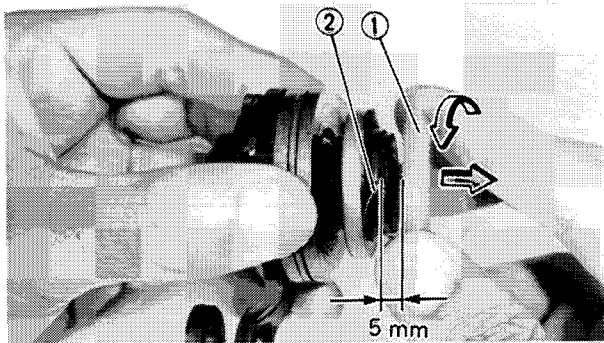

1. Adjust:

- Adjuster unit

Adjustment steps:

- Pull the ratchet ① toward yourself about 5 mm, making sure that the ratchet is not in contact with the stopper spring ② .
- Tighten the adjust bolt ③ by turning the ratchet ① counterclockwise until it stops.
- Push the ratchet back in place and make sure that it is in contact with the stopper spring.

6

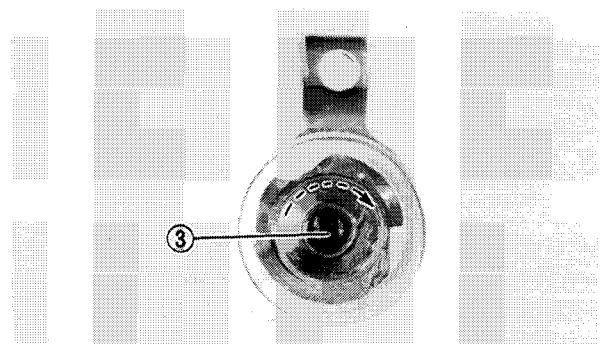

2. Install:

- Brake pads

Installation steps:

- Apply supplied (In the brake pad repair kit) silicon grease to the shaded section ① and the O-ring ② of the brake pads.

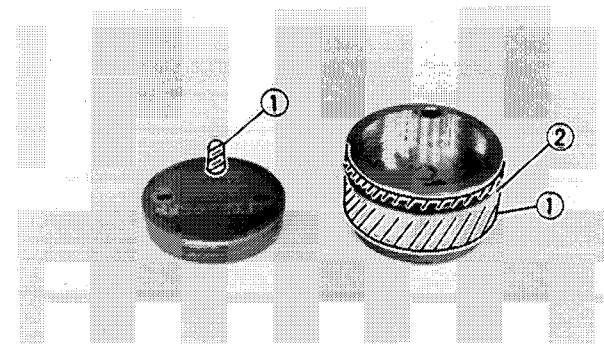

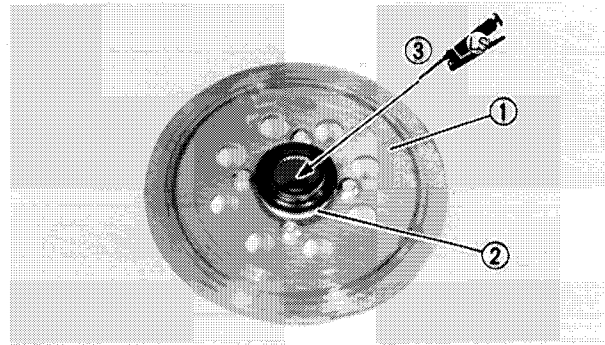
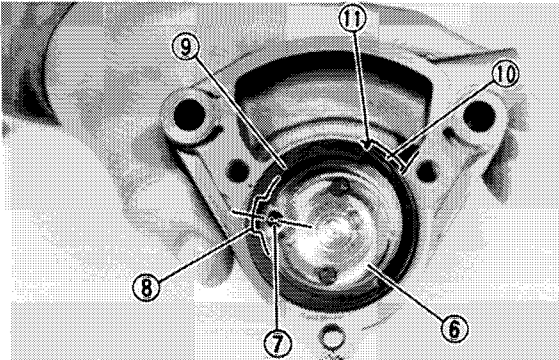
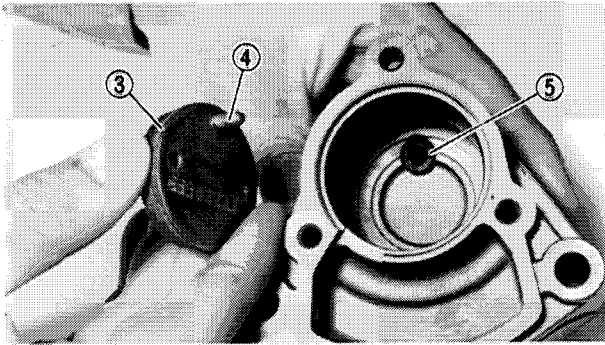

- Install the pad (Inner) ③ while making sure that the guide pin ④ is inserted in the grommet ⑤ on the caliper body.
- Install the pad (Outer) ⑥ in the caliper body in such a way that the guide hole ⑦ of the pad (Outer) aligns (In center) with the slot ⑧ of the guide ring ⑨ .
For proper seating of the guide ring ⑨ be sure that the guide projection ⑩ is seated in the cut-out ⑪ of the caliper body.
- Remove the guide ring ⑨ .

3. Install:

- Brake disc ①
(to brake disc hub ②)

	Bolt (Brake Disc): 28 Nm (2.8 m·kg, 20 ft·lb)
--	---

4. Lubricate:

- Splines ③ (Brake disk hub)

	Lightweight Lithium-soap Base Grease
--	---

6

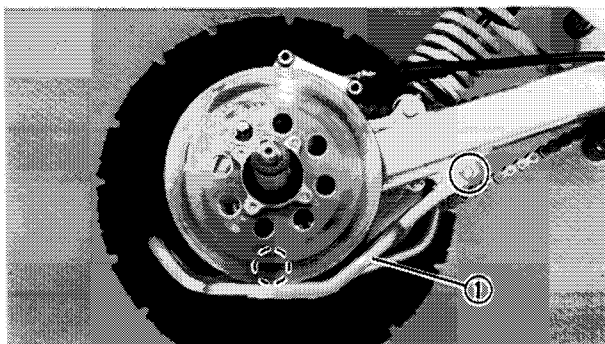

5. Install:

- Under guard ①

	Bolt (Under Guard): 23 Nm (2.3 m·kg, 17 ft·lb)
--	--

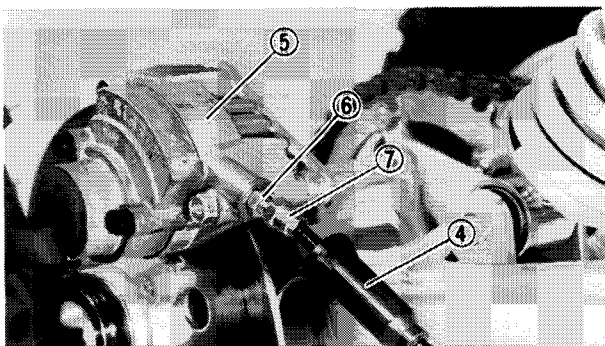
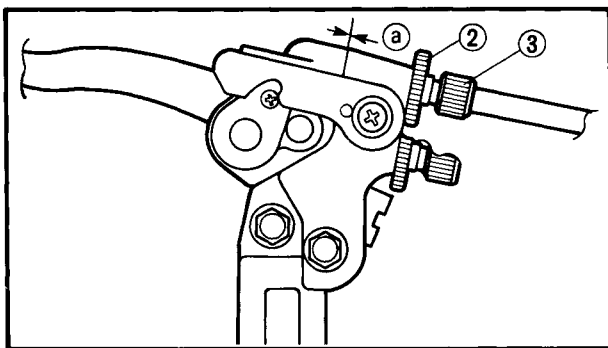
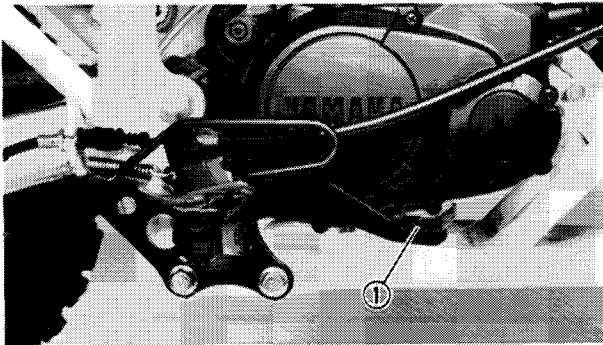
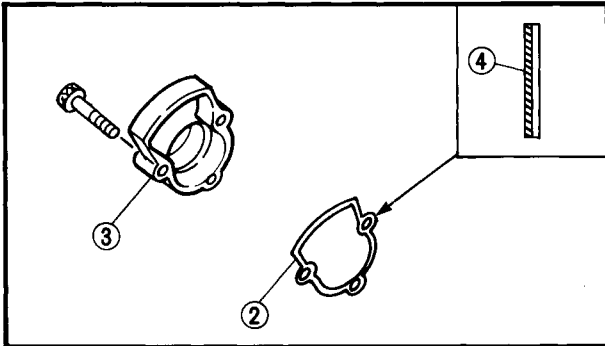
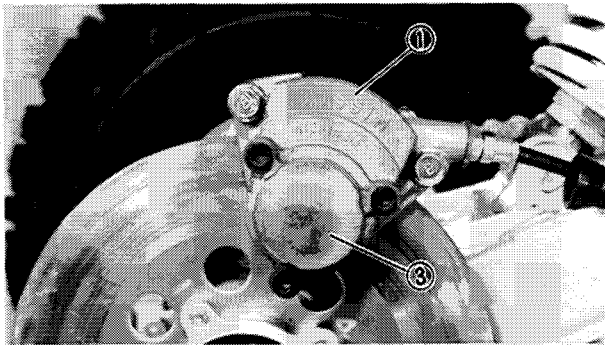

6. Install:

- Caliper body ①
- Gasket ② (Caliper cover)
- Caliper cover ③

	Bolt (Caliper Body): 23 Nm (2.3 m·kg, 17 ft·lb)
	Bolt (Caliper Cover): 13 Nm (1.3 m·kg, 9.4 ft·lb)

NOTE:

Install the gasket with its adhesive side ④ facing the caliper cover.

⚠ WARNING:

Always use a new gasket.

7. Install:

- Wheel hub (Rear wheel – Right)
 - Rear wheel (Right)
- Refer to the "REAR WHEEL AND REAR AXLE – INSTALLATION" section.

8. Adjust:

- Parking brake

Adjustment steps:

- Apply the rear brake repeatedly by pressing on the rear brake pedal ① until the pedal strokes become constant. (The adjust bolt of the adjuster unit is in contact with the pad).
- Pull back the adjuster cover from the left lever holder.
- Loosen the locknut ② and turn in the parking brake cable adjuster ③ on the left lever holder.
- Pull back the adjuster cover ④ on the rear brake caliper body ⑤.
- Loosen the locknut ⑥ and turn in the cable adjuster ⑦.
- Turn the adjuster ⑦ counterclockwise until the parking cable free play ⑧ becomes 0, or as close to 0 as possible.
- Turn the adjuster ⑥ counterclockwise once, and tighten the locknut ⑦.

	Locknut: 13 Nm (1.3 m·kg, 9.4 ft·lb)
---	--

6

**⚠ CAUTION:**

When tightening the locknut, hold the adjuster with a spanner so that the adjuster is not turned together with the locknut.

- Set the adjuster cover ④ onto the rear brake caliper body ⑤.
- Tighten the locknut ② on the left lever holder.
- Set the adjuster cover to the left lever holder.

⚠ WARNING:

After this adjustment is performed, block the rear of the machine off the ground, and spin the rear wheels to ensure there is no brake drag. If any brake drag is noticed, perform the above steps again.

STEERING SYSTEM

- ① Handlebar cover stay
- ② Handlebar holder (Upper)
- ③ Handlebar holder (Lower)
- ④ Headlight stay
- ⑤ Bearing (Lower)
- ⑥ Oil seal
- ⑦ Bearing (Upper)
- ⑧ Collar
- ⑨ Cable holder
- ⑩ Lock washer
- ⑪ Steering column
- ⑫ Cotter pin
- ⑬ Rod-end
- ⑭ Locknut
- ⑮ Tie-rod
- ⑯ Steering knuckle
- ⑰ Knuckle arm
- ⑱ Washer
- ⑲ Bushing
- ⑳ O-ring

6

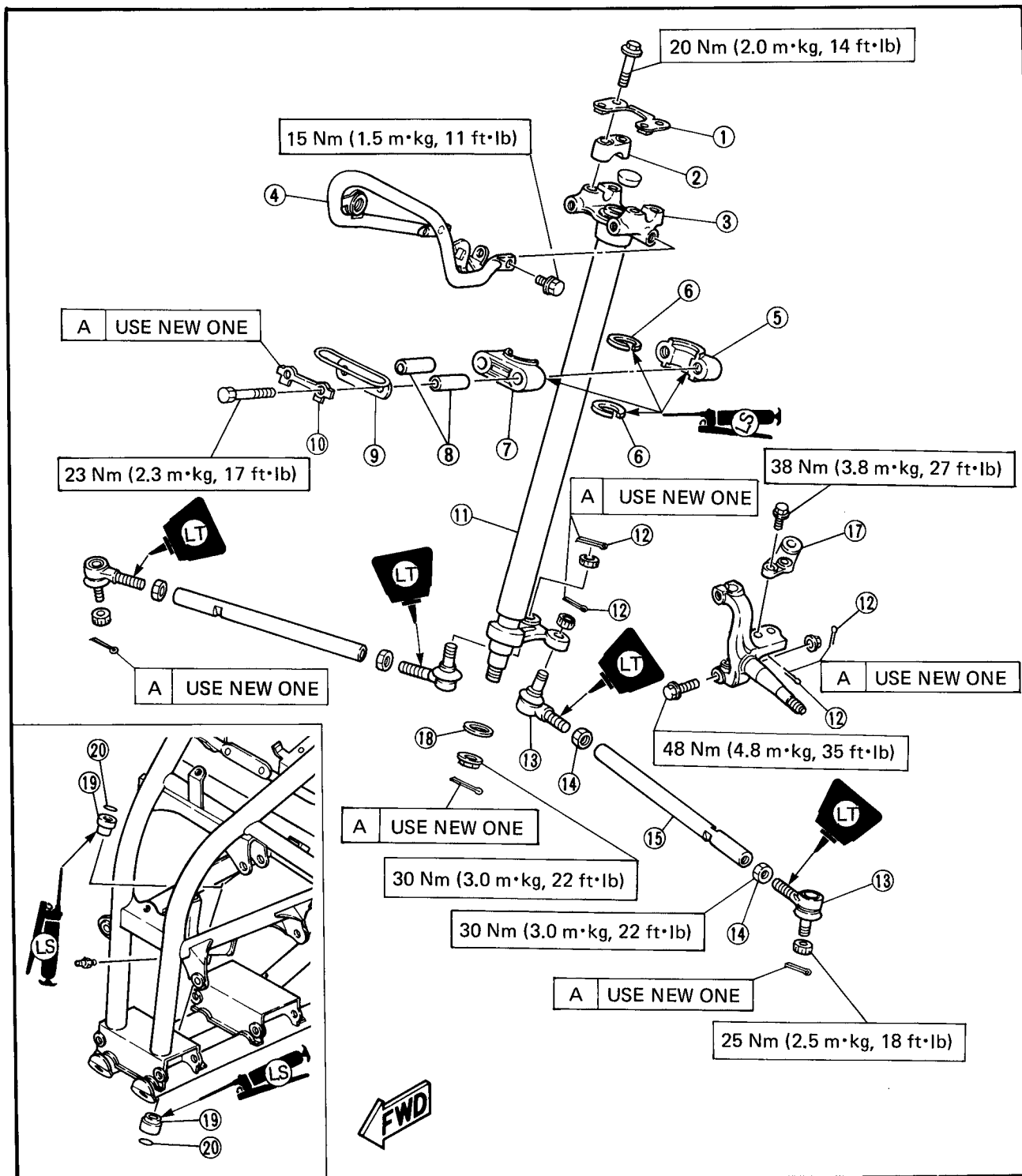

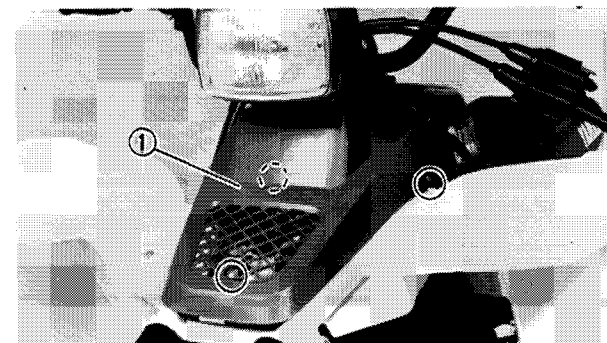
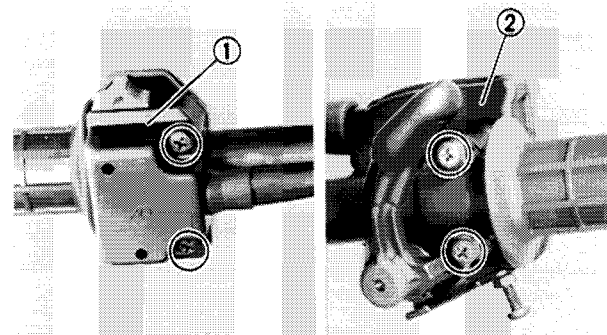
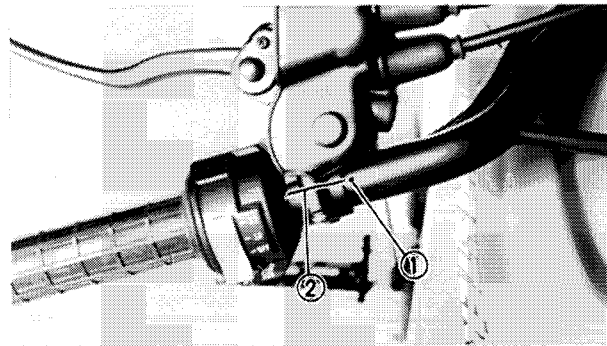
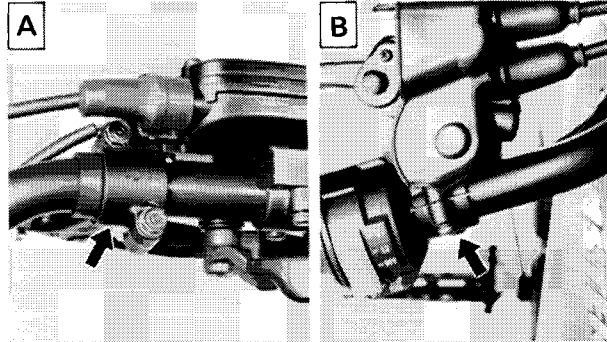
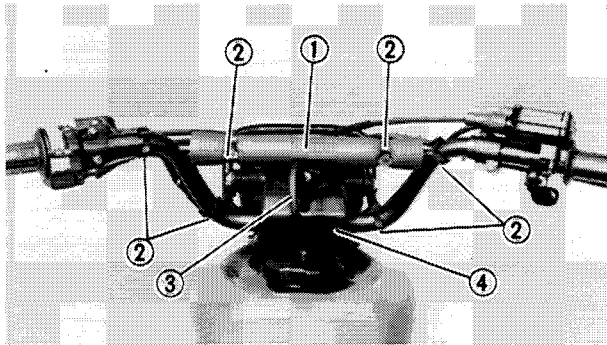

REMOVAL

1. Remove:
 - Protector ① (Handlebar)
 - Bands ②
2. Disconnect:
 - Fuel breather hose ③ (from handlebar cover ④)
3. Remove:
 - Lever holder
 - Lever holder

- A Right
- B Left

NOTE:

Place an aligning mark ① next to the separating line ② of the lever holder before removal so that it can be reinstalled in the original position.

4. Remove:
 - Handlebar switch ①
 - Throttle housing ②

5. Remove:
 - Cover ① (Front)

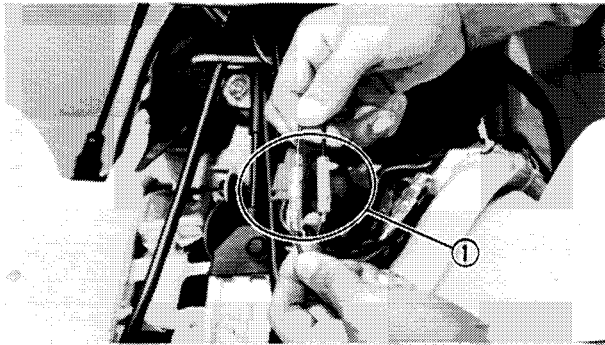

6. Disconnect:
- Main switch leads ①

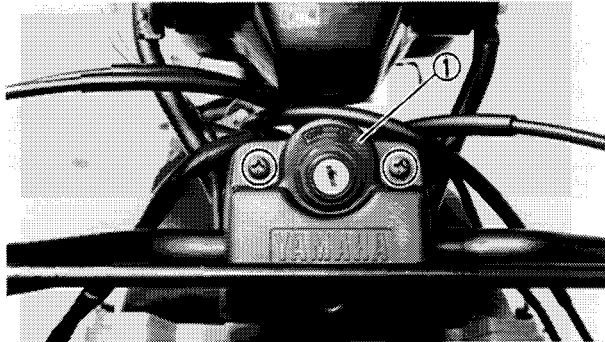

7. Remove:
- Cover ① (Handlebar)

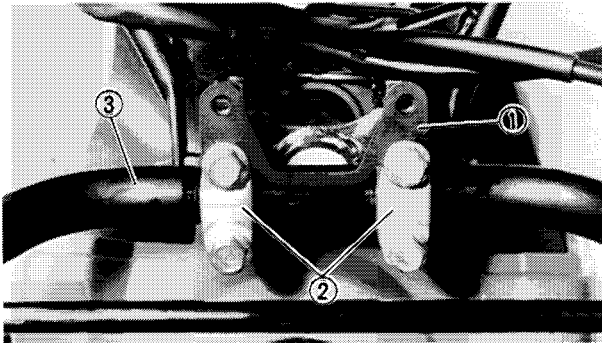

8. Remove:
- Stay ① (Handlebar cover)
 - Handlebar holders ②
 - Handlebar ③

6

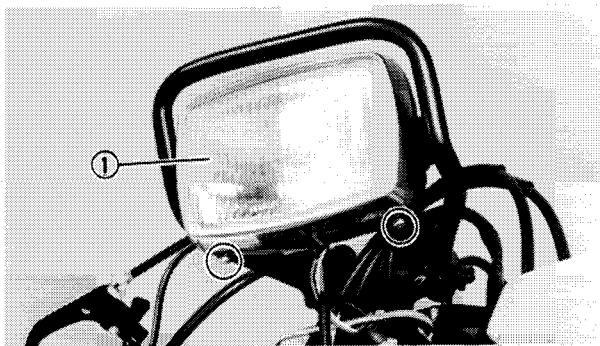

9. Remove:
- Headlight lens unit ①

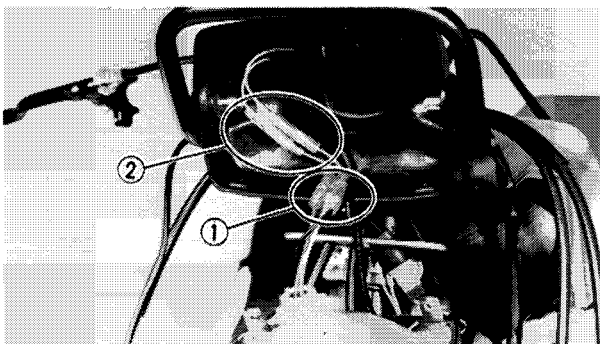

10. Disconnect:
- Headlight leads ①
 - Oil level indicator light leads ②

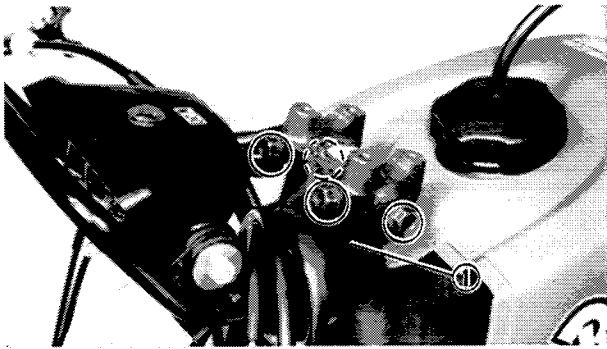

11. Remove:
- Headlight stay ①

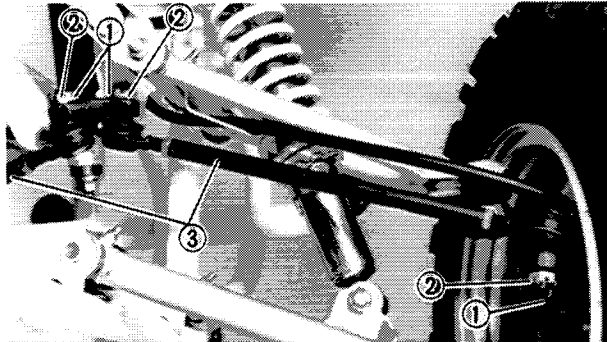

12. Remove:
- Cotter pins ①
 - Nuts ②
 - Tie-rods ③

NOTE: _____
 Remove the rod-end of the tie-rod from the steering column and knuckle arm, using the General Bearing Puller.

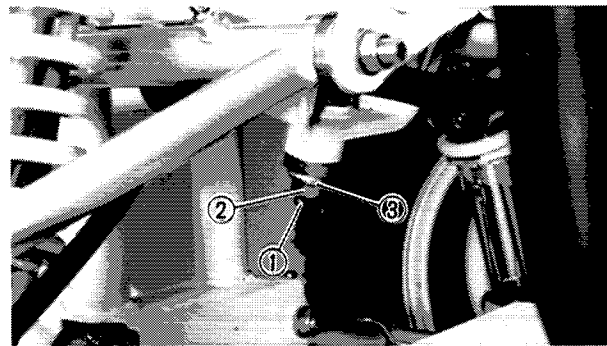

13. Remove:
- Cotter pin ①
 - Nut ② (Steering column)
 - Washer ③

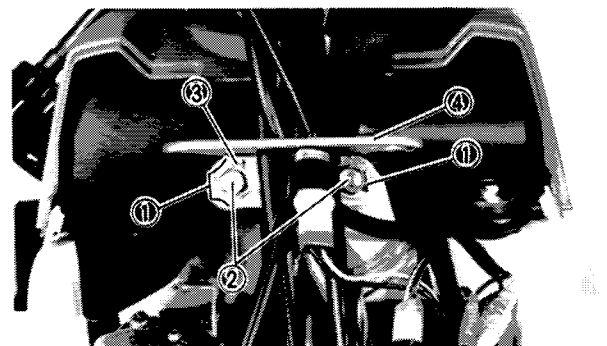

14. Straighten:
- Lock washer tabs ①
15. Remove:
- Bolts ② (Steering column holder)
 - Lock washer ③
 - Cable holder ④

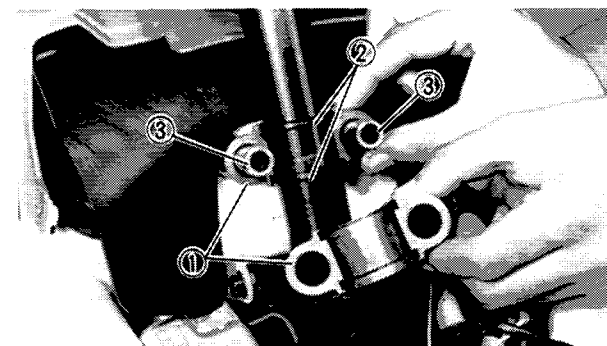

16. Remove:
- Bearings ① (Steering column)
 - Oil seals ②
 - Collars ③

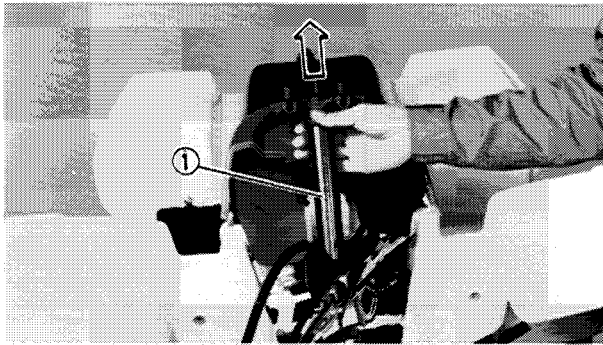

17. Remove:
- Steering column ①
(from upside)

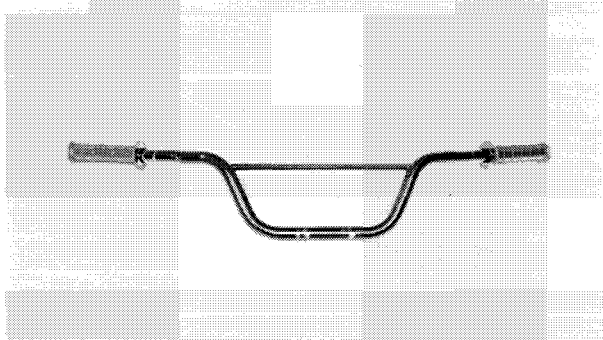

INSPECTION

1. Inspect:
- Handlebar
Cracks/Bends/Damage → Replace.

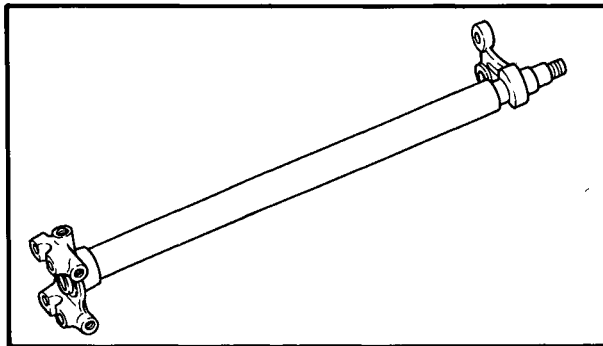

2. Inspect:
- Steering column
Bends/Damage → Replace.

⚠ WARNING:

Do not attempt to straighten a bent shaft; this may dangerously weaken the shaft.

6

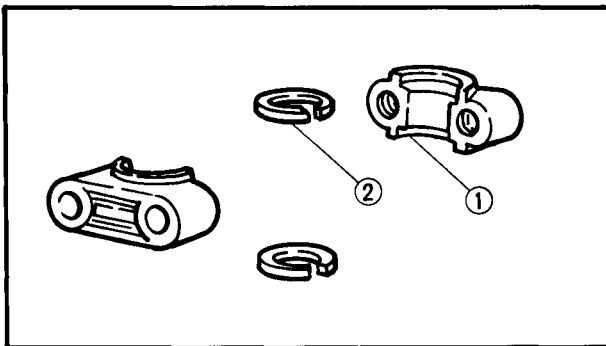

3. Inspect:
- Bearing ① (Steering column)
 - Oil seal ②
Wear/Damage → Replace.

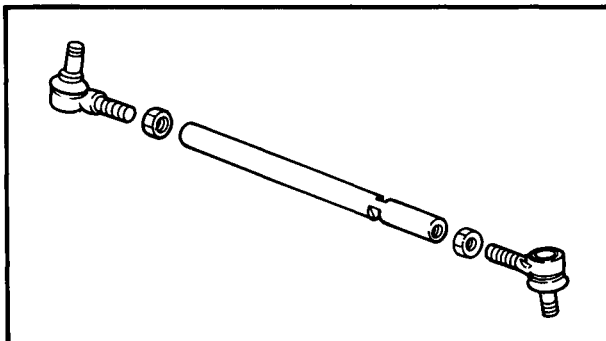

4. Inspect:
- Tie-rod
Bend/Damage → Replace.

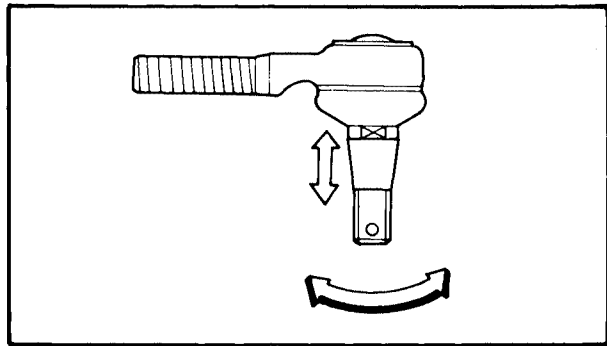

5. Check:
- Tie-rod end movement
Tie-rod end exists free play → Replace.
Tie-rod end turns roughly → Replace.
 - Tapered surface (Tie-rod end)
Pitting/Wear/Damage → Replace.

6. Adjust:
- Tie-rod length and rod-end angle

Adjustment steps:

(The following procedures are done on both tie-rods, right and left:)

- Loosen the locknuts ①.
- Adjust the tie-rod length ② by turning both tie-rod ends.

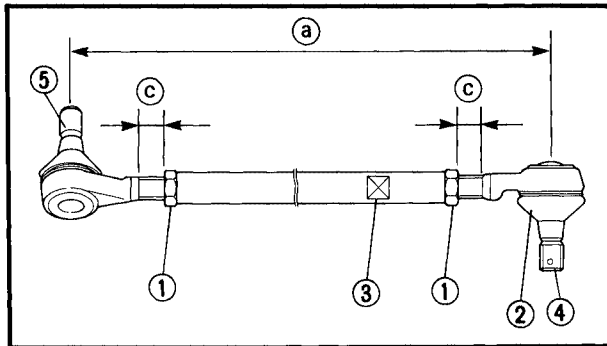

Tie Rod Length:
321 mm (12.6 in)

- Set the rod-end ② (Knuckle arm side) in an angle where the indentation surface ③ of the tie-rod is parallel to the rod-end shaft ④, and then tighten the locknut.



Locknut (Rod-End):
30 Nm (3.0 m · kg, 22 ft · lb)

- Set the other rod-end ⑤ (Steering column side) in an angle as shown in figures A and B, and then tighten the locknut.

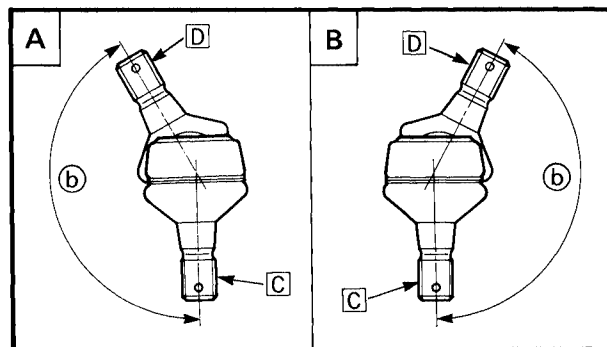

Rod-End (Tie Rod) Angle (b) :
164° ~ 166°



Locknut (Rod-End):
30 Nm (3,0 m · kg, 22 ft · lb)

NOTE:
The threads ③ on both rod-ends must be of the same length.

- After making adjustment on both tie rods, be sure to mark them R and L for identification.

- A Right-hand tie-rod
- B Left-hand tie-rod
- C To knuckle arm
- D To steering column

6

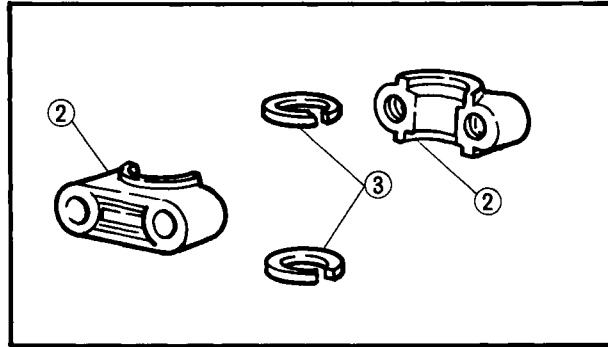
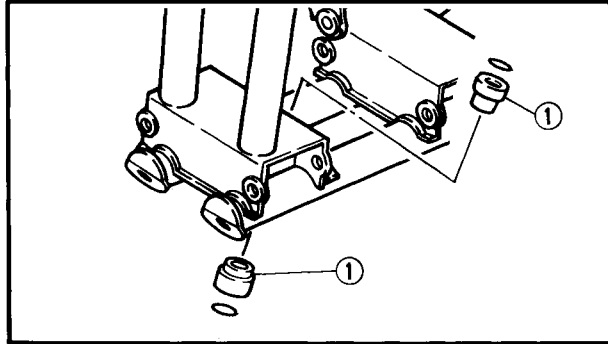
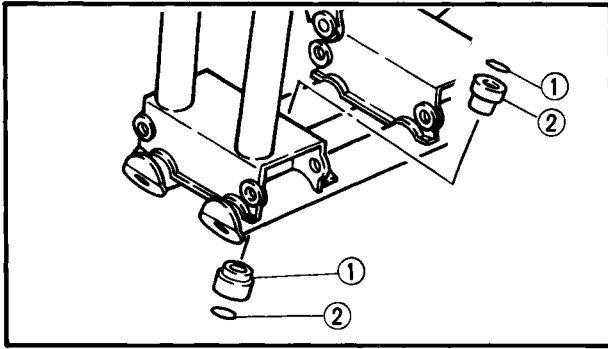

7. Inspect:

- Bushing ①
- O-ring ②
- Wear/Damage → Replace.

INSTALLATION

Reverse the "REMOVAL" procedures. Note the following points.

1. Lubricate:

- Bushings ① (Steering column)
- Bearings ② (Steering column)
- Oil seal ③ (Lip)

	Lightweight Lithium-Soap: Base Grease
---	--

6

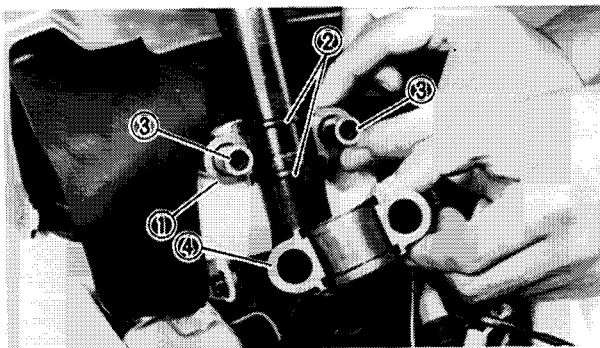

2. Install:

- Bearing ① (Lower)
- Oil seals ②
- Collars ③
- Bearing ④ (Upper)

NOTE: _____
Be careful not to damage the oil seals during installation.

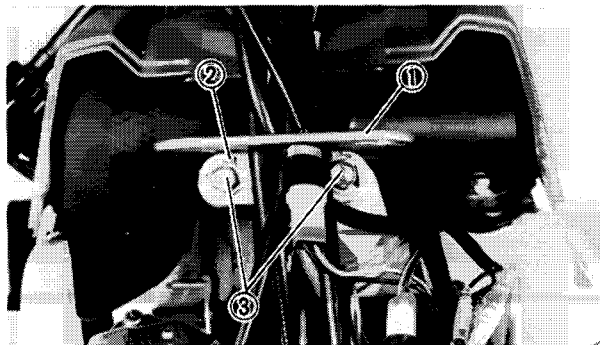

3. Install:

- Cable holder ①
- Lock washer ② (New)
- Bolts ③ (Steering Column Holder)

	Bolt (Steering Column Holder): 23 Nm (2.3 m · kg, 17 ft · lb)
---	--

⚠ WARNING:

Always use a new lock washer.

4. Bend the lock washer tab along the bolt flats.

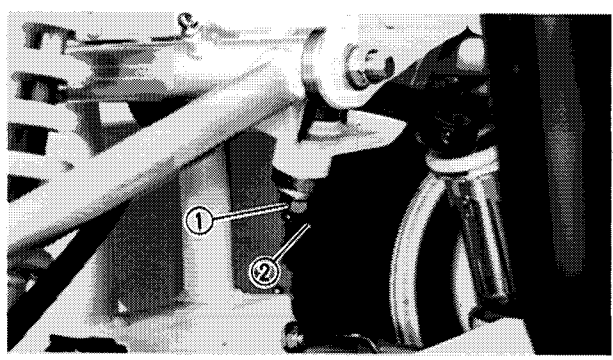

5. Tighten:
 • Nut ① (Steering column)

	Nut (Steering Column): 30 Nm (3.0 m·kg, 22 ft·lb)
---	---

6. Install:
 • Cotter pin ② (New)

⚠ WARNING:

Always use a new cotter pin.

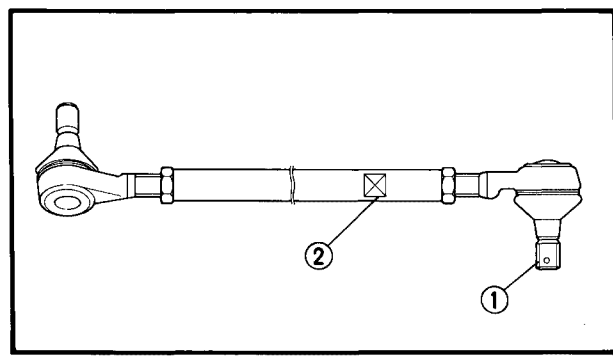

7. Install:
 • Tie-rods (Left and right)

NOTE:
 Be sure that the rod-end ① on the identification ② side is connected to the knuckle arm.

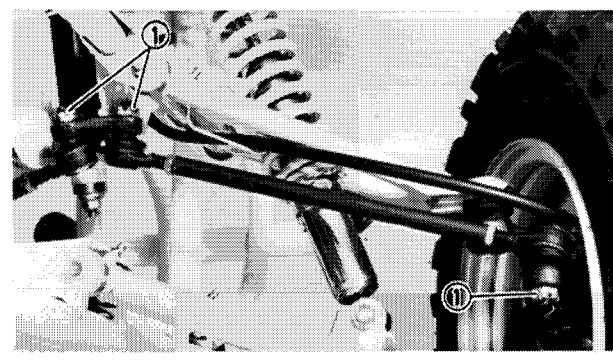

8. Tighten:
 • Nuts ① (Tie-rod)

	Nut (Tie-Rod): 25 Nm (2.5 m·kg, 18 ft·lb)
---	---

9. Install:
 • Cotter pin (New)

⚠ WARNING:

Always use a new cotter pin.

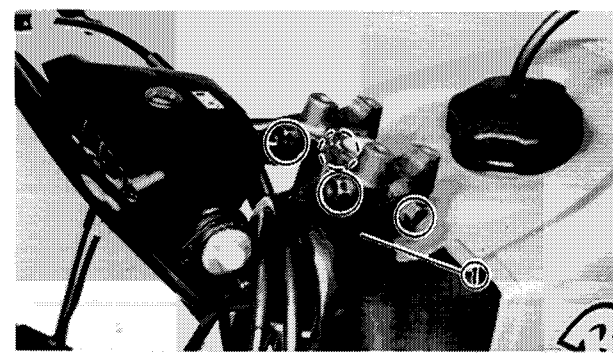

10. Tighten:
 • Bolts (Headlight stay ①)

	Bolt (Headlight Stay): 15 Nm (1.5 m·kg, 11 ft·lb)
---	---

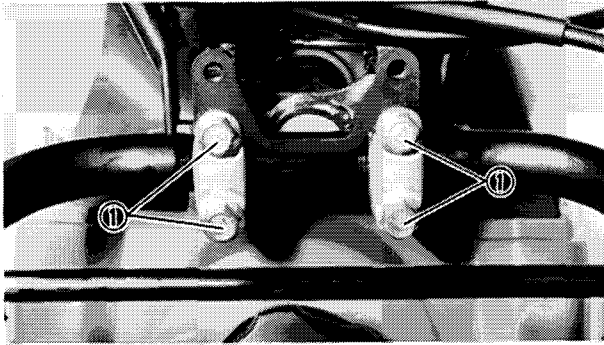

11. Tighten:
- Bolts ① (Handlebar holder)



Bolt (Handlebar Holder):
20 Nm (2.0 m·kg, 14 ft·lb)

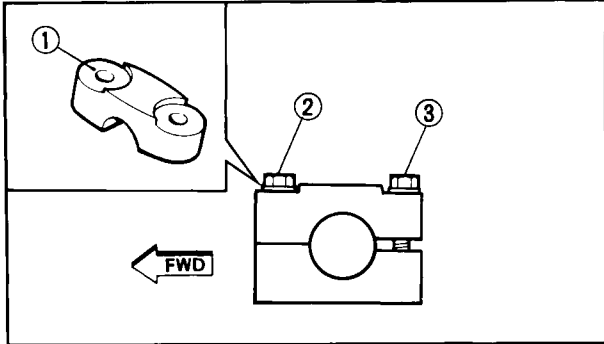

NOTE: _____
Be sure the upper handlebar holder mark ① face to front.

CAUTION: _____

First tighten the bolts ② on the front side of the handlebar holder, and then tighten the bolts ③ on the rear side.

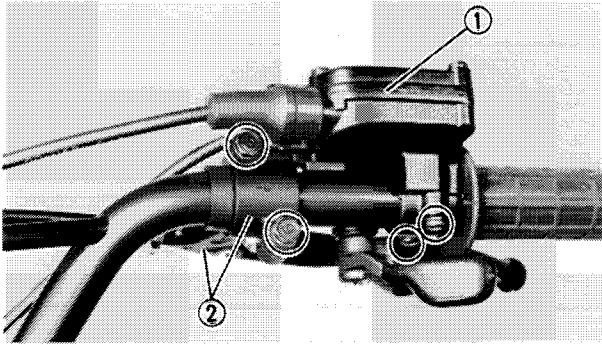

12. Install:
- Throttle housing ①
 - Front brake lever ②



Bolt (Front Brake Lever):
10 Nm (1.0 m·kg, 7.2 ft·lb)

6

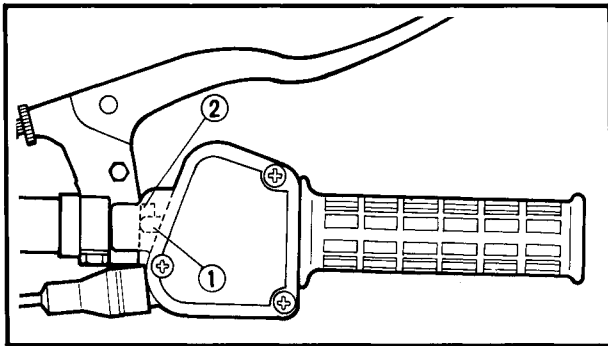

NOTE: _____
Fit the throttle housing projection ① onto the indent ② on the front brake lever.

WARNING: _____

Proper cable and lead routing is essential to assure safe machine operation. Refer to the "CABLE ROUTING" section in the CHAPTER 2.



13. Adjust:

- Toe-in

Refer to the "TOE-IN ADJUSTMENT"
section in the CHAPTER 3.

FRONT SHOCK ABSORBER AND FRONT ARMS

- ① Thrust cover
- ② Bushing
- ③ Front arm (Upper)
- ④ Inner collar
- ⑤ Knuckle arm
- ⑥ Steering knuckle
- ⑦ Shock absorber assembly
- ⑧ Front arm (Lower)

A	FRONT SHOCK ABSORBER
B	STANDARD POSITION: B
C	SOFTEST POSITION: A
D	STIFFEST POSITION: E

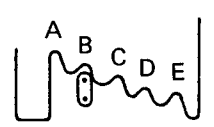
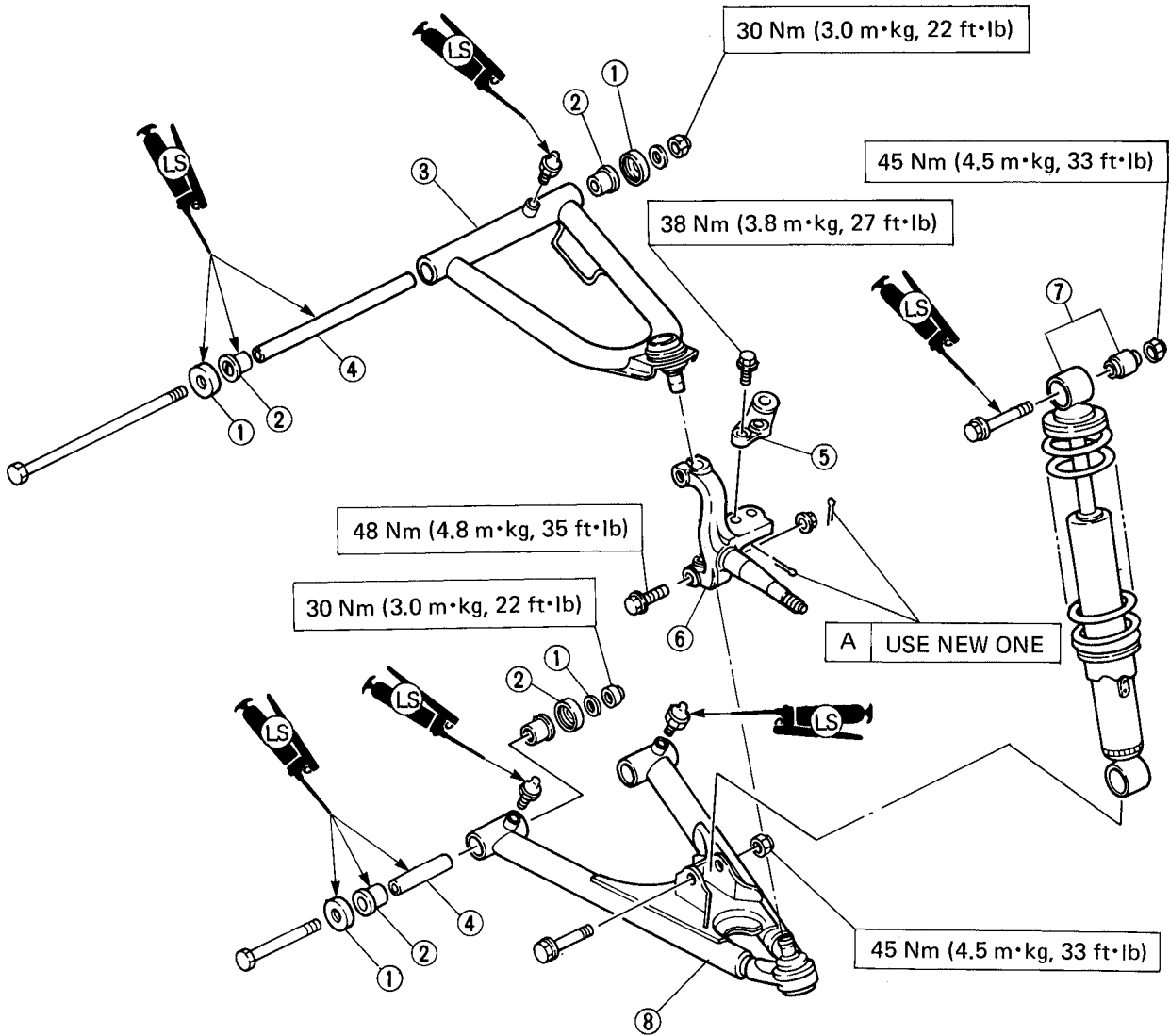
6



REMOVAL

1. Remove:

- Front wheel
- Wheel hub
- Brake shoe plate

Refer to the "FRONT WHEEL AND FRONT BRAKE" section.

2. Remove:

- Front bumper

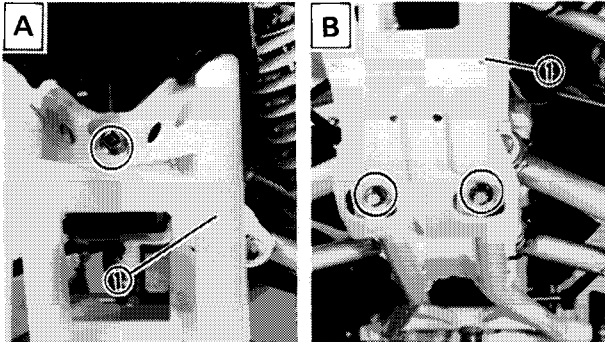

A Upper
B Lower

3. Remove:

- Shock absorber ① (Front)

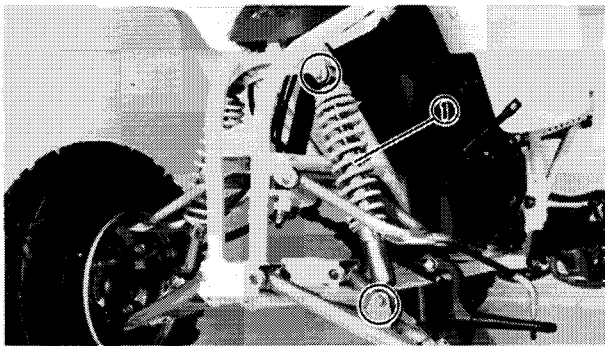

4. Remove:

- Cotter pin ①
- Nut ②
- Tie-rod ③
(from knuckle arm side)

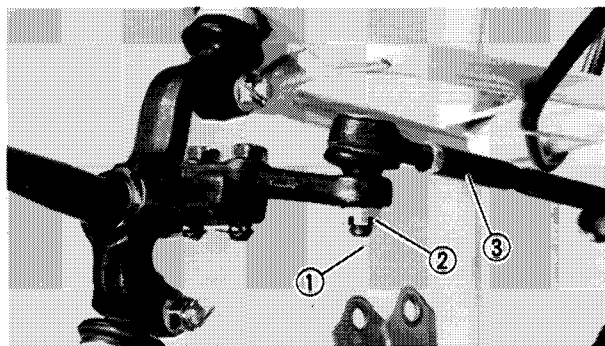

5. Remove:

- Cotter pins ①
- Bolts ②
- Knuckle arm ③

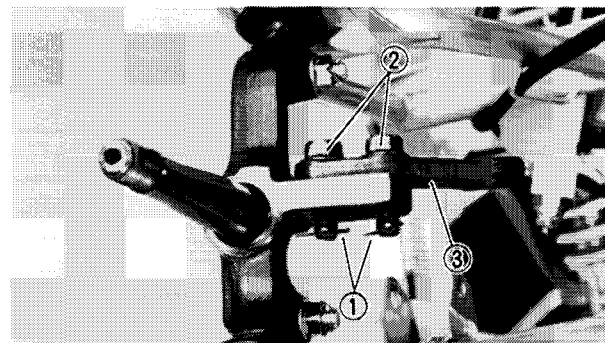

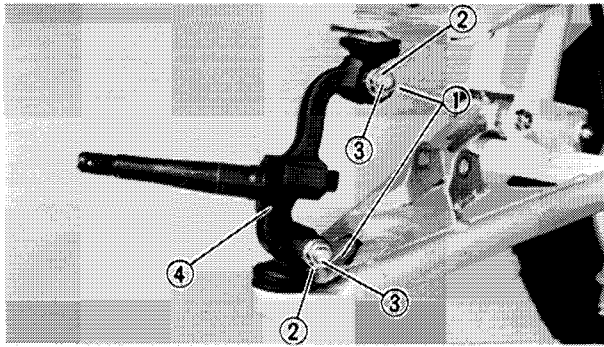

6. Remove:
- Cotter pins ①
 - Nuts ②
 - Bolts ③
 - Steering knuckle ④

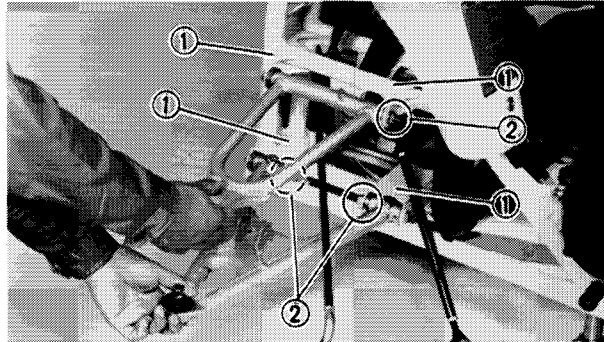

7. Check:
- Front arms free play

Front arms free play inspection steps:

- Check the front arm brackets ① of the frame. If bent, cracked or damaged, repair or replace the frame.
- Check the tightening torque of the front arms (Upper and Lower) securing nuts ②.

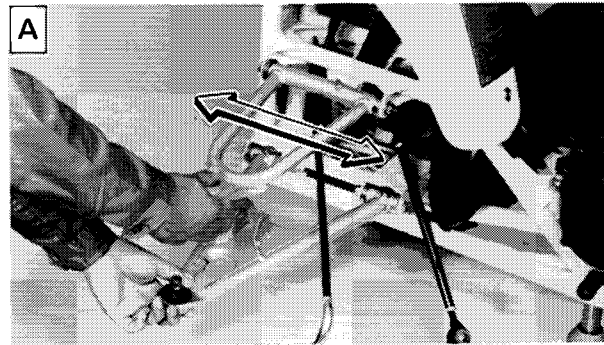

Nut (Front Arm – Upper and Lower):
30 Nm (3.0 m·kg, 22 ft·lb)

- Check the front arms (Upper and Lower) side play **A** by moving it from side to side. If side play noticeable, replace the inner collar, bushings and thrust covers as a set.
- Check the front arms (Upper and Lower) vertical movement **B** by moving it up and down.

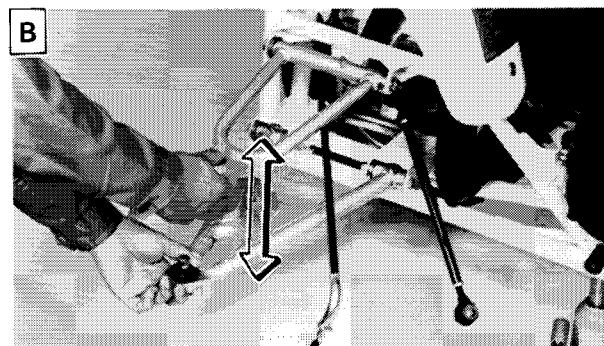

If vertical movement is tight, binding or rough, replace the inner collar, bushings and thrust covers as a set.

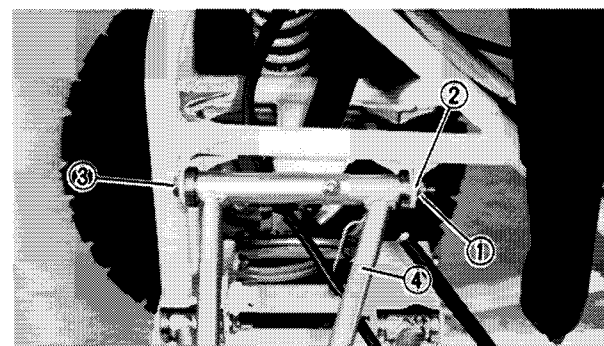

8. Remove:
- Nut ①
 - Washer ②
 - Bolt ③
 - Front arm ④ (Upper)

6

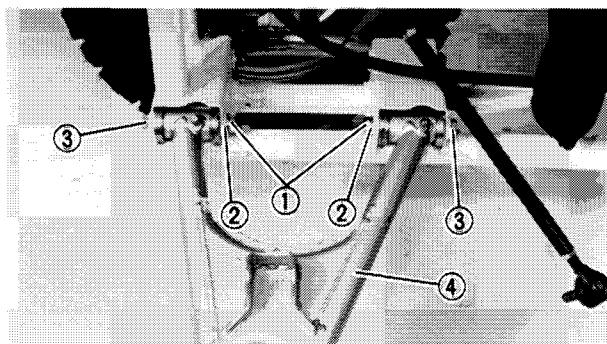

9. Remove:
- Nuts ①
 - Washers ②
 - Bolts ③
 - Front arm ④ (Lower)

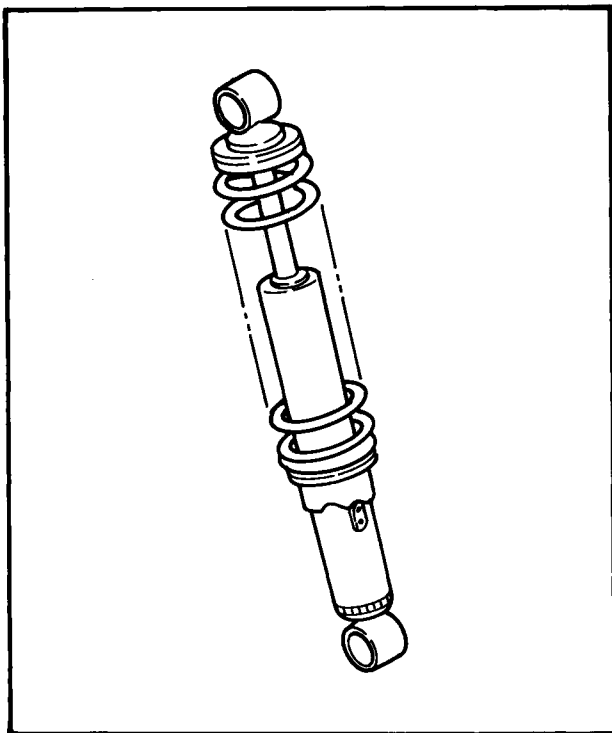

INSPECTION

1. Inspect:
- Shock absorber rod
Bends/Damage → Replace the shock absorber assembly.
 - Shock absorber
Oil leakes → Replace the shock absorber assembly.
 - Spring
Fatigue → Replace the shock absorber assembly.
Move the spring up and down.

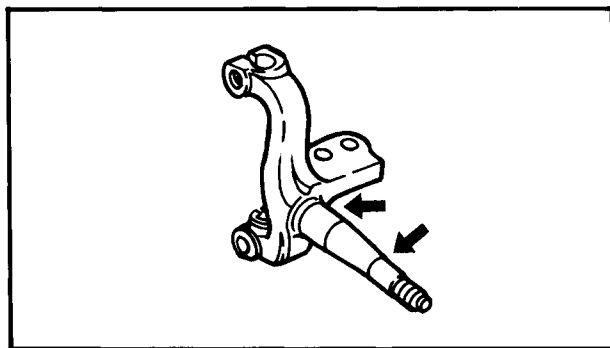

2. Inspect:
- Steering knuckle
Cracks/Pitting/Damage → Replace.

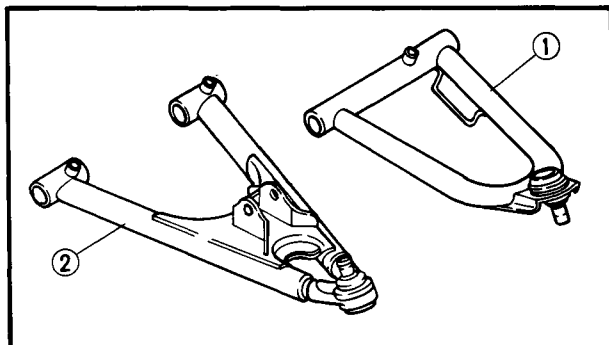

3. Inspect:
- Front arms (Upper ① and Lower ②)
Cracks/Bends/Damage → Replace.

⚠ WARNING:

Do not attempt to straighten a bent arm; this may dangerously weaken the arm.

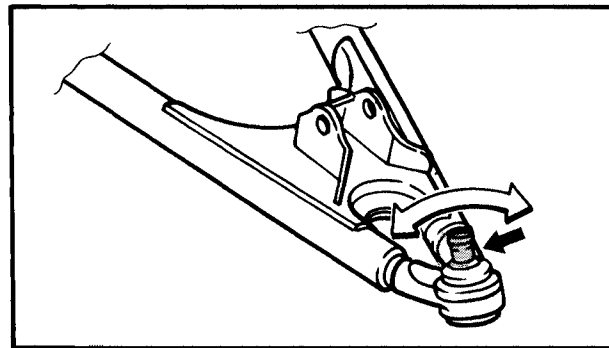
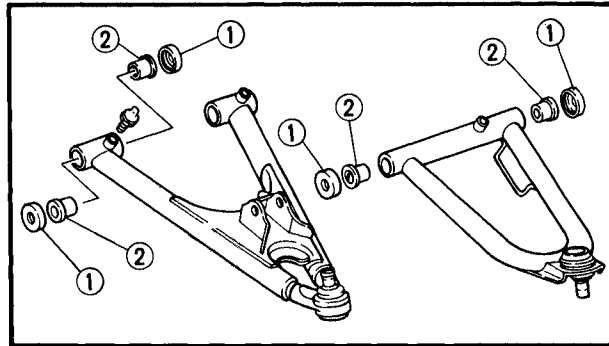
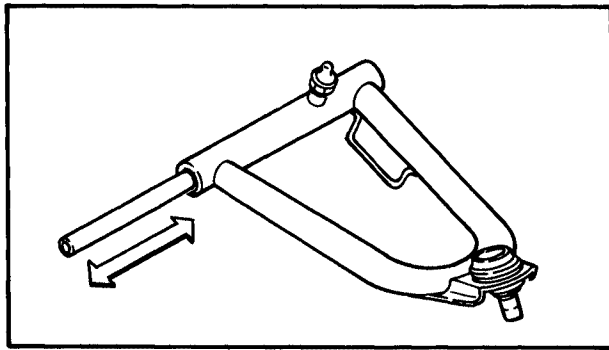

4. Check:
 Inner collar free play
 Inner collar is loose → Replace inner collar and bushings as a set.
 Insert the inner collar into the front arm, and check for free play.

5. Inspect:
 • Thrust covers ①
 • Bushings ②
 Wear/Damage → Replace as a set.

6. Check:
 • Ball joint movement
 Exists free play → Replace the front arm assembly.
 Turns roughly → Replace the front arm assembly.
 • Ball joint shaft surface
 Pitting/Wear/Damage → Replace the front arm assembly.

6

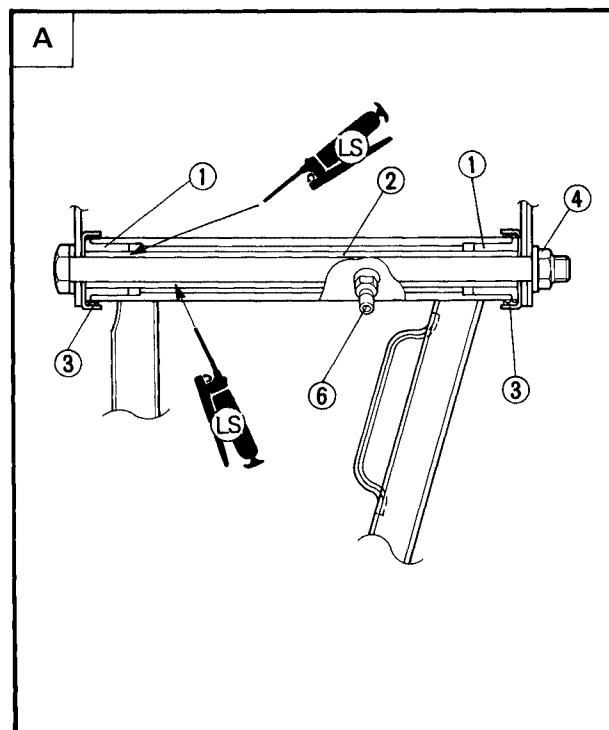

INSTALLATION

Reverse the "REMOVAL" procedures.
 Note the following points.

1. Lubricate:
- Bushings ① (Inner surface)
 - Inner collars ② (Inner surface)
 - Thrust covers ③ (Inner surface and lips)

	Lightweight Lithium-soap Base Grease
---	---

2. Tighten:
- Nut ④ (Front arm – Upper)
 - Nut ⑤ (Front arm – Lower)

	Nut (Front Arm – Upper and Lower): 30 Nm (3.0 m·kg, 22 ft·lb)
---	--

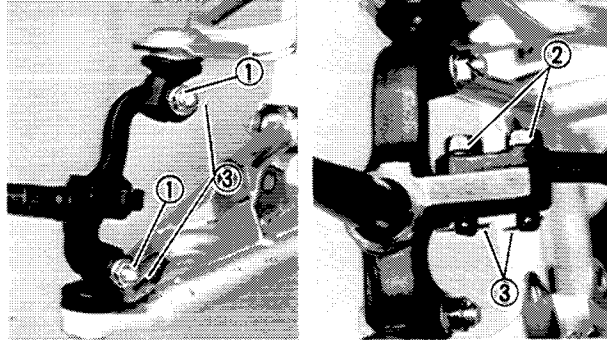
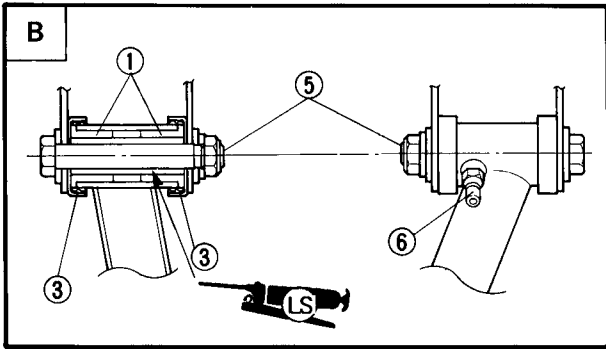

3. Inject grease from the nipples ⑥ using a grease gun until slight overflow is observed from the thrust covers.

 **Lightweight Lithium-Soap Base Grease**

- A Front arm – upper section
- B Front arm – lower section

4. Tighten:

- Nuts ① (Steering knuckle)
- Bolts ② (Knuckle arm)

 **Nut (Steering Knuckle):**
48 Nm (4.8 m · kg, 35 ft · lb)
Bolt (Knuckle Arm):
38 Nm (3.8 m · kg, 27 ft · lb)

⚠ WARNING:

Always use a new cotter pin ③ .

5. Connect:

- Tie-rod (to knuckle arm)

Refer to the "STEERING SYSTEM – INSTALLATION" section.

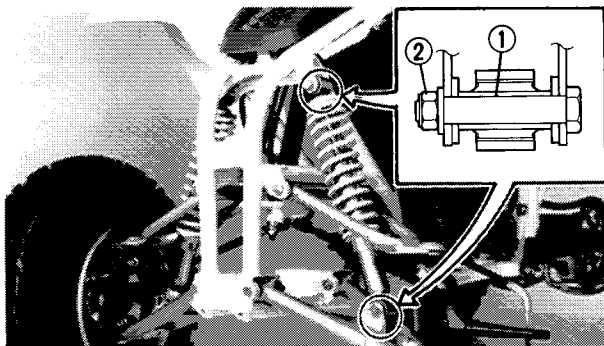

6. Lubricate:

- Bushings ① (Front shock absorber)

 **Lightweight Lithium-Soap Base Grease**

7. Tighten:

- Nuts (Front shock absorber ②)

 **Nut (Front Shock Absorber):**
45 Nm (4.5 m · kg, 33 ft · lb)

8. Tighten:

- Bolts (Front bumper ①)

 **Bolt (Front Bumper):**
26 Nm (2.6 m · kg, 19 ft · lb)

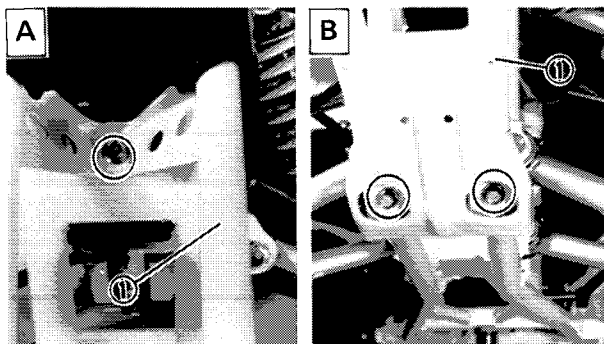

- A Upper
- B Lower

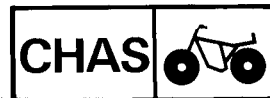

9. Install:

- Front brake assembly
- Front wheel

Refer to the "FRONT WHEEL AND FRONT BRAKE – INSTALLATION" section.

10. Adjust:

- Front shock absorber

Refer to the "FRONT AND REAR SHOCK ABSORBER ADJUSTMENT" section in the CHAPTER 3.

REAR SHOCK ABSORBER AND SWINGARM

- ① Rear shock absorber assembly
- ② Bushing
- ③ Cotter pin
- ④ Swingarm pivot shaft
- ⑤ Thrust cover
- ⑥ Plate washer
- ⑦ Dust cover
- ⑧ Bearing
- ⑨ Bushing
- ⑩ Oil seal
- ⑪ Inner collar
- ⑫ Swingarm
- ⑬ Protector guide
- ⑭ Thrust cover protector
- ⑮ Chain guide
- ⑯ Under guard
- ⑰ Shim (Left side only)

SPRING PRELOAD (INSTALLED LENGTH):	
STANDARD LENGTH:	230 mm (9.1 in)
MINIMUM LENGTH:	222 mm (8.7 in)
MAXIMUM LENGTH:	234 mm (9.2 in)

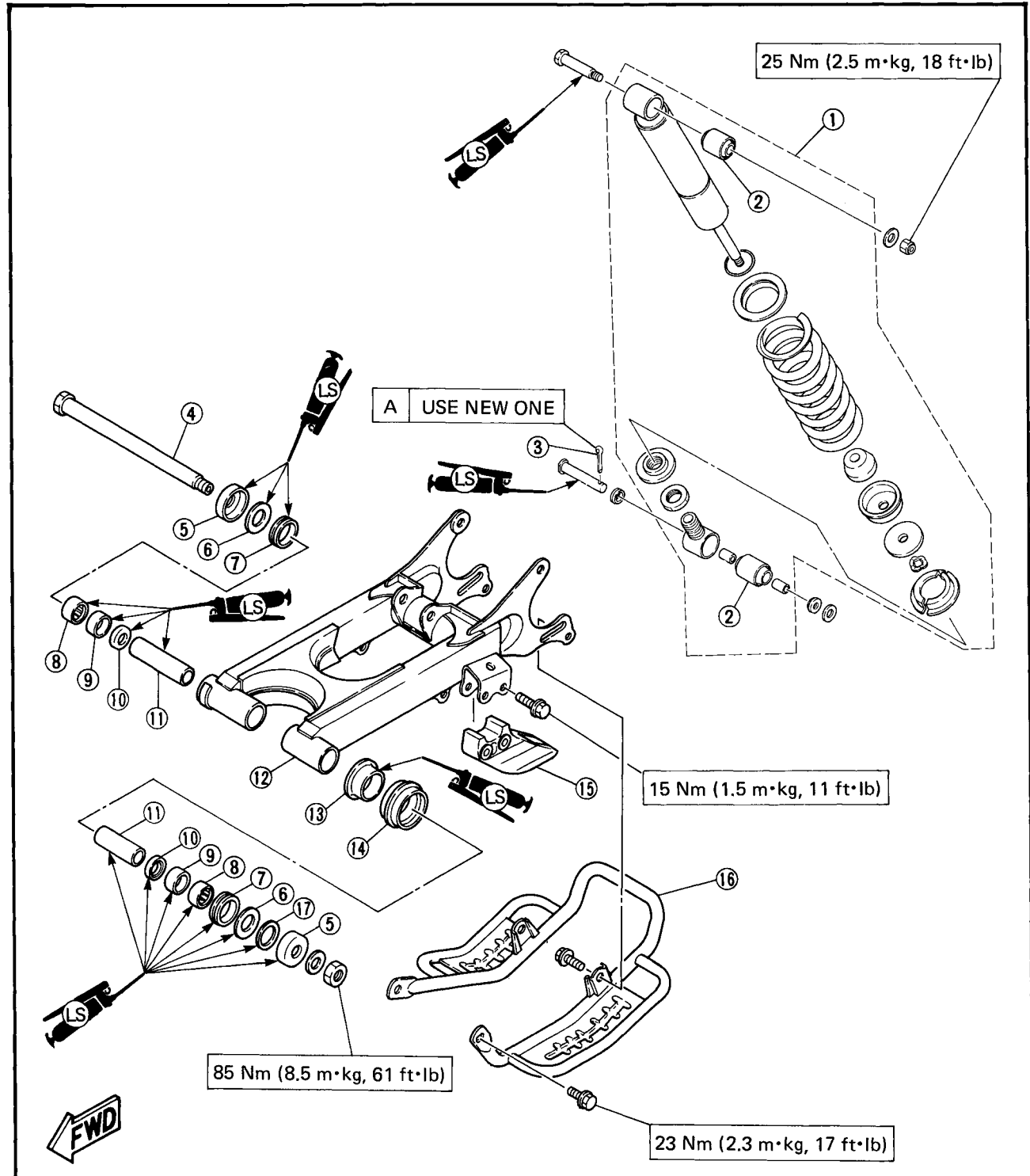

HANDLING NOTES

⚠ WARNING:

This shock absorber contains highly compressed nitrogen gas. Read and understand the following information before handling the shock absorber. The manufacturer cannot be held responsible for property damage or personal injury that may result from improper handling.

- Do not tamper or attempt to open the cylinder assembly.
- Do not subject shock absorber to an open flame or other high heat. This may cause the unit to explode due to excessive gas pressure.
- Do not deform or damage the cylinder in any way. Cylinder damage will result in poor damping performance.
- Take care not to scratch the contact surface of the piston rod with the cylinder; or oil could leak out.
- When scrapping the shock absorber, follow the "NOTES ON DISPOSAL".

6

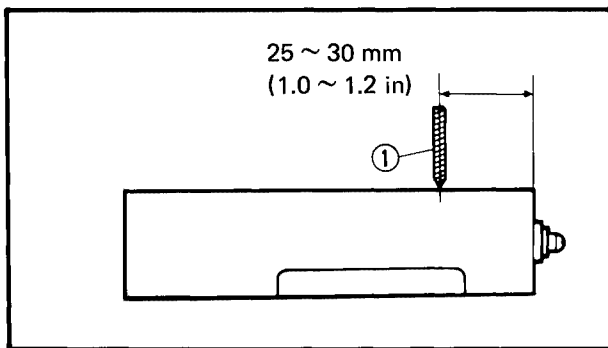

NOTES ON DISPOSAL

Shock absorber disposal steps:

Gas pressure must be released before disposing of shock absorber. To do so, drill ① a 2 ~ 3 mm (0.08 ~ 0.12 in) hole through the gas chamber wall at a point 25 ~ 30 mm (1.0 ~ 1.2 in) from the bottom end of the gas chamber.

⚠ CAUTION:

Wear eye protection to prevent eye damage from escaping gas and/or metal chips.

REMOVAL

1. Place the machine on a level place.
2. Elevate the rear wheels by placing the suitable stand under the rear of frame.

⚠ WARNING:

Securely support the machine so that it won't fall over.

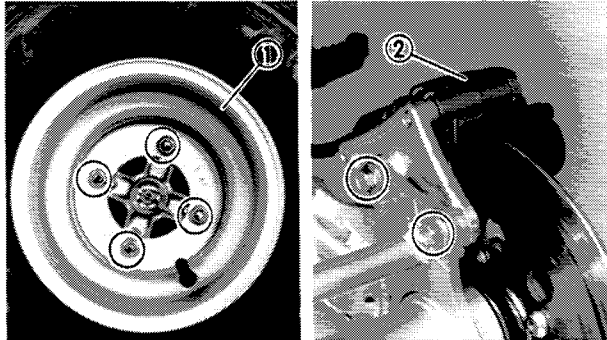

3. Remove:

- Rear wheels ①
- Brake caliper assembly ② (Rear)

NOTE:

Do not depress the parking brake lever and brake pedal when the brake caliper is off the disc otherwise the brake pads will be forced shut.

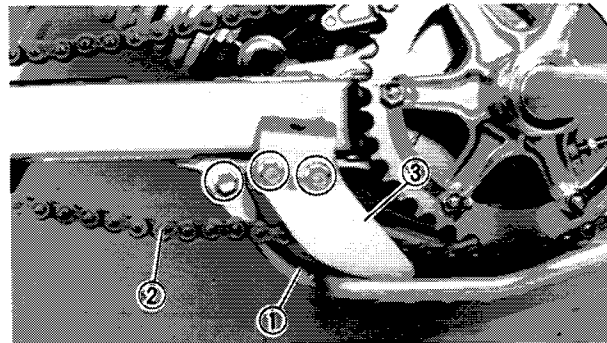

4. Remove:

- Under guard ①
- Chain assembly ②
- Chain guide ③

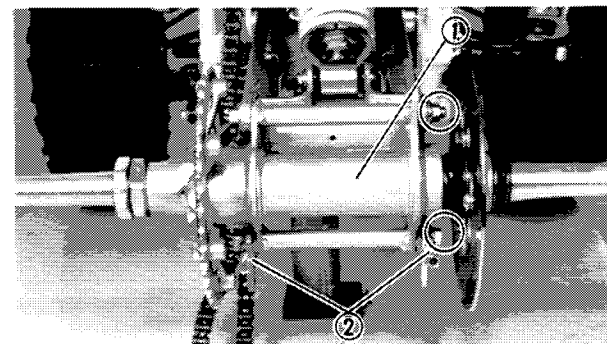

5. Remove:

- Rear axle hub ① (with rear axle)
- Chain tensioner ②

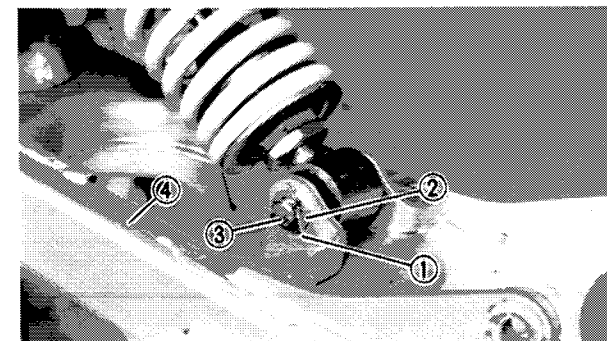

6. Remove:

- Cotter pin ①
- Washer ②
- Shaft ③

NOTE:

When removing the lower shaft ③, hold the swingarm ④ so that it does not drop downwards when the shaft is removed.

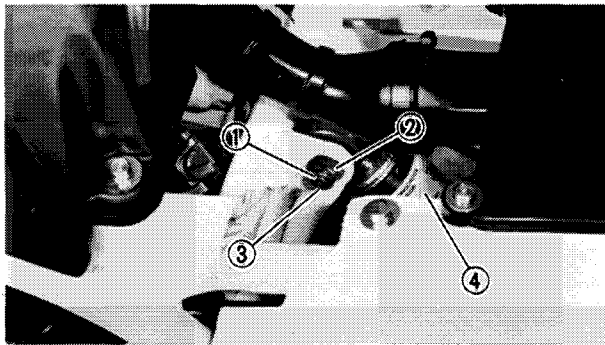

7. Remove:
- Seat
 - Nut ① (Shock absorber – Upper)
 - Washer ②
 - Bolt ③ (Shock absorber – Upper)
 - Shock absorber ④ (Rear)

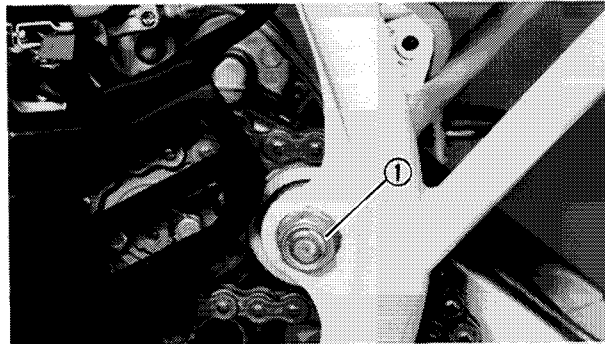

8. Check:
- Swingarm free play

Swingarm free play inspection steps:

- Check the tightening torque of the pivot shaft (swing arm) securing nut ① .



Nut (Swingarm-Pivot Shaft):
85 Nm (8.5 m·kg, 61 ft·lb)

- Check the swingarm side play **A** by moving it from side to side.
If side play noticeable, check the inner collar, bearing, bushing and thrust cover, or adjust the shim.
- Check the swingarm vertical movement **B** by moving it up and down.
If vertical movement is tight, binding or rough, check the inner collar, bearing, bushing and thrust cover, or adjust the shim.

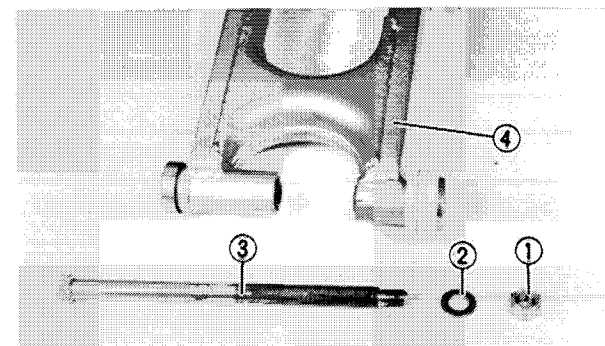
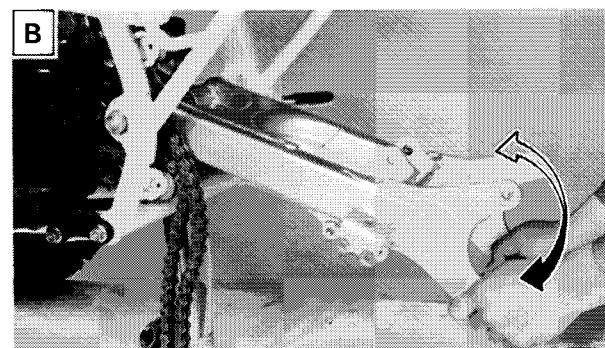
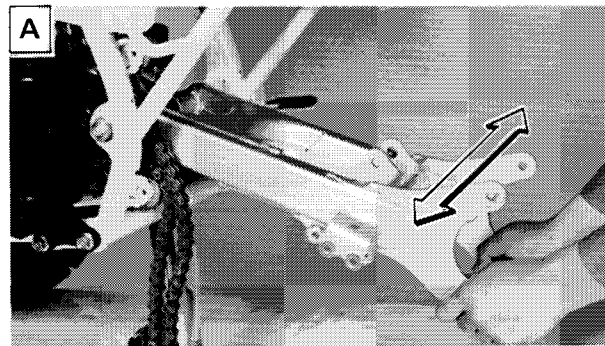

9. Remove:
- Nut ① (Swingarm – Pivot shaft)
 - Washer ②
 - Pivot shaft ③ (Swingarm)
 - Swingarm ④

6

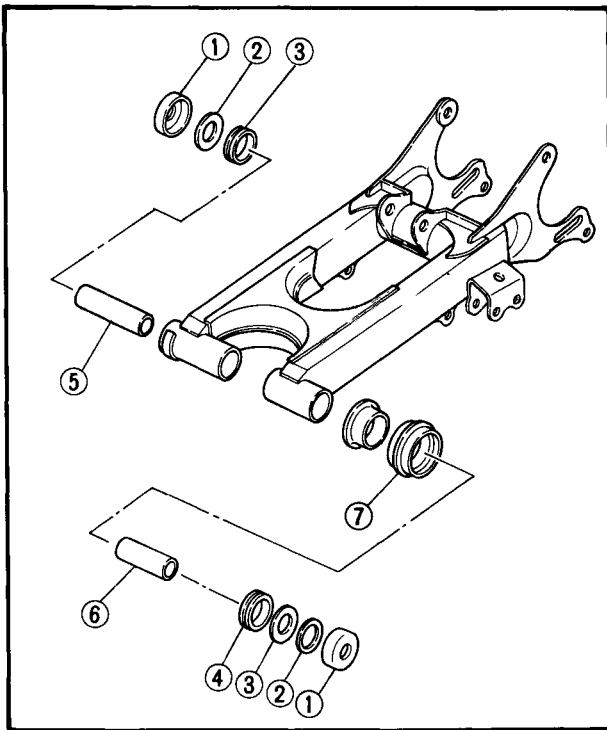

10. Remove:
- Thrust covers ①
 - Shim ② (Left side only)
 - Washers ③
 - Dust covers ④
 - Inner collars (Right ⑤ and Left ⑥)
 - Protector ⑦ (Thrust cover – Left)

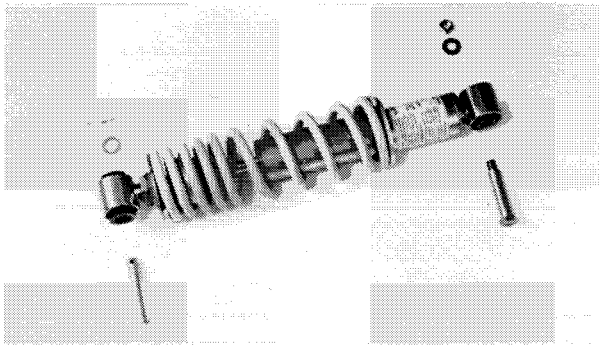

INSPECTION

1. Inspect:
- Shock absorber rod
Bends/Damage → Replace the shock absorber assembly.
2. Inspect:
- Shock absorber
Oil leaks/Gas leaks → Replace the shock absorber assembly.
 - Spring
Fatigue → Replace the shock absorber assembly.
Move the spring up and down.

6

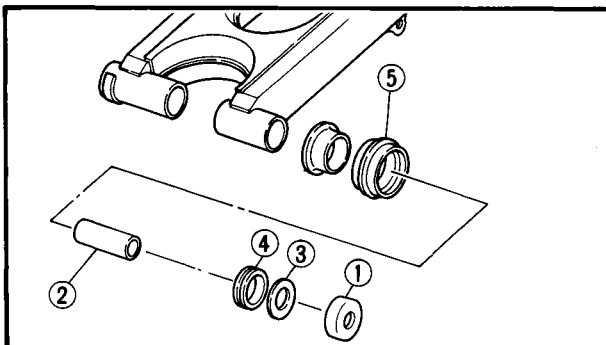

3. Inspect:
- Thrust cover ①
Wear/Damage → Replace.
 - Inner collar ②
 - Washer ③
Damage → Replace.
 - Dust cover ④
 - Protector ⑤ (Thrust cover)

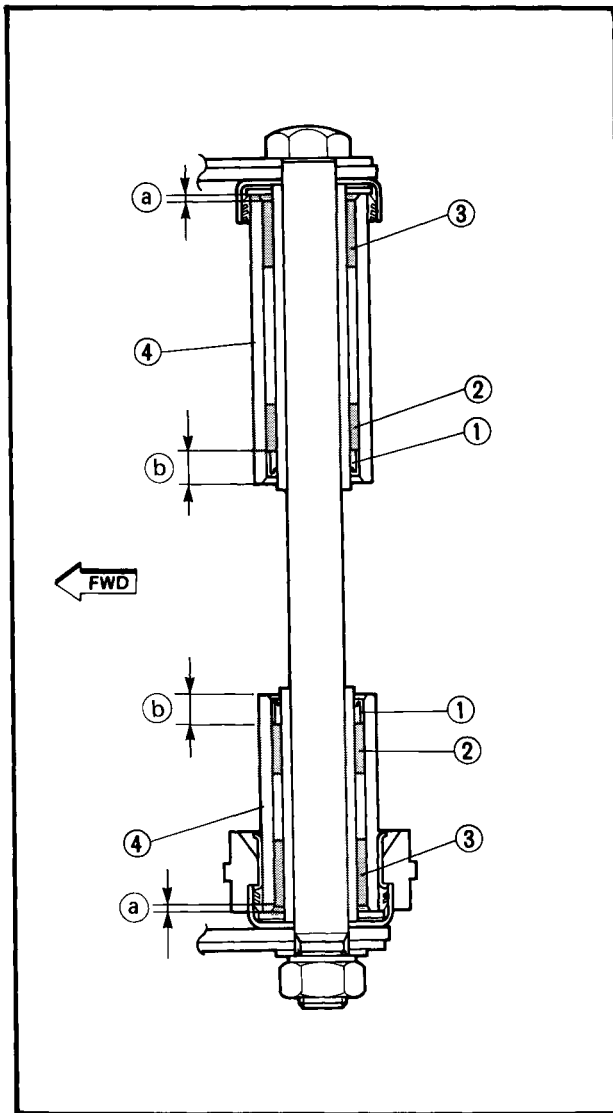

4. Inspect:

- Oil seals ①
Damage → Replace.
- Bushings ②
Scratches/Damage → Replace.
- Bearings ③
Turns roughly → Replace.

NOTE:

When fitting the bearings ③ and bushings ② into the swingarm ④, be sure to do so at the position as specified in the figure.

- ① 2.0 mm (0.079 in)
- ② 10.0 mm (0.394 in)

5. Inspect:

- Swingarm
Crack/Bend/Damage → Replace.

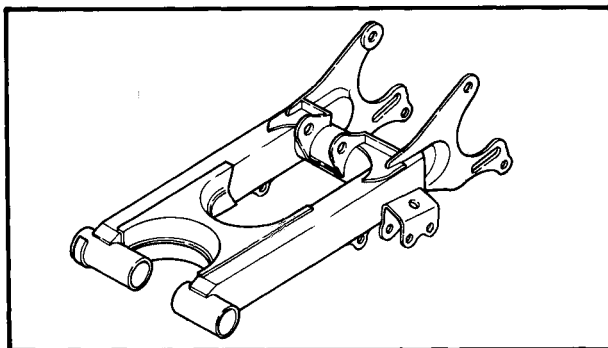

6. Inspect:

- Pivot shaft ①
Roll the axle on a flat surface.
Bends → Replace.

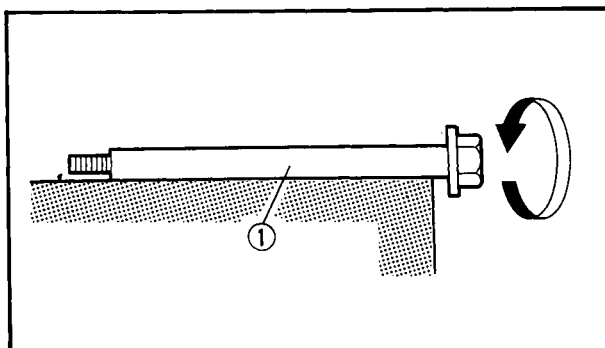

⚠ WARNING:

Do not attempt to straighten a bent axle.

6

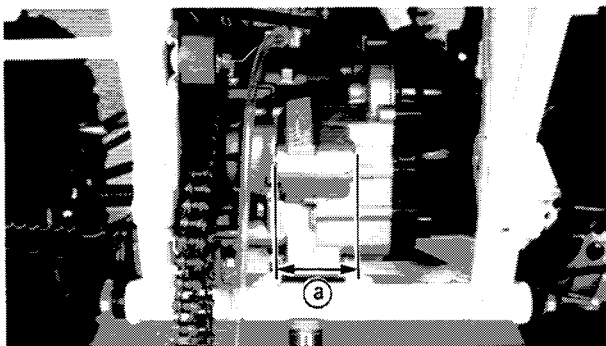

SIDE CLEARANCE ADJUSTMENT

1. Measure:

- Engine mounting boss width (a)

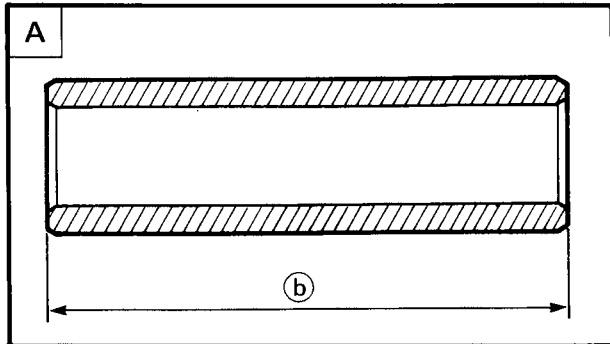

2. Measure:

- Inner collar length (b) and (c)
Out of specification → Replace.



Inner Collar Length:
 (b) = 91.30 ~ 91.45 mm
 (3.594 ~ 3.600 in)
 (c) = 69.30 ~ 69.45 mm
 (2.728 ~ 2.734 in)

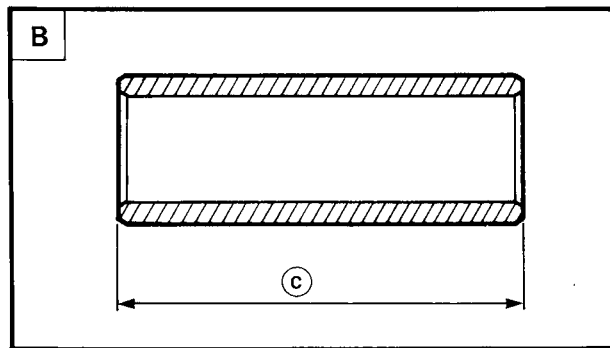

- [A] Right-side inner collar
- [B] Left-side inner collar

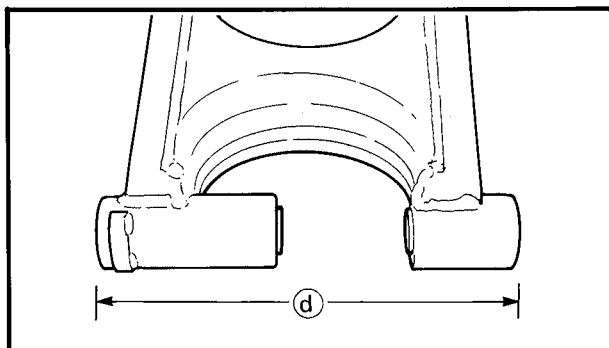

3. Measure:

- Pivot width (d) (Swingarm)

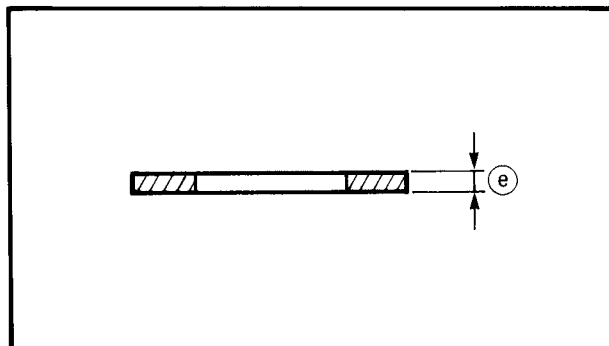

4. Measure:

- Washer thickness (e)
Out of specification → Replace.



Washer Thickness:
 2.00 ~ 2.10 mm (0.079 ~ 0.083 in)

5. Calculate:

- Swingarm side clearance

Out of specification → Adjust side clearance using shim.

By using formula given below.

Side Clearance:

$$= (a + b + c) - (d + e \times 2)$$

 **Side Clearance:**
 0.4 ~ 0.7 mm (0.016 ~ 0.028 in)

Example:

a. If the engine mounting boss width (a) , inner collar length (b) and (c) are below.

- (a) = 59.68 mm (2.350 in)
- (b) = 91.35 mm (3.596 in)
- (c) = 69.35 mm (2.730 in)

b. If the pivot width d and washer thickness (e) are below.

- (d) = 215.5 mm (8.484 in)
- (e) = 2.00 mm (0.079 in)

Side clearance

$$= (59.68 + 91.35 + 69.35) - (215.5 + 2.00 \times 2) = 0.88 \text{ mm (0.035 in)}$$

Then, install the one shim.

NOTE: _____
 When installing the shim on the left side only.

 **Shim Thickness:**
 0.3 mm (0.012 in)

6

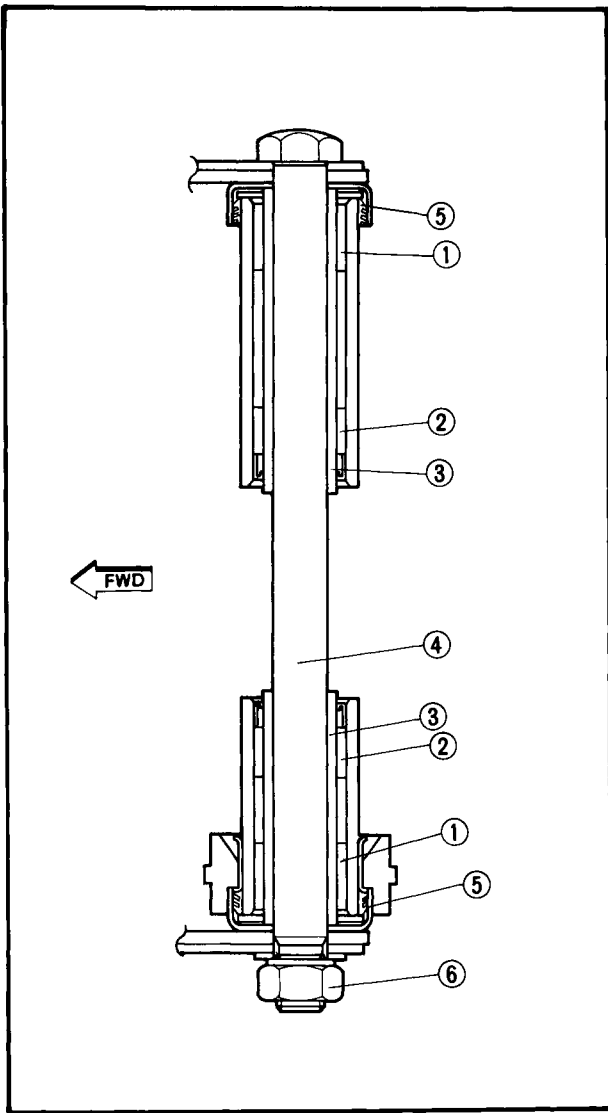

INSTALLATION

Reverse the "REMOVAL" procedure.
Note the following points.

1. Lubricate:
 - Bearings ①
 - Bushings ② (Inner surface)
 - Inner collars ③
 - Pivot shaft ④ (Outer surface)
 - Dust cover ⑤ (Lips)

 **Lightweight Lithium-Soap Base Grease**

2. Tighten:
 - Nut ⑥ (Swingarm – Pivot shaft)

 **Nut (Swingarm – Pivot Shaft):
85 Nm (8.5 m · kg, 61 ft · lb)**

3. Check:
 - Swingarm (Side play)
 - Swingarm (Vertical movement)

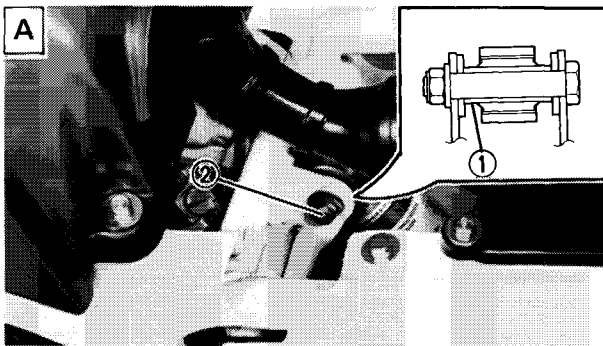

4. Lubricate:
 - Bushings ① (Shock absorber)

 **Lightweight Lithium – Soap Base Grease**

5. Install:
 - Shock absorber

 **Nut ② (Shock Absorber – Upper):
25 Nm (2.5 m · kg, 17 ft · lb)**

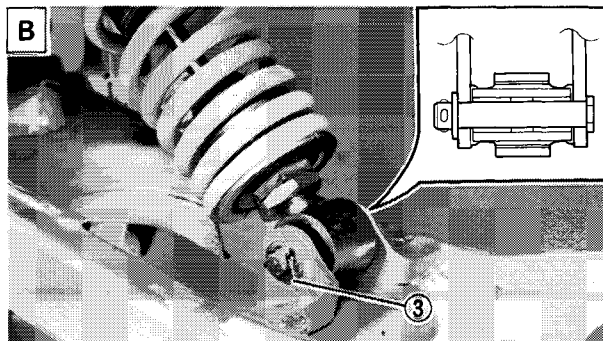

6. Install:
 - Cotter pin ③

⚠ WARNING:

Always use a new cotter pin.

- A** Upper side
- B** Lower side

7. Install:

- Chain tensioner
- Rear axle hub (with rear axle)
- Chain guide
- Chain assembly
- Under guard
- Brake caliper assembly (Rear)
- Rear wheel

Refer to the "REAR WHEEL AND REAR AXLE" and "DRIVE CHAIN AND SPROCKET" sections.

8. Adjust:

- Drive chain slack

Refer to the "DRIVE CHAIN SLACK ADJUSTMENT" section in the CHAPTER 3.

9. Adjust:

- Rear shock absorber

Refer to the "REAR SHOCK ABSORBER ADJUSTMENT" section in the CHAPTER 3.



DRIVE CHAIN AND SPROCKET

NOTE:

Before removing the drive chain and sprockets, drive chain slack and 10-link length of drive chain should be measured.

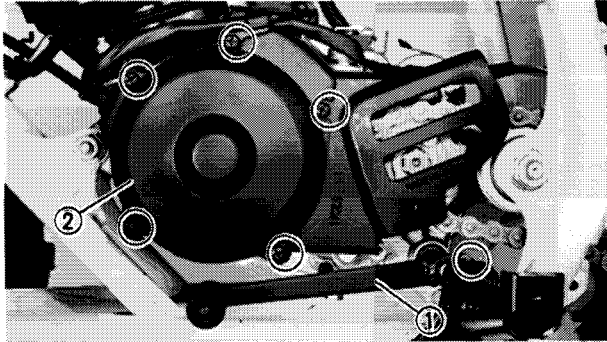

REMOVAL

1. Remove:

- Change pedal ①
- Crankcase cover ② (Left)

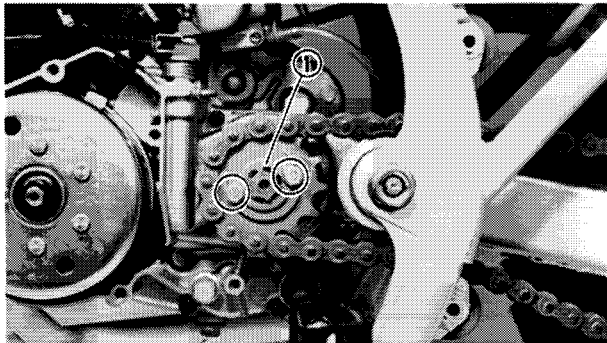

2. Remove:

- Holder ① (Drive sprocket)

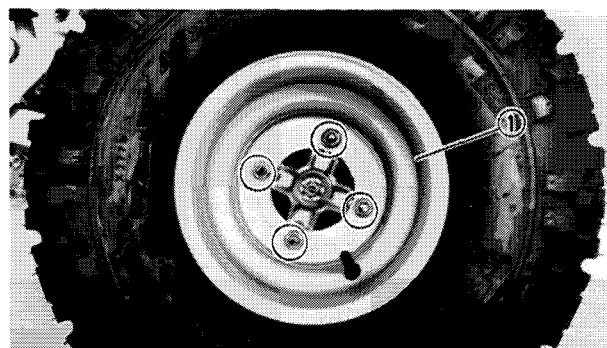

3. Loosen:

- Nuts (Rear wheel ① – Left)

4. Elevate the rear wheels by placing the suitable stand under the rear frame.

5. Remove:

- Rear wheel ① (Left)

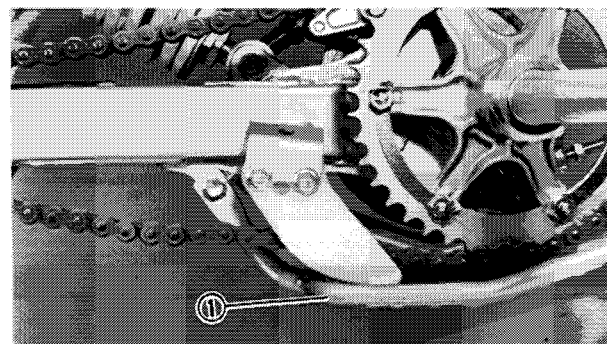

6. Remove:

- Under guard ①

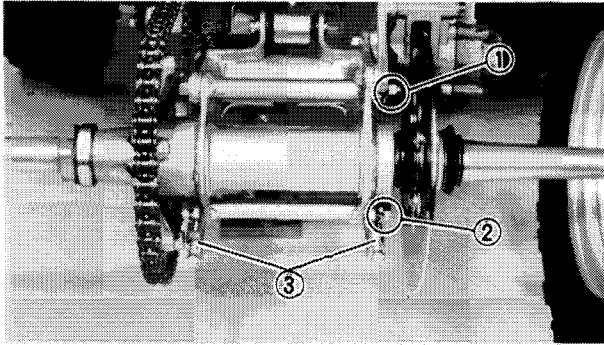

7. Loosen:
- Nut ① (Rear axle hub – Upper)
 - Nut ② (Rear axle hub – Lower)
8. Loosen:
- Adjusters ③ (Chain tensioner)

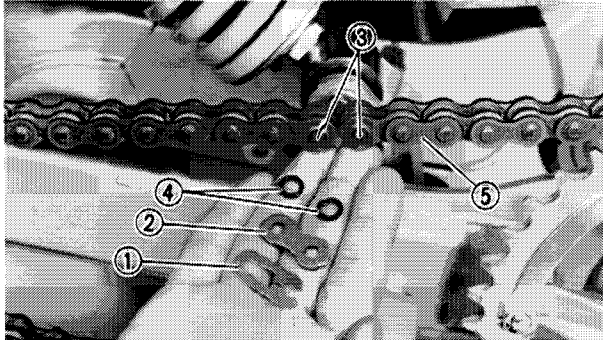

9. Remove:
- Clip ① (Master link)
 - Plate ② (Master link)
 - Master link ③
 - O-rings ④
 - Drive chain ⑤

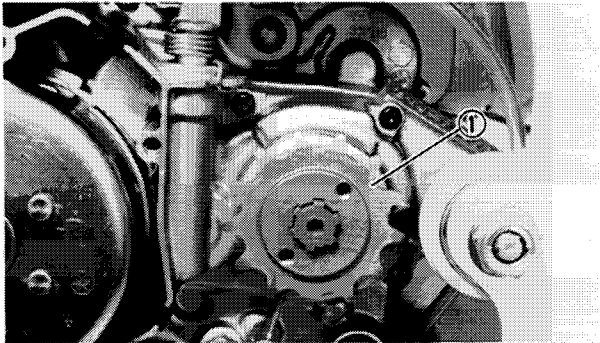

10. Remove:
- Drive sprocket ①

6

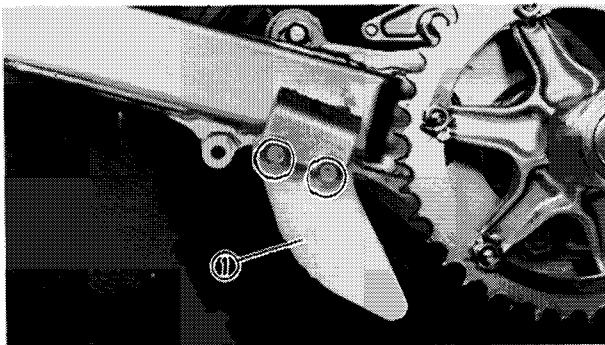

11. Remove:
- Chain guide ①

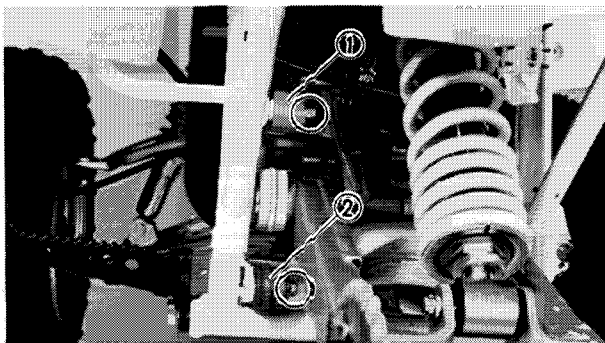

12. Remove:
- Chain guide rollers (Upper ① and lower ②)

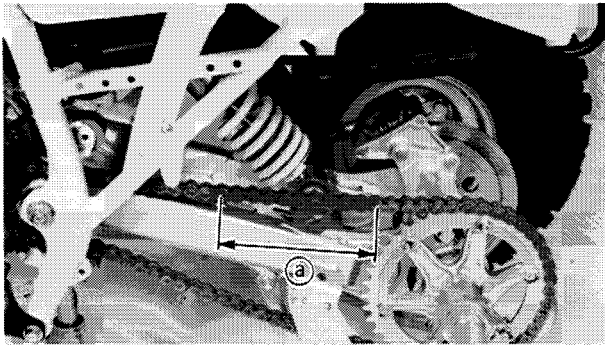

INSPECTION

1. Measure:

- 10-link length (a) (Drive chain)
Out of specification → Replace drive chain.



10-Link Length Limit:
150.1 mm (5.91 in)

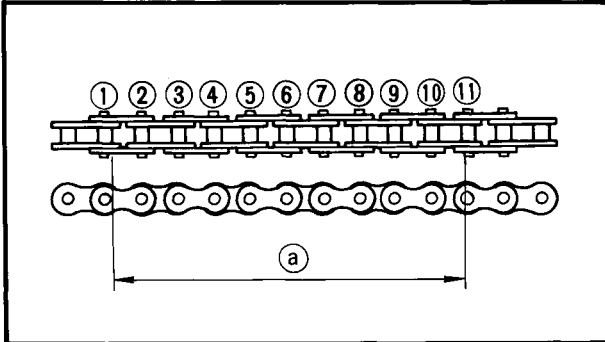

NOTE:

- For measurement make the chain tense by finger.
- 10-link length is a measurement between the insides of the ① and ⑪ rollers as shown.
- Two or three different 10-link lengths should be measured.

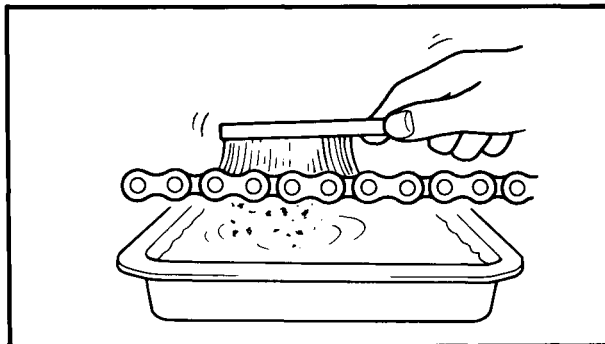

2. Clean:

- Drive chain
Place it in kerosene, and brush off as much dirt as possible. Then remove the chain from the kerosene and dry the chain.

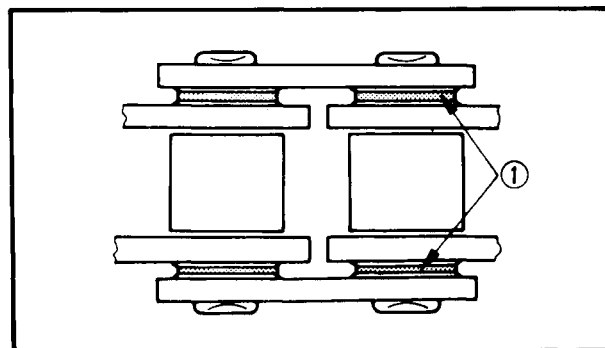

CAUTION:

This machine has a drive chain with small rubber O-rings ① between the chain plates. Steam cleaning, high-pressure washes, and certain solvent can damage these O-rings. Use only kerosene to clean the drive chain.

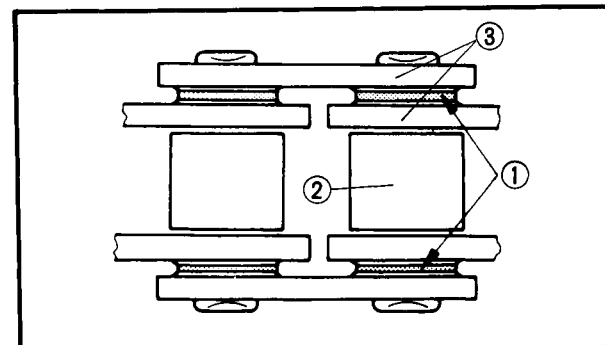

3. Inspect:

- O-rings ① (Drive Chain)
Damage → Replace drive chain.
- Rollers ②
- Side plates ③
Damage/Wear → Replace drive chain.



4. Lubricate:
- Drive chain



Drive Chain Lubricant:
SAE 30 ~ 50 Motor oil

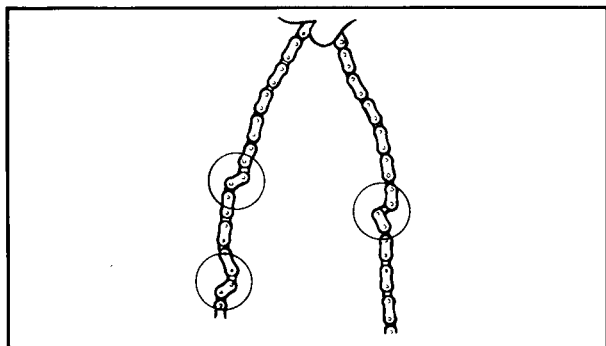

5. Inspect:
- Drive chain stiffness
- Stiff → Clean and lubricate or replace.

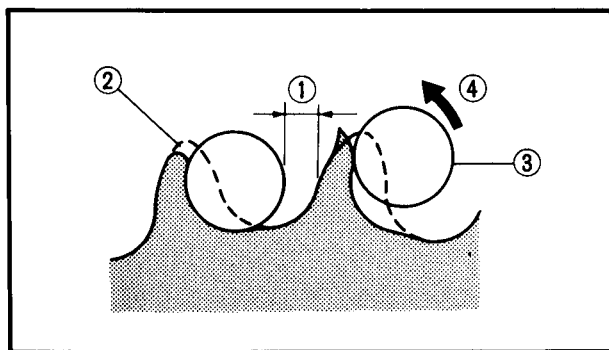

6. Inspect:
- Drive sprocket
 - Driven sprocket
- More than 1/4 teeth ① wear → Replace sprocket.
Bent teeth → Replace sprocket.

6

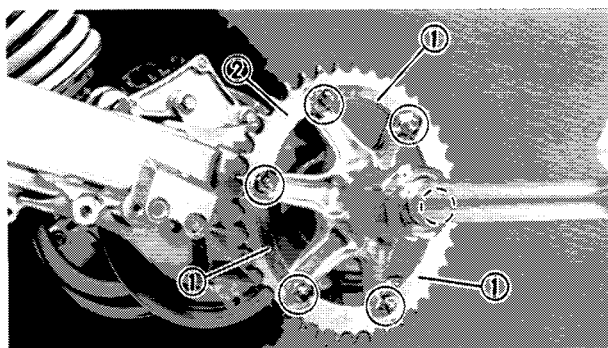

Driven sprocket replacement steps:

- Straighten the lock washer ① tabs and remove the driven sprocket ② .
- Install a new driven sprocket and lock washers.

⚠ WARNING:

Always use a new lock washers.



Nuts (Driven Sprocket):
24 Nm (2.4 m · kg, 17 ft · lb)

- Bend the lock washer tabs along the nut flats.

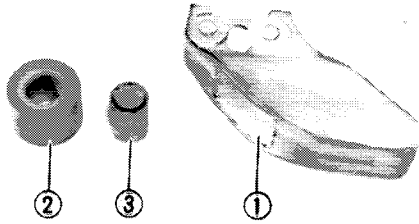

7. Inspect:
- Chain guide ①
 - Chain guide rollers ②
 - Collars ③ (Guide roller)
- Wear/Damage → Replace.

INSTALLATION

Reverse the "REMOVAL" procedure.

Note the following points.

1. Lubricate:
- Collars (Inner surface)



Molybdenum Disulfide Grease

2. Tighten:
- Bolts (Chain guide rollers)



Bolt (Chain Guide Roller):
9 Nm (0.9 m · kg, 6.8 ft · lb)

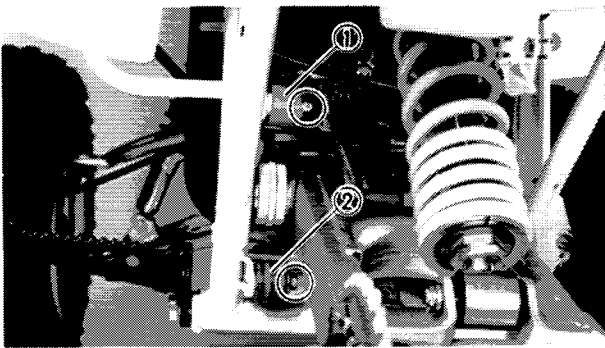

- ① Upper
② Lower

3. Install:
- Drive chain

NOTE: _____
During reassembly, the master link clip ① must be installed with the rounded end facing the direction of travel.

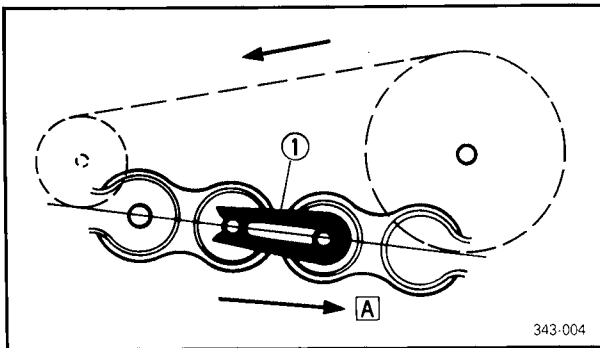

- A** Turning direction

4. Tighten:
- Bolts (Under guard)
 - Nuts (Rear wheel)
 - Bolts (Drive sprocket holder)
 - Screws (Crankcase cover – Left)
 - Bolts (Change pedal)



Bolt (Under Guard):
23 Nm (2.3 m · kg, 17 ft · lb)

Nut (Rear Wheel):
45 Nm (4.5 m · kg, 33 ft · lb)

Bolt (Drive Sprocket Holder):
10 Nm (1.0 m · kg, 7.2 ft · lb)

Screw (Crankcase Cover – Left):
10 Nm (1.0 m · kg, 7.2 ft · lb)

Bolt (Change Pedal):
14 Nm (1.4 m · kg, 10 ft · lb)

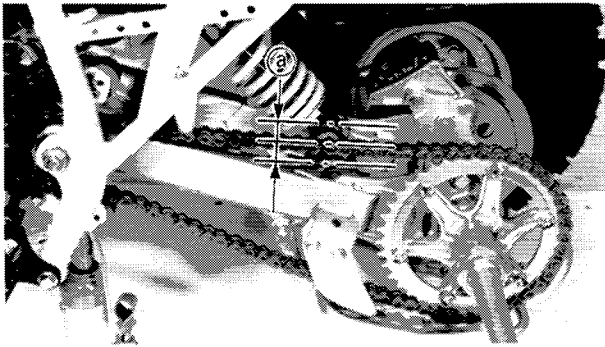

5. Adjust:

- Drive chain slack (a)

Refer to the "DRIVE CHAIN – SLACK ADJUSTMENT" section in the CHAPTER 3.



Drive Chain Slack:
30 ~ 40 mm (1.18 ~ 1.57 in)

6

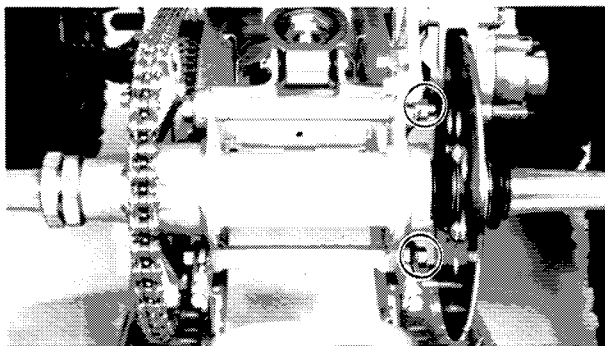

6. Tighten:

- Nut (Rear axle hub – Upper)
- Nut (Rear axle hub – Lower)



Nut (Rear Axle Hub – Upper and Lower):
50 Nm (5.0 m · kg, 36 ft · lb)



ELECTRICAL

YFS200U CIRCUIT DIAGRAM

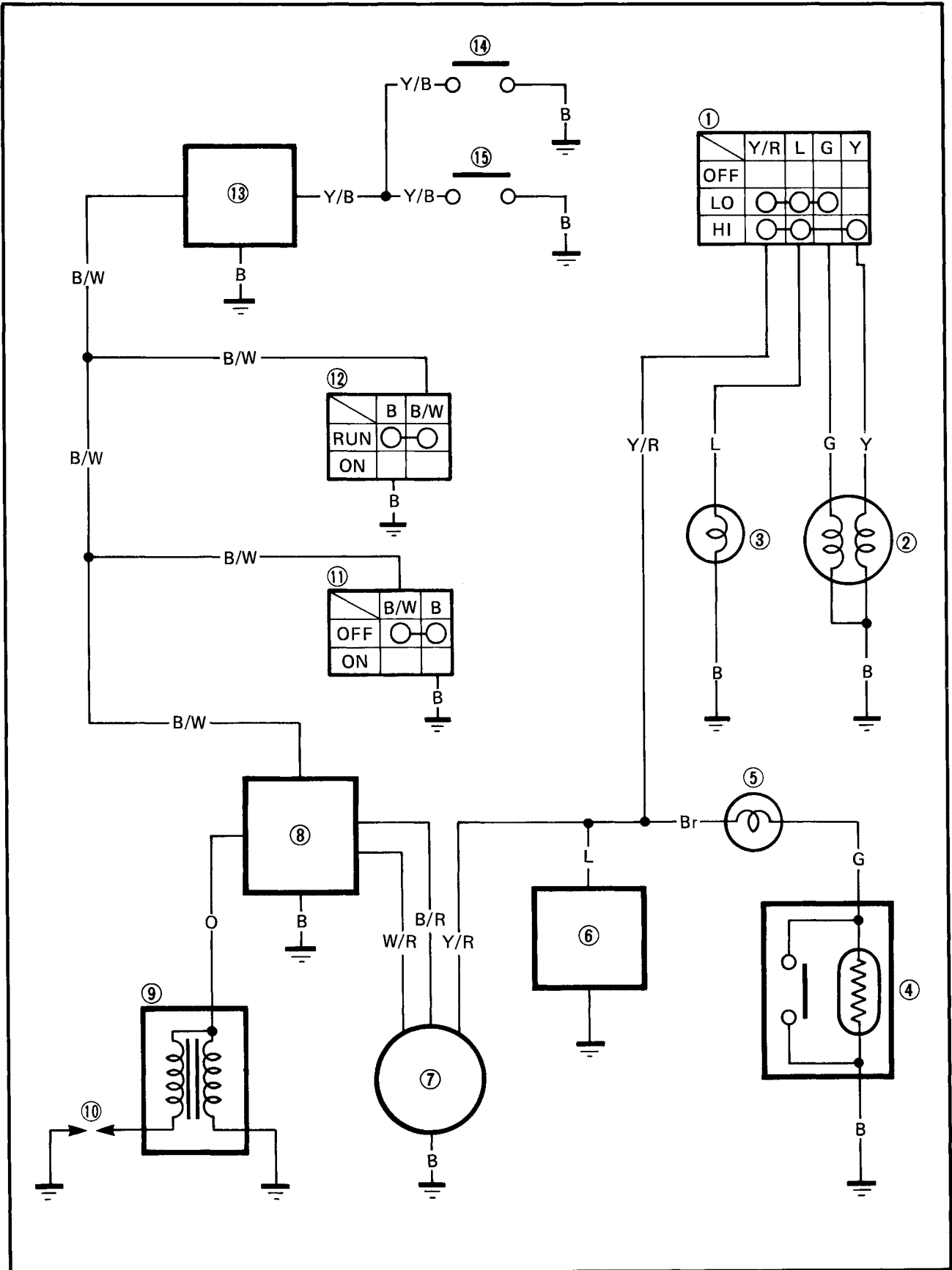

7



- ① "LIGHTS" (Dimmer) switch
- ② Headlight
- ③ Taillight
- ④ Oil level gauge
- ⑤ "OIL" indicator light
- ⑥ Voltage regulator
- ⑦ CDI magneto
- ⑧ CDI unit
- ⑨ Ignition coil
- ⑩ Spark plug
- ⑪ Main switch
- ⑫ "ENGINE STOP" switch
- ⑬ Control unit
- ⑭ Carburetor switch
- ⑮ Throttle switch

COLOR CODE

- | | |
|---------------|-----------------------|
| B..... Black | B/R..... Black/Red |
| Br..... Brown | B/W..... Black/White |
| G..... Green | W/R..... White/Red |
| L..... Blue | Y/B..... Yellow/Black |
| O..... Orange | Y/R..... Yellow/Red |
| Y..... Yellow | |

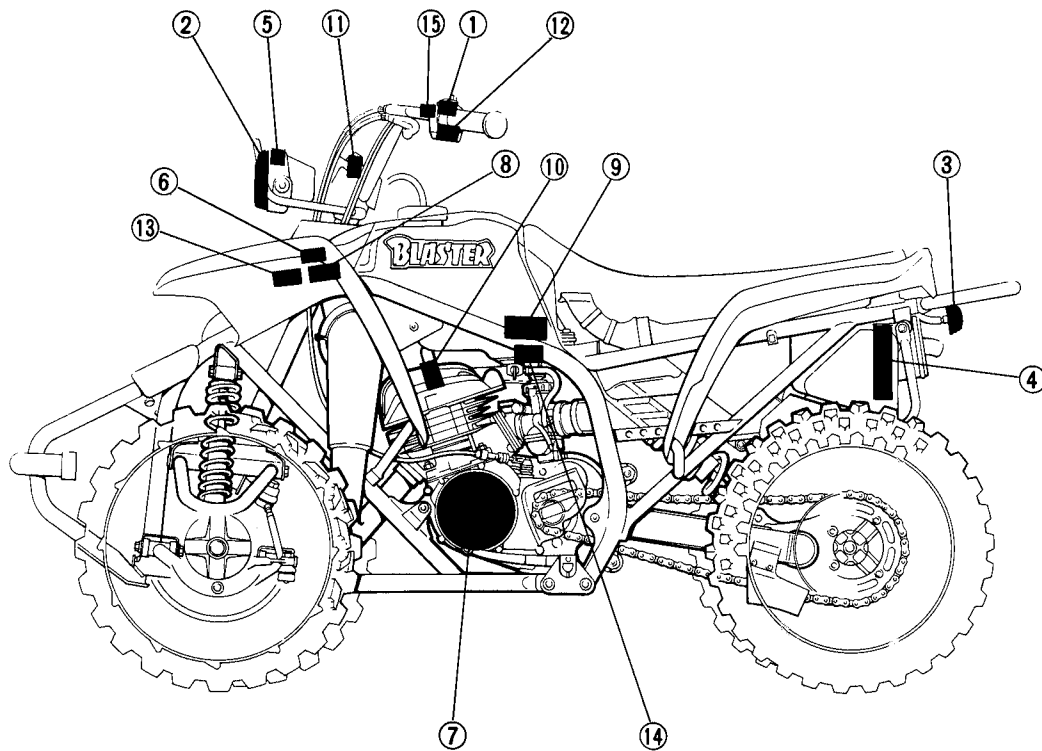



ELECTRICAL COMPONENTS

- ① Wireharness
- ② Oil level gauge
- ③ Ignition coil
- ④ Control unit
- ⑤ CDI unit
- ⑥ Voltage regulator
- ⑦ Main switch
- ⑧ "OIL" indicator light

IGNITION COIL:

PRIMARY COIL RESISTANCE:

1.44 ~ 1.76Ω at 20°C (68°F)

SECONDARY COIL RESISTANCE:

5.28 ~ 7.92kΩ at 20°C (68°F)

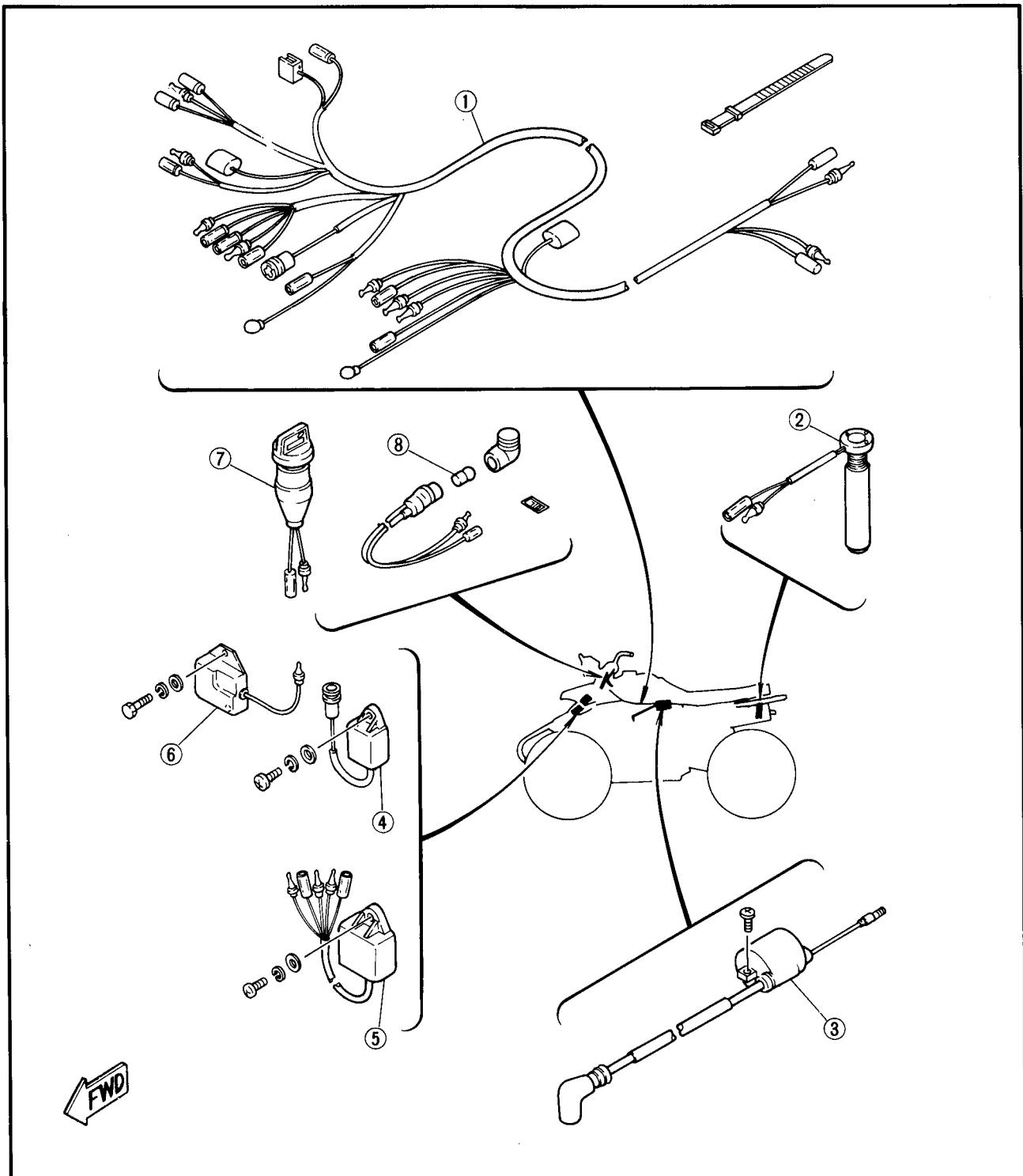

7



IGNITION SYSTEM

CIRCUIT DIAGRAM

Below circuit diagram shows ignition system.

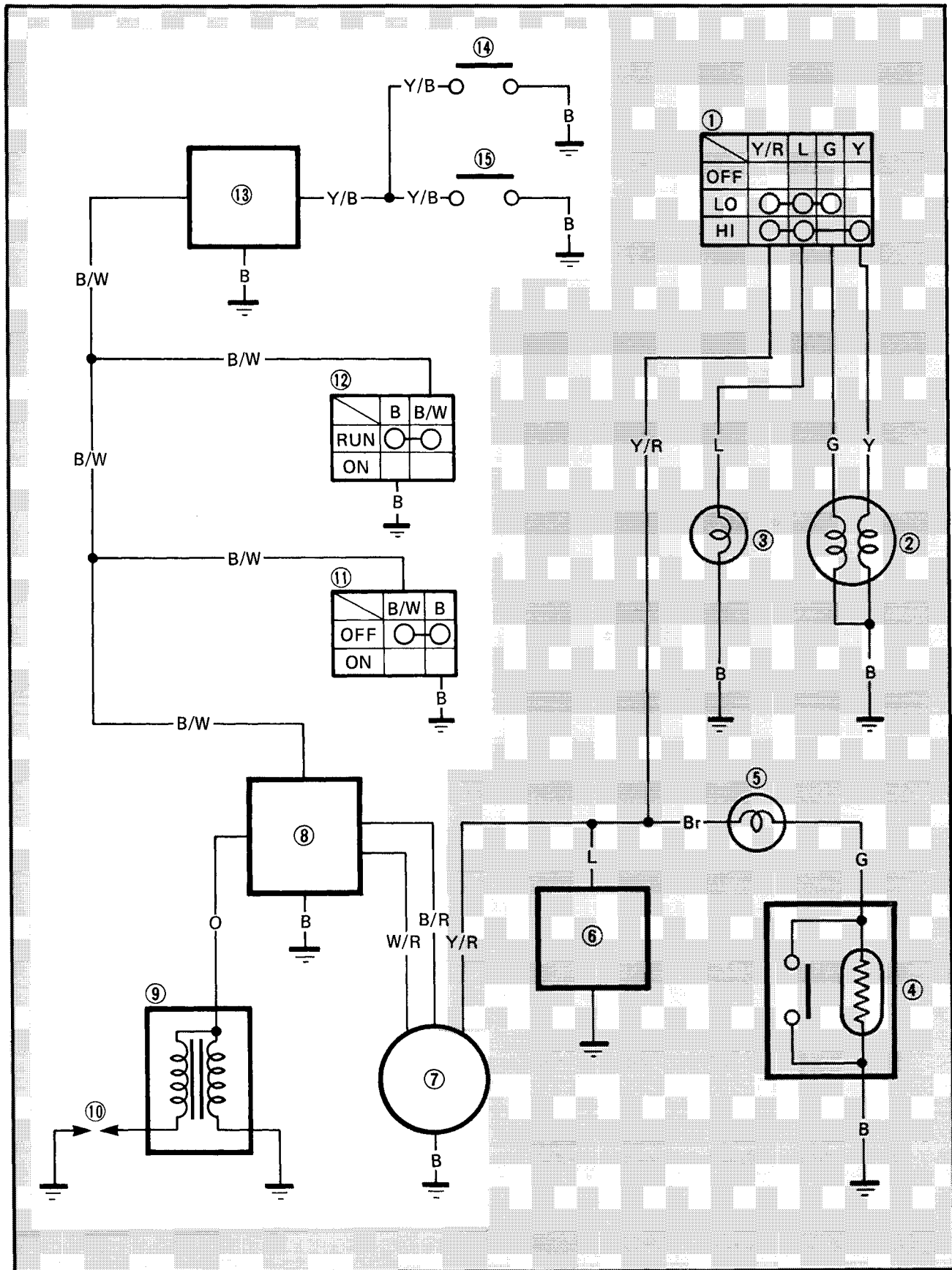

7

**NOTE:**

For the color codes, see page 7-2.

- ⑦ CDI magneto
- ⑧ CDI unit
- ⑨ Ignition coil
- ⑩ Spark plug
- ⑪ Main switch
- ⑫ "ENGINE STOP" switch
- ⑬ Control unit
- ⑭ Carburetor switch
- ⑮ Throttle switch

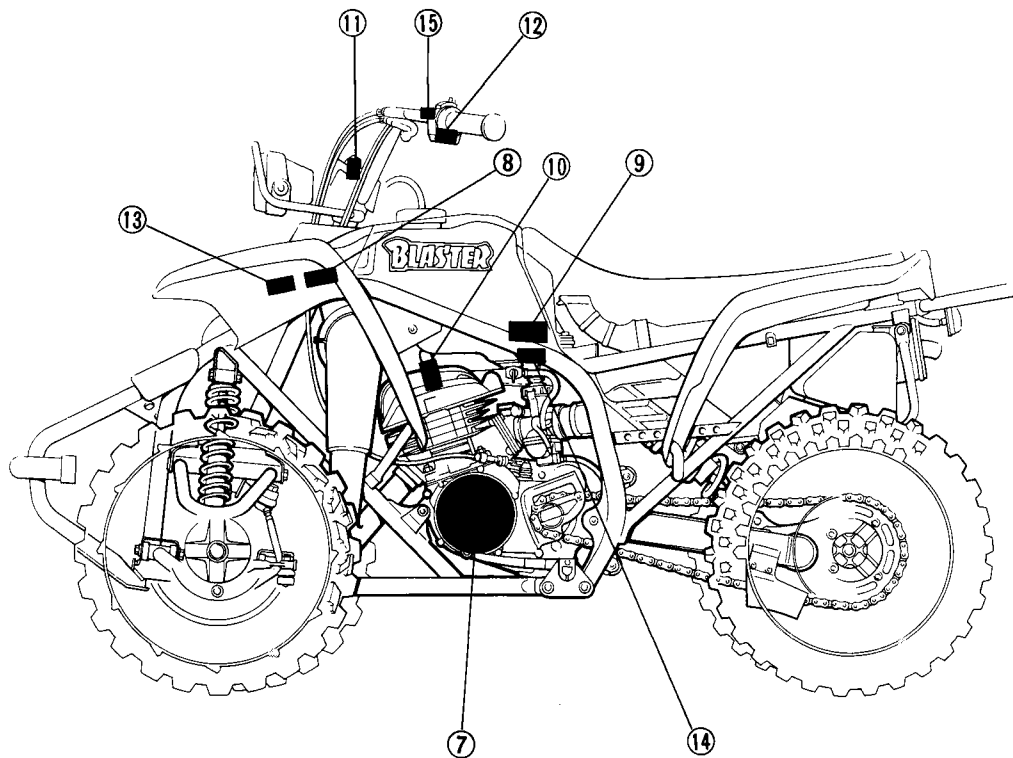
**7**



TROUBLESHOOTING

IF IGNITION SYSTEM SHOULD BECOME INOPERATIVE (NO SPARK OR INTERMITTENT SPARK).

Procedure (1)

Check;

- | | |
|------------------------------|--|
| 1. Ignition system | 6. "ENGINE STOP" switch conduct |
| 2. Spark plug | 7. Ignition coil resistance |
| 3. Ignition spark gap | 8. Source coil resistance |
| 4. Spark plug cap resistance | 9. Pickup coil resistance |
| 5. Main switch conduct | 10. Wiring connection (Entire ignition system) |

NOTE:

Remove the following parts before troubleshooting.

- | | |
|----------------------------|---------------------------|
| 1) Fuel tank cover (Front) | 3) Fuel tank cover (Rear) |
| 2) Seat | 4) Fuel tank |

Use the following special tools in this troubleshooting.



Dynamic Spark Tester:
P/N. YM-34487
P/N. 90890-03144



Pocket Tester:
P/N. YU-03112
P/N. 90890-03112

1. Ignition system

- Disconnect the control unit coupler ① (Black/White, Yellow/Black and Black) from the wireharness.
- Start the engine.

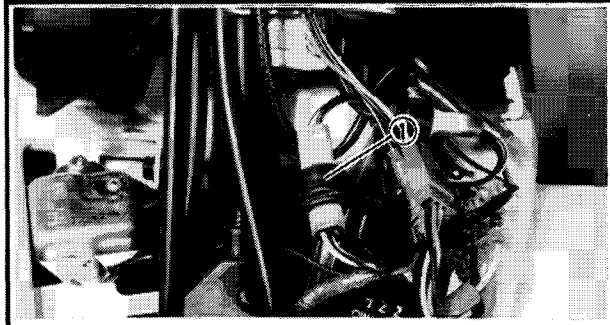

ENGINE STARTS.

Go to "Procedure (2)".

ENGINE DOES NOT START.

*

7



2. Spark plug

- Check the spark plug condition, type and gap. Refer to "CHAPTER 3. SPARK PLUG INSPECTION" section.

Standard Spark Plug:
 For USA and Oceania:
 B8ES (NGK), W24ES (N.D.)
 For Canada and S. Africa:
 BP8ES (NGK)

 **Spark Plug Gap:**
 0.7 ~ 0.8 mm (0.028 ~ 0.032 in)

INCORRECT

Repair or replace spark plug.



3. Ignition spark gap

- Disconnect the spark plug cap from spark plug.
- Connect the Dynamic Spark Tester ① as shown.

② Spark plug cap
 ③ Spark plug

- Turn the main switch to "ON".
- Kick the kick crank.

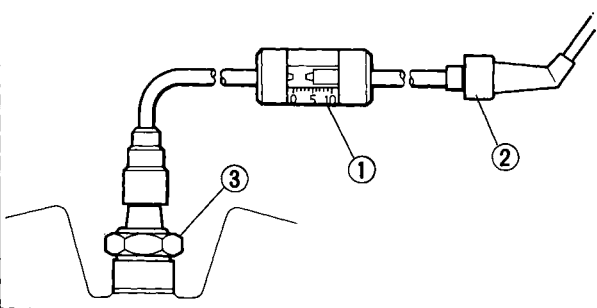

- Check the ignition spark gap.
- Start engine, and increase spark gap until misfire occurs.

 **Minimum Spark Gap:**
 6.0 mm (0.24 in)

MEETS SPECIFICATION

Ignition system is good.

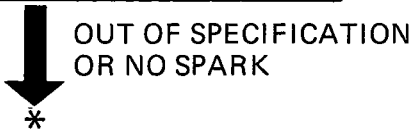

7



4. Spark plug cap resistance

- Remove the spark plug cap.
- Connect the Pocket Tester ($\Omega \times 1k$) to the spark plug cap.

- Check the spark plug cap for specified resistance.

Spark Plug Cap Resistance:
4 ~ 6k Ω at 20°C (68°F)

OUT OF SPECIFICATION

Spark plug cap is faulty, replace it.

MEETS SPECIFICATION

5. Main switch conduct

- Disconnect the main switch leads ①.
- Connect the Pocket Tester ($\Omega \times 1$) to the main switch leads.

Tester (+) Lead → Black/White ② Lead
Tester (-) Lead → Black ③ Lead

- Turn the main switch to "ON" and "OFF".
- Check the main switch for continuity.

Switch position	Good condition	Bad condition		
OFF	○	X	X	○
ON	X	○	X	○

○ : Continuity X : Nocontinuity

BAD CONDITION

Main switch is faulty, replace it.

GOOD CONDITION

7



6. "ENGINE STOP" switch conduct

- Disconnect the "ENGINE STOP" switch leads ①.
- Connect the Pocket Tester ($\Omega \times 1$) to the "ENGINE STOP" switch leads.

Tester (+) Lead → Black/White ② Lead
Tester (-) Lead → Black ③ Lead

- Turn the "ENGINE STOP" switch to "OFF" and "RUN".
- Check the "ENGINE STOP" switch for continuity.

Switch position	Good condition	Bad condition		
RUN	X	○	X	○
OFF	○	X	X	○

○ : Continuity X : Nocontinuity

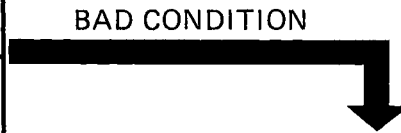

"ENGINE STOP" switch is faulty, replace handlebar switch (Left).

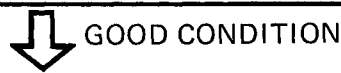

7. Ignition coil resistance

- Disconnect the ignition coil leads (Orange and Black).
- Remove the ignition coil.
- Connect the Pocket Tester ($\Omega \times 1$) to the ignition coil.

Tester (+) Lead → Orange ① Lead
Tester (-) Lead → Ground ② Terminal

7



- Check the primary coil for specified resistance.



Primary Coil Resistance:
1.44 ~ 1.76Ω at 20°C (68° F)

- Connect the Pocket Tester (Ω x 1K) to the ignition coil.

Tester (+) Lead → Spark Plug Lead ①
Tester (-) Lead → Orange ② Lead

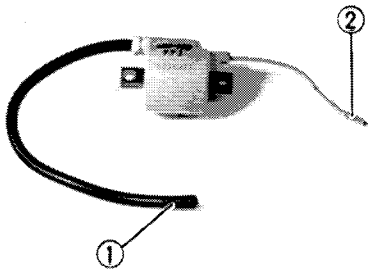

- Check the secondary coil for specified resistance.



Secondary Coil Resistance:
5.28 ~ 7.92kΩ at 20°C (68° F)

OUT OF SPECIFICATION

Ignition coil is faulty, replace it.

↓ BOTH MEET SPECIFICATION

8. Source coil resistance

- Disconnect the CDI magneto leads ① (Black/Red and Black).
- Connect the Pocket Tester (Ω x 100) to the source coil leads.

Tester (+) Lead → Black/Red ② Lead
Tester (-) Lead → Black ③ Lead

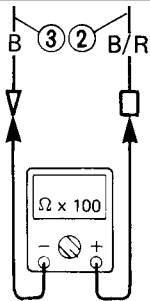
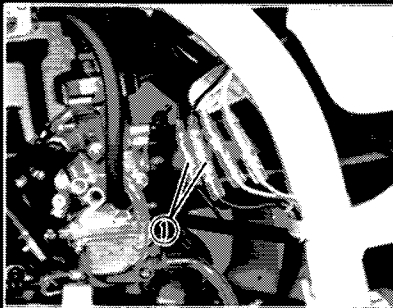

OUT OF SPECIFICATION

Source coil is faulty, replace it.

- Check the source coil for specified resistance.



Source Coil Resistance:
192 ~ 288Ω at 20°C (68° F)

↓ MEETS SPECIFICATION

7



9. Pickup coil resistance

- Disconnect the CDI magneto leads ① (White/Red and Black).
- Connect the Pocket Tester ($\Omega \times 10$) to the pickup coil leads.

Tester (+) Lead → White/Red ② Lead
 Tester (-) Lead → Black ③ Lead

- Check the pickup coil for specified resistance.

 **Pickup Coil Resistance:**
 16-24 Ω @ 20°C (68°F)

OUT OF SPECIFICATION

Pickup coil is faulty, replace it.

MEETS SPECIFICATION

10. Wiring connection (Entire ignition system)

- Check entire ignition system for connections. Refer to "WIRING DIAGRAM" section.

POOR CONNECTION

Correct.

CORRECT

CDI unit is faulty. Replace it.



Procedure (2)

Check;

1. Throttle cable free play
2. Throttle switch conduct
3. Carburetor switch conduct
4. Wiring connection
(Entire ignition control system)

1. Throttle cable free play

- Check the throttle cable free play. Refer to "THROTTLE CABLE FREE PLAY ADJUSTMENT" section in the CHAPTER 3.

Free Play:
4 ~ 6 mm (0.16 ~ 0.24 in)

OUT OF SPECIFICATION

Adjust the throttle cable free play.

MEETS TO SPECIFICATION

2. Throttle switch conduct

- Disconnect the throttle switch coupler ① (Yellow/Black and Black).
- Connect the Pocket Tester ($\Omega \times 1$) to the throttle switch coupler.

Tester (+) Lead → Yellow/Black ② Lead
Tester (-) Lead → Black ③ Lead

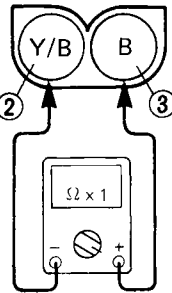
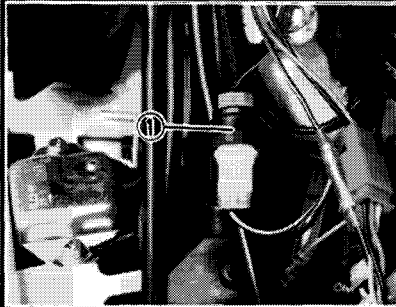

- Turn the throttle lever to open and close.
- Check the throttle switch for continuity.

BAD CONDITION

Throttle switch is faulty, replace it.

Throttle lever	Good condition	Bad condition		
Open	○	X	X	○
Close	X	○	X	○

○ : Continuity X : Nocontinuity

GOOD CONDITION

*

7



3. Carburetor switch conduct

- Disconnect the carburetor switch coupler ① (Yellow/Black and Black).
- Connect the Pocket Tester ($\Omega \times 1$) to the carburetor switch coupler.

Tester (+) Lead \rightarrow Yellow/Black ② Lead
 Tester (-) Lead \rightarrow Black ③ Lead

- Turn the throttle lever to open and close.
- Check the carburetor switch for continuity.

Throttle lever	Good condition	Bad condition		
Open	X	○	X	○
Close	○	X	X	○

○ : Continuity X : Nocontinuity

BAD CONDITION

Carburetor switch is faulty, replace it.



GOOD CONDITION

4. Wiring connection (Entire ignition control system)

- Check entire ignition control system for connections. Refer to "WIRING DIAGRAM" section.

POOR CONNECTION

Correct.



CORRECT

Control unit is faulty, replace it.

7



LIGHTING SYSTEM

CIRCUIT DIAGRAM

Below circuit diagram shows lighting system.

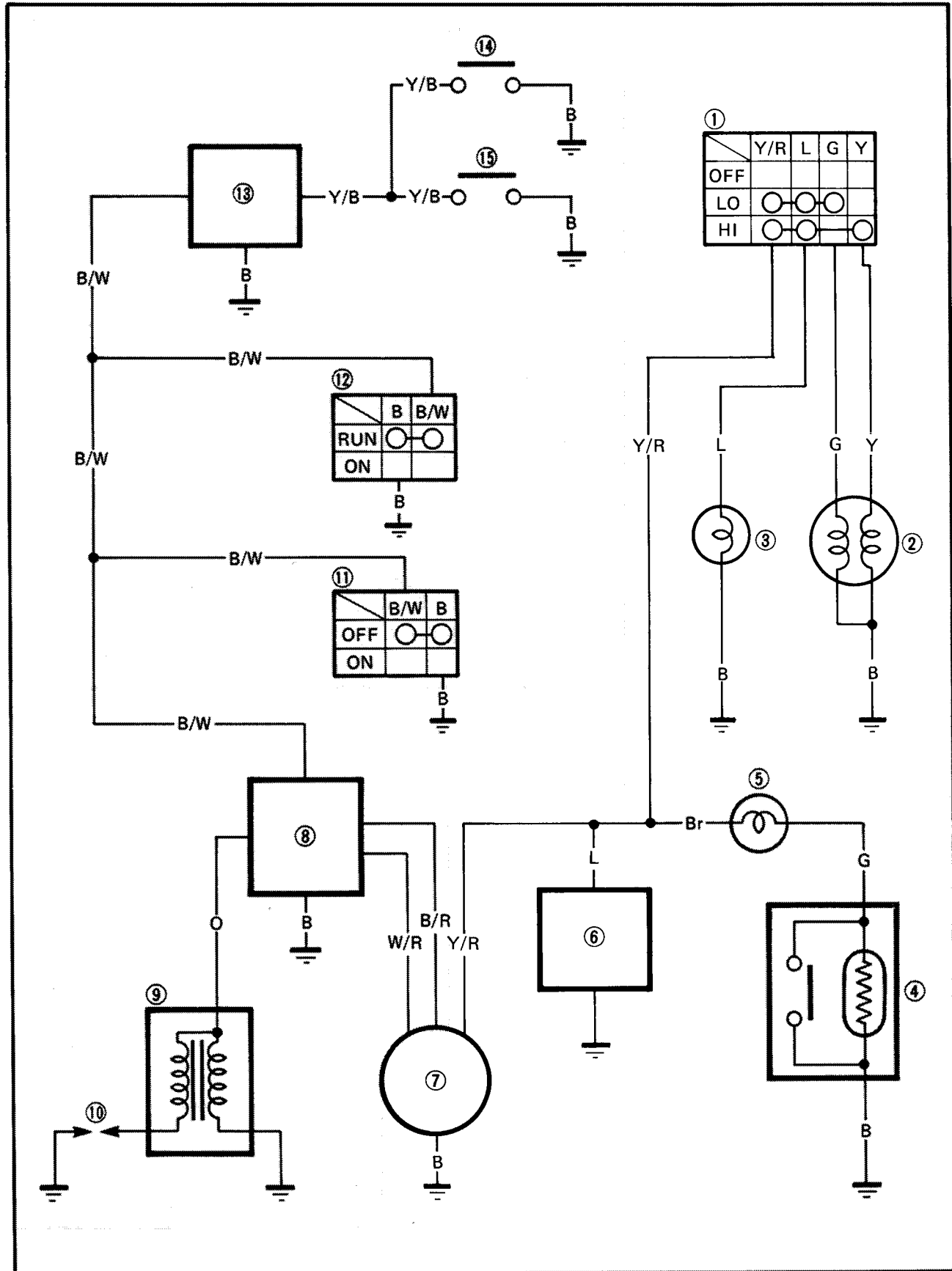

7

**NOTE:**

For the color codes, see page 7-2.

- ① "LIGHTS" (Dimmer) switch
- ② Headlight
- ③ Taillight
- ⑥ Voltage regulator
- ⑦ CDI magneto

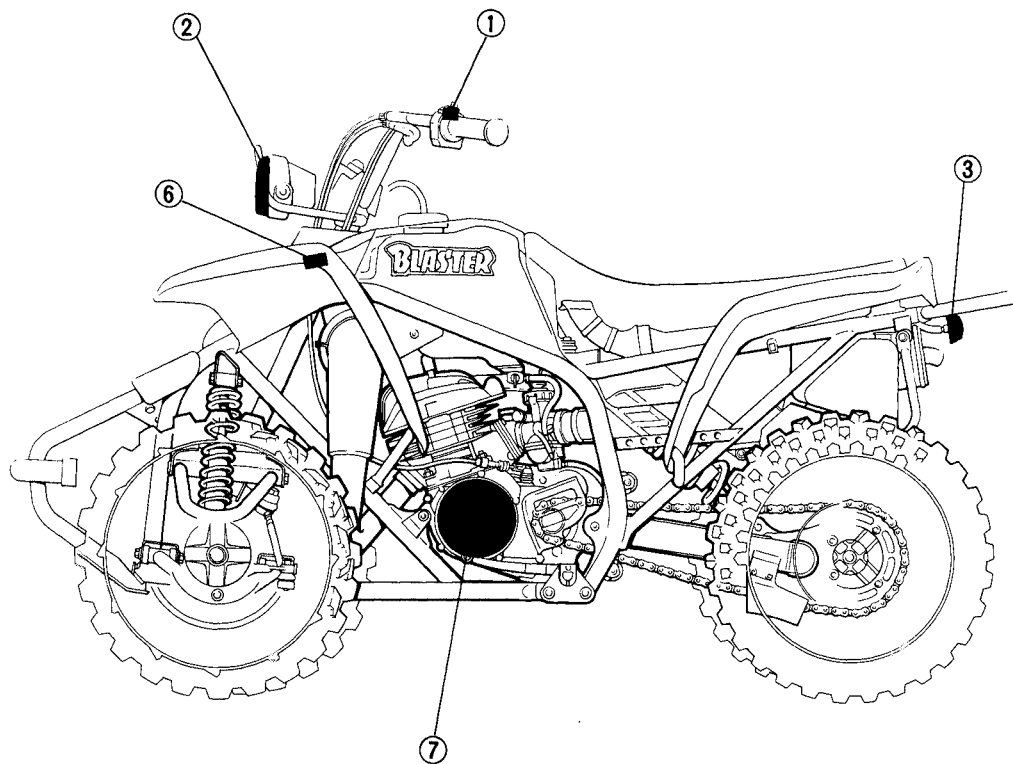



TROUBLESHOOTING

HEADLIGHT DOES NOT COME ON.

Procedure

Check;

- 1. Headlight bulb conduct
- 2. Headlight bulb socket conduct
- 3. "LIGHTS" (Dimmer) switch conduct
- 4. Lighting voltage
- 5. Lighting coil resistance
- 6. Wiring connection (Entire lighting system)

NOTE:

- Remove the following parts before troubleshooting.
 - 1) Headlight cover
 - 2) Fuel tank cover (Front)
- Use the following special tools in the troubleshooting.



Pocket Tester:
P/N. YU-03112
P/N. 90890-03112



Inductive Tachometer:
P/N. YU-03113
P/N. 90890-03113

1. Headlight bulb conduct

- Remove the headlight bulb. Refer to "CHAPTER 3. HEADLIGHT BULB REPLACEMENT" section.

⚠ WARNING:

Keep flammable products or your hands away from bulb while it is on, it will be hot. Do not touch bulb until it cools down.

- Connect the Pocket Tester ($\Omega \times 1$) to the bulb terminals.

Tester (+) Lead → Terminal ①
Tester (-) Lead → Terminal ②

Tester (+) Lead → Terminal ①
Tester (-) Lead → Terminal ③

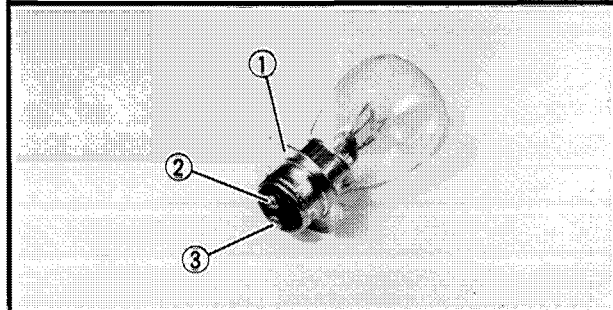

- Check the bulb for continuity.

CONTINUITY DOES NOT EXIST ON ONE CIRCUIT.



Bulb is faulty, replace it.

CONTINUITY EXISTS ON BOTH CIRCUITS.

7



2. Headlight bulb socket conduct

- Install the bulb to the headlight socket.
- Connect the Pocket Tester ($\Omega \times 1$) to the headlight coupler (Black, Yellow and Green).

Tester (+) Lead → Yellow ② Lead
Tester (-) Lead → Black ① Lead

Tester (+) Lead → Green ③ Lead
Tester (-) Lead → Black ① Lead

- Check the bulb socket for continuity.

CONTINUITY DOES NOT EXIST ON ONE CIRCUIT.



Bulb socket is faulty, replace it.

CONTINUITY EXISTS ON BOTH CIRCUITS.

3. "LIGHTS" (Dimmer) switch conduct.

- Disconnect the "LIGHTS" (Dimmer) switch coupler ① (Yellow/Red, Blue and Black) and headlight leads ② (Yellow and Green).
- Connect the Pocket Tester ($\Omega \times 1$) to the coupler and leads as shown.

A

Tester (+) Lead → Yellow/Red ⑤ Lead
Tester (-) Lead → Yellow ③ Lead

B

Tester (+) Lead → Yellow/Red ⑤ Lead
Tester (-) Lead → Green ④ Lead



- Turn the "LIGHTS" (Dimmer) switch to "OFF", "LO" and "HI".
- Check the "LIGHTS" (Dimmer) switch for continuity.

A				
Switch position	Good condition	Bad condition		
OFF	X	○	X	○
HI	○	X	X	○

B				
Switch position	Good condition	Bad condition		
OFF	X	○	X	○
LO	○	X	X	○

○ : Continuity X : Nocontinuity

BAD CONDITION

"LIGHTS" (Dimmer) switch is faulty, replace it.

GOOD CONDITION

4. Lighting voltage

- Connect the Pocket Tester (AC20V) to the wireharness. (Yellow and Black) as shown.

Tester (+) Lead → Yellow ② Lead
 Tester (-) Lead → Black ① Lead

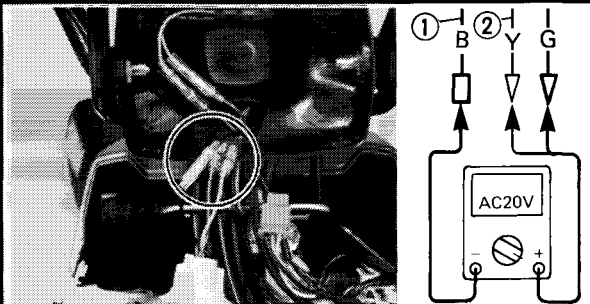

- Turn the "LIGHTS" (Dimmer) switch to the "HI" position.
- Connect the Inductive Tachometer to the spark plug lead.
- Start the engine and accelerate to about 5,000 r/min.

CAUTION:
 Do not run the engine in neutral above 6,000 r/min for more than 1 or 2 seconds.

- Check the lighting voltage for specification.

MEETS SPECIFICATION

Lighting system is good condition.



Lighting Voltage:
 13.5 ~ 14.1V at 5,000 r/min

OUT OF SPECIFICATION

7



5. Lighting coil resistance

- Disconnect the CDI magneto leads ① (Yellow/Red and Black).
- Connect the Pocket Tester ($\Omega \times 1$) to the lighting coil leads.

Tester (+) Lead → Yellow/Red ② Lead
 Tester (-) Lead → Black ③ Lead

- Check the lighting coil for specified resistance.

 **Lighting Coil Resistance:**
 0.16 ~ 0.24 Ω at 20°C (68°F)

OUT OF SPECIFICATION

Lighting coil is faulty, replace it.

MEETS SPECIFICATION

6. Wiring connection (Entire lighting system)

- Check entire lighting system for connections. Refer to "WIRING DIAGRAM" section.

CORRECT

Voltage regulator is faulty, replace it.



TAILLIGHT DOES NOT COME ON.

Procedure

Check;

- | | |
|-------------------------------------|---|
| 1. Taillight bulb conduct | 4. Lighting voltage |
| 2. Taillight bulb socket conduct | 5. Lighting coil resistance |
| 3. "LIGHTS" (Dimmer) switch conduct | 6. Wiring connection (Entire lighting system) |

NOTE:

- Remove the following parts before troubleshooting.
 - 1) Fuel tank cover (Front)
- Use the following special tools in the troubleshooting.



Pocket Tester:
P/N. YU-03112
P/N. 90890-03112



Inductive Tachometer:
P/N. YU-03113
P/N. 90890-03113

1. Taillight bulb conduct

- Remove the taillight lens and bulb.
- Connect the Pocket Tester ($\Omega \times 1$) to the bulb terminals.

Tester (+) Lead → Terminal ①
Tester (-) Lead → Terminal ②

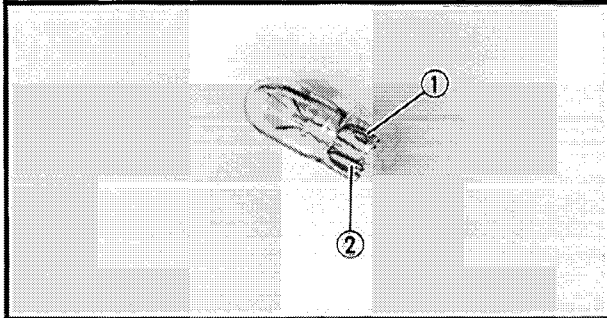

- Check the bulb for continuity.

NOCONTINUITY

Bulb is faulty, replace it.

CONTINUITY

2. Taillight bulb socket conduct

- Install the bulb to the taillight socket.
- Disconnect the taillight leads (Blue and Black).
- Connect the Pocket Tester ($\Omega \times 1$) to the taillight leads (Blue and Black).

7



Tester (+) Lead → Blue ① Lead
 Tester (-) Lead → Black ② Lead

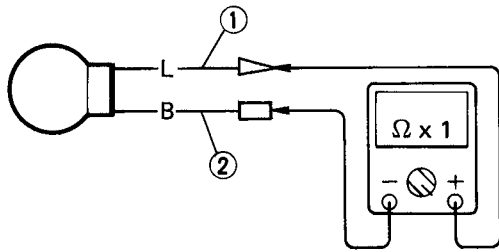

• Check the bulb socket for continuity.

NOCONTINUITY

Bulb socket is faulty, replace it.

CONTINUITY

3. "LIGHTS" (Dimmer) switch conduct

- Disconnect the "LIGHTS" (Dimmer) switch coupler ① (Yellow/Red, Blue and Black).
- Connect the Pocket Tester ($\Omega \times 1$) to the coupler as shown.

Tester (+) Lead → Blue ② Lead
 Tester (-) Lead → Yellow/Red ③ Lead

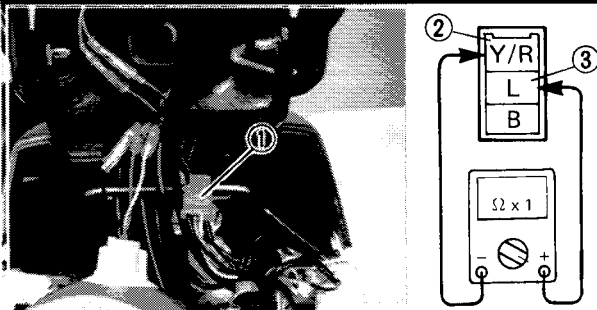

- Turn the "LIGHTS" (Dimmer) switch to "OFF", "LO" and "HI".
- Check the "LIGHTS" (Dimmer) switch for continuity.

BAD CONDITION

"LIGHTS" (Dimmer) switch is faulty, replace it.

Switch position	Good condition		Bad condition	
	○	X	○	X
OFF	X	○	X	○
HI or LO	○	X	X	○

○: Continuity X: Nocontinuity

GOOD CONDITION

7



4. Lighting voltage

- Connect the Pocket Tester (AC20V) to the wireharness ① (Blue and Black) as shown.

Tester (+) Lead → Blue ② Lead
 Tester (-) Lead → Black ③ Lead

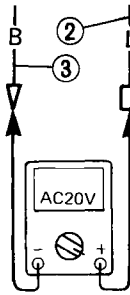
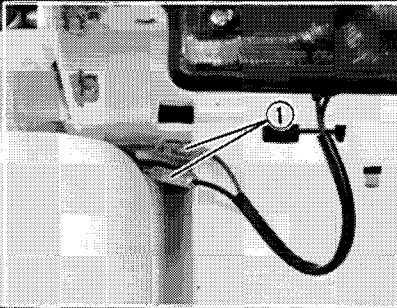

- Turn the "LIGHTS" (Dimmer) switch to "LO" or "HI" position.
- Connect the Inductive Tachometer to the spark plug lead.
- Start the engine and accelerate to about 5,000 r/min.

CAUTION:

Do not run the engine in neutral above 6,000 r/min for more than for 2 seconds.

- Check the lighting voltage for specification.

MEETS SPECIFICATION



Lighting Voltage:
 13.5 ~ 14.1V at 5,000 r/min

Lighting system is good condition.



OUT OF SPECIFICATION

7



5. Lighting coil resistance

- Disconnect the CDI magneto leads ① (Yellow/Red and Black).
- Connect the Pocket Tester ($\Omega \times 1$) to the lighting coil leads.

Tester (+) Lead → Yellow/Red ② Lead
 Tester (-) Lead → Black ③ Lead

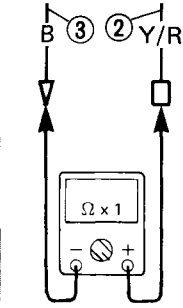
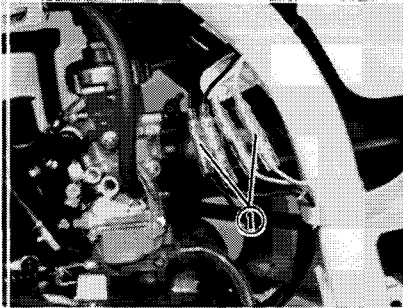

- Check the lighting coil for specified resistance.



Lighting Coil Resistance:
 0.16 ~ 0.24 Ω at 20°C (68°F)

OUT OF SPECIFICATION

Lighting coil is faulty, replace it.

MEETS SPECIFICATION

6. Wiring connection (Entire lighting system)

- Check entire lighting system for connections. Refer to "WIRING DIAGRAM" section.

CORRECT

Voltage regulator is faulty, replace it.



SIGNAL SYSTEM

CIRCUIT DIAGRAM

Below circuit diagram shows signal system.

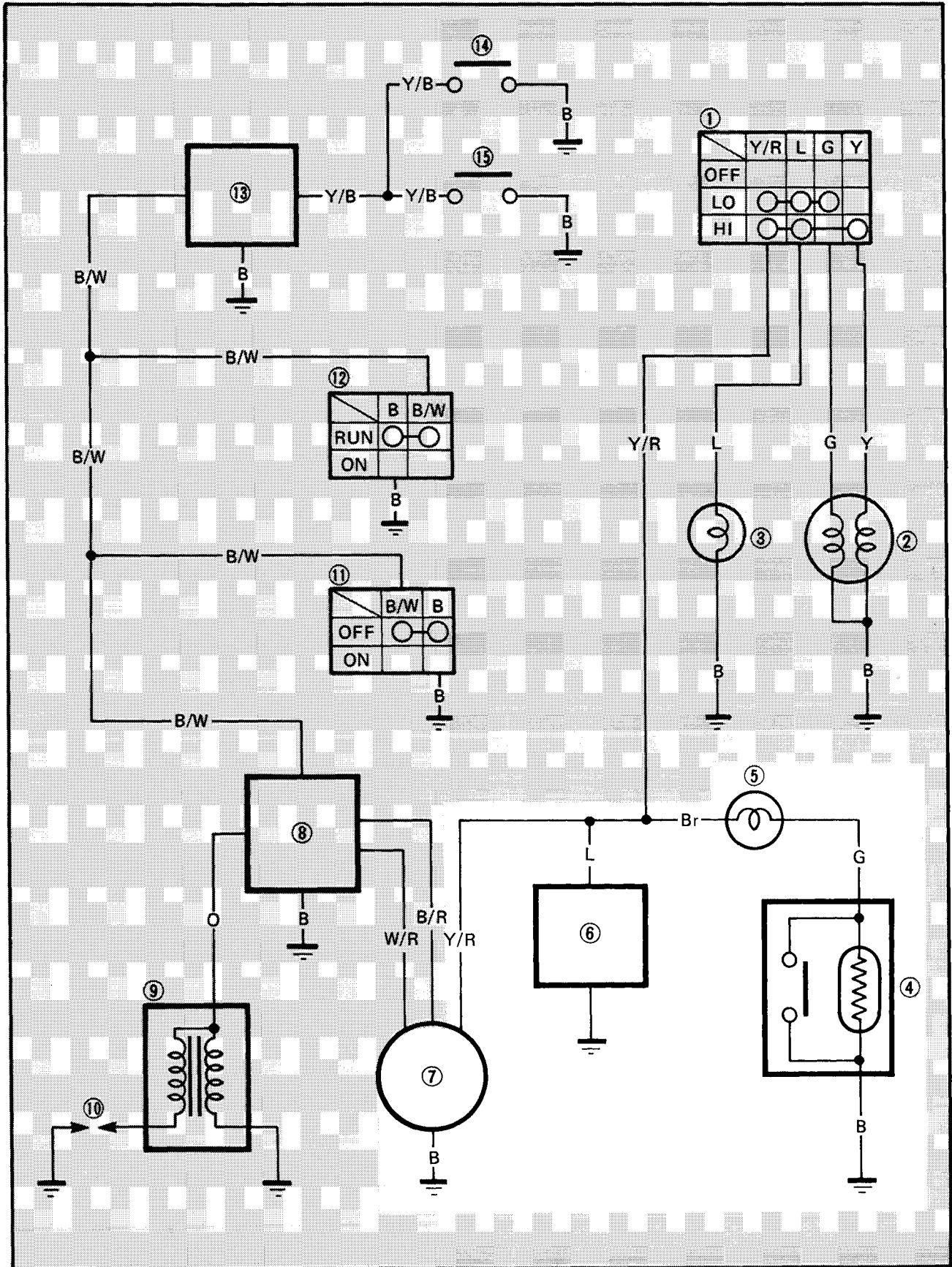

7

**NOTE:**

For the color codes, see page 7-2.

- ④ Oil level gauge
- ⑤ "OIL" indicator light
- ⑥ Voltage regulator
- ⑦ CDI magneto

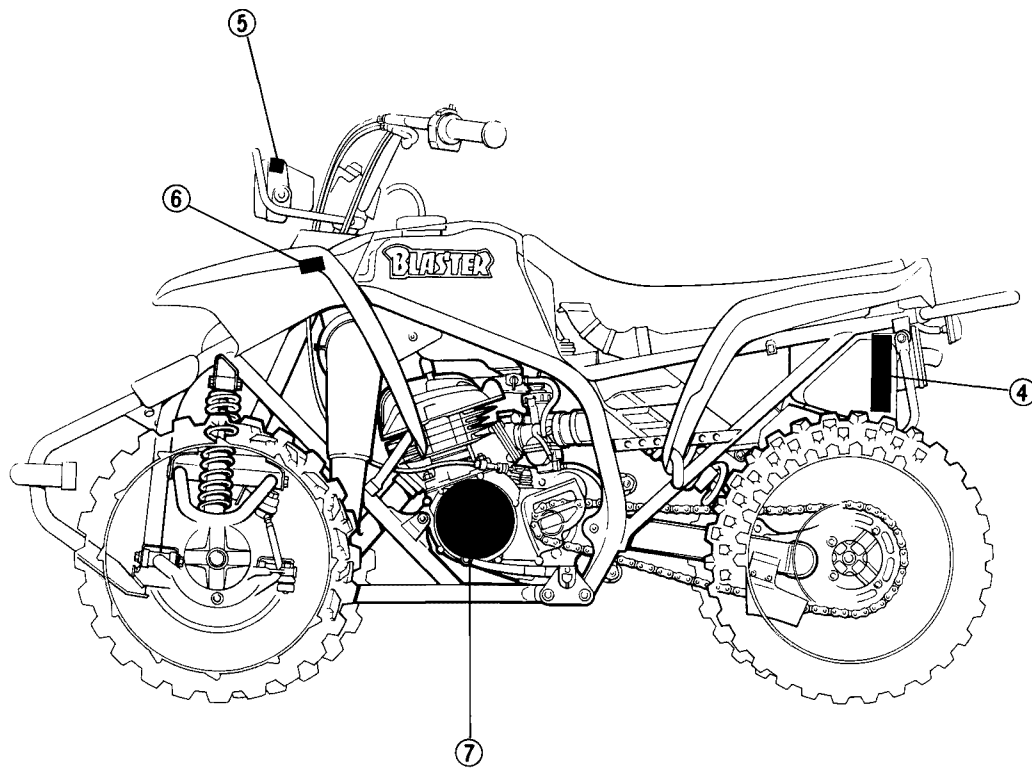
**7**



TROUBLESHOOTING

"OIL" INDICATOR LIGHT DOES NOT COME ON.

Procedure

Check;

- | | |
|--|---|
| 1. "OIL" indicator light bulb conduct | 4. Oil level gauge |
| 2. "OIL" indicator light bulb socket conduct | 5. Wiring connection (Entire signal system) |
| 3. Lighting voltage | |

NOTE:

- Fill the engine oil to oil tank before troubleshooting.
- Remove the following parts before troubleshooting.
 - 1) Headlight cover
- Use the following special tools in this troubleshooting.



Pocket Tester:
P/N. YU-03112
P/N. 90890-03112



Inductive Tachometer:
P/N. YU-03113
P/N. 90890-03113

1. "OIL" indicator light bulb conduct

- Remove the "OIL" indicator light bulb.
- Connect the Pocket Tester ($\Omega \times 1$) to the bulb terminals.

Tester (+) Lead \rightarrow Terminal ①
Tester (-) Lead \rightarrow Terminal ②

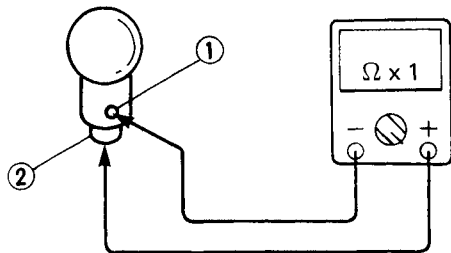

- Check the "OIL" indicator light bulb for continuity.

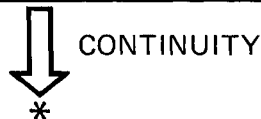

NOCONTINUITY

"OIL" indicator light bulb is faulty, replace it.

7



2. "OIL" indicator light bulb socket conduct

- Install the bulb to the "OIL" indicator light socket.
- Disconnect the "OIL" indicator light leads ① (Brown and Green).
- Connect the Pocket Tester ($\Omega \times 1$) to the "OIL" indicator light leads.

Tester (+) Lead → Brown ② Lead
 Tester (-) Lead → Green ③ Lead

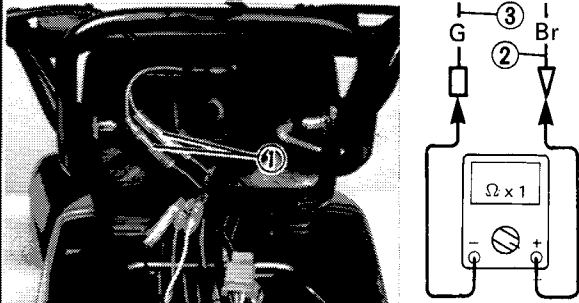

- Check the bulb socket for continuity.

NOCONTINUITY

"OIL" indicator light bulb socket is faulty, replace it.



3. Lighting voltage

- Connect the Pocket Tester (AC20V) to wireharness ①.

Tester (+) Lead → Brown ② Lead
 Tester (-) Lead → Ground

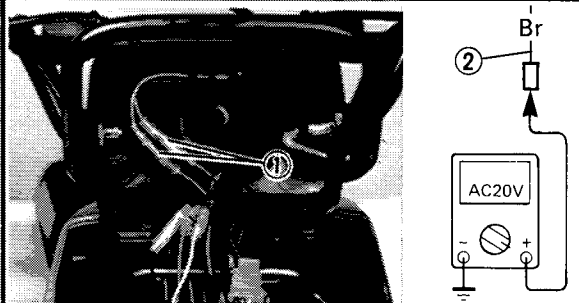

- Connect the Inductive Tachometer to the spark plug lead.
- Start the engine and accelerate to about 5,000 r/min.

7



CAUTION:

Do not run the engine in neutral above 6,000 r/min for more than 1 or 2 seconds.

- Check the lighting voltage for specification.



Lighting Voltage:
13.5 ~ 14.1V at 5,000 r/min

OUT OF SPECIFICATION

MEETS SPECIFICATION

Lighting system is faulty, check the lighting coil resistance and the wiring connection (Entire lighting system). Refer to the "LIGHTING SYSTEM" section.

4. Oil level gauge

- Disconnect the oil level gauge leads ① (Green and Black).
- Connect the jumper lead ② to the oil level gauge leads.

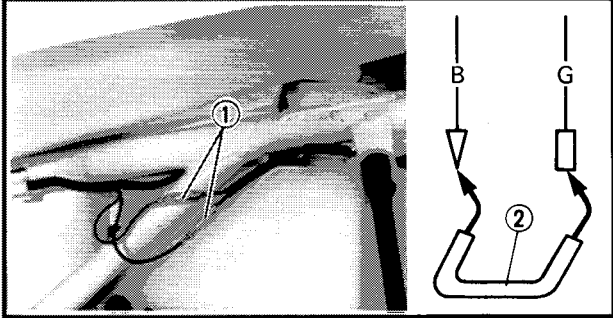

"OIL" INDICATOR LIGHT COMES ON.

- Start the engine.

Oil level gauge is faulty, replace it.

"OIL" INDICATOR LIGHT DOES NOT COME ON.

5. Wiring connection (Entire signal system)

- Check entire signal system for connections. Refer to "WIRING DIAGRAM" section.

TROUBLESHOOTING

NOTE:

The following troubleshooting does not cover all the possible causes of trouble. It should be helpful, however, as a guide to troubleshooting. Refer to the relative procedure in this manual for inspection, adjustment and replacement of parts.

STARTING FAILURE/HARD STARTING

FUEL SYSTEM

PROBABLE CAUSE

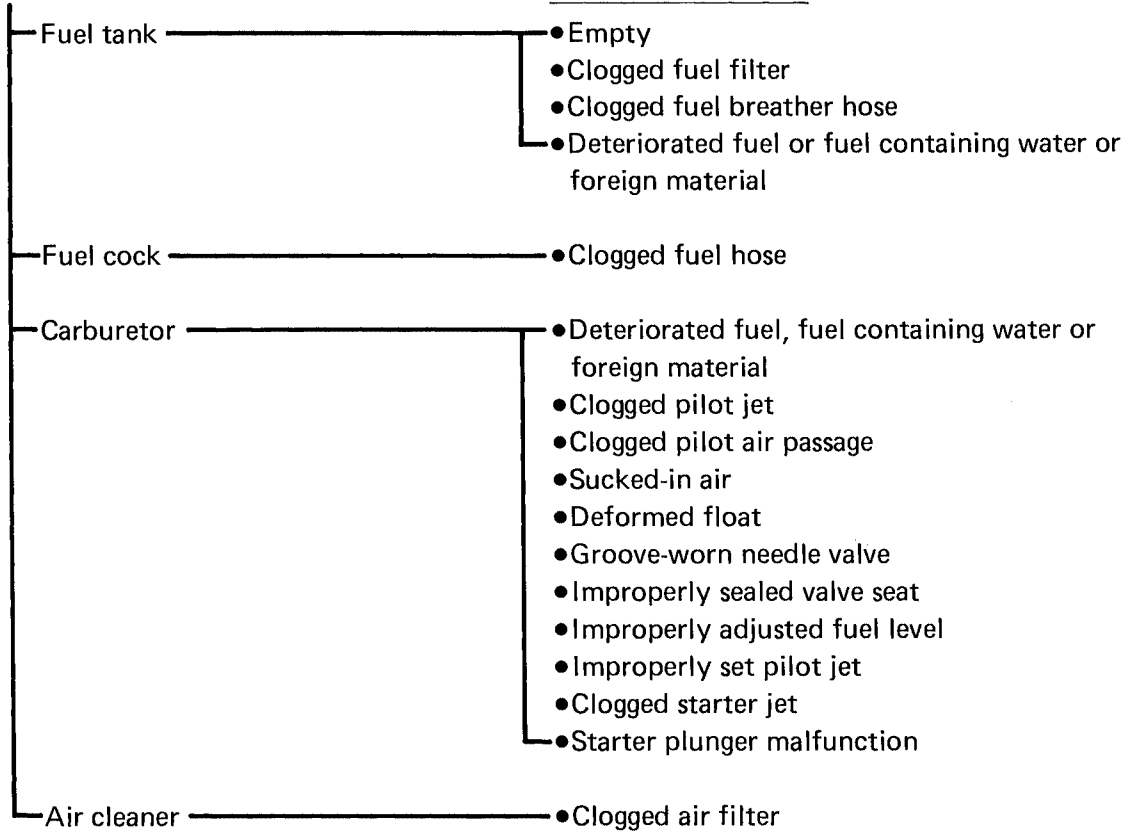

ELECTRICAL SYSTEM

PROBABLE CAUSE

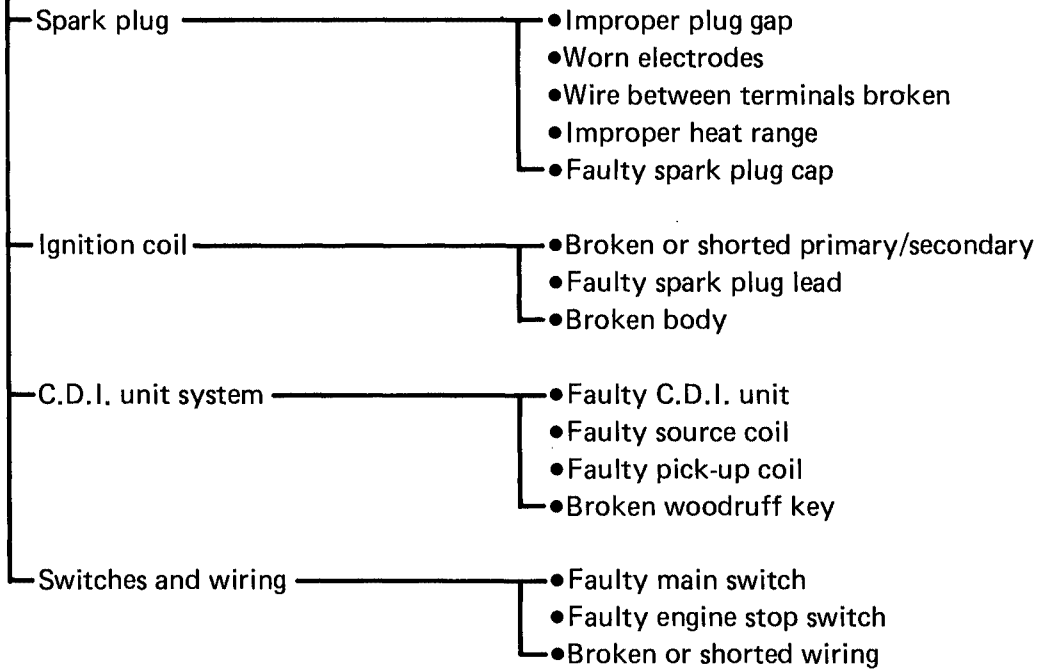

COMPRESSION SYSTEM

PROBABLE CAUSE

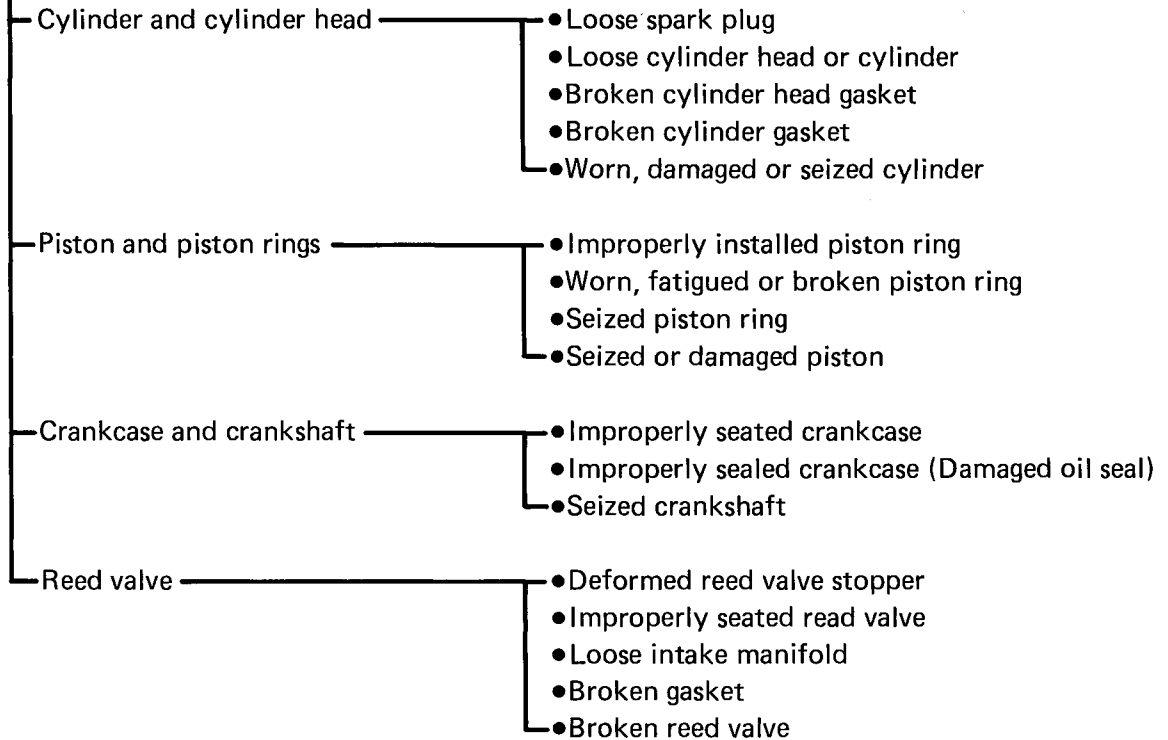

POOR IDLE SPEED PERFORMANCE

POOR IDLE SPEED PERFORMANCE

PROBABLE CAUSE

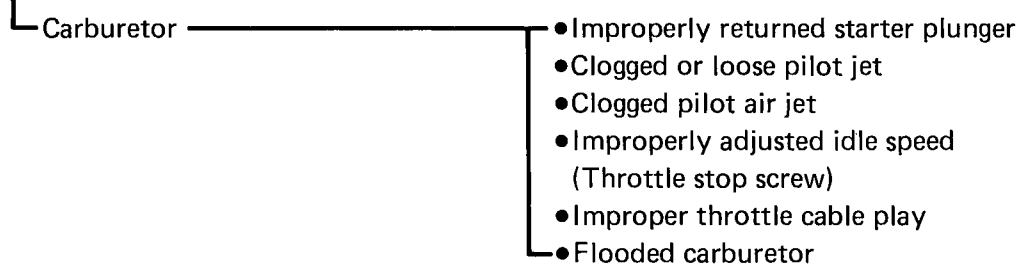

POOR MEDIUM AND HIGH SPEED PERFORMANCE

FUEL SYSTEM

PROBABLE CAUSE

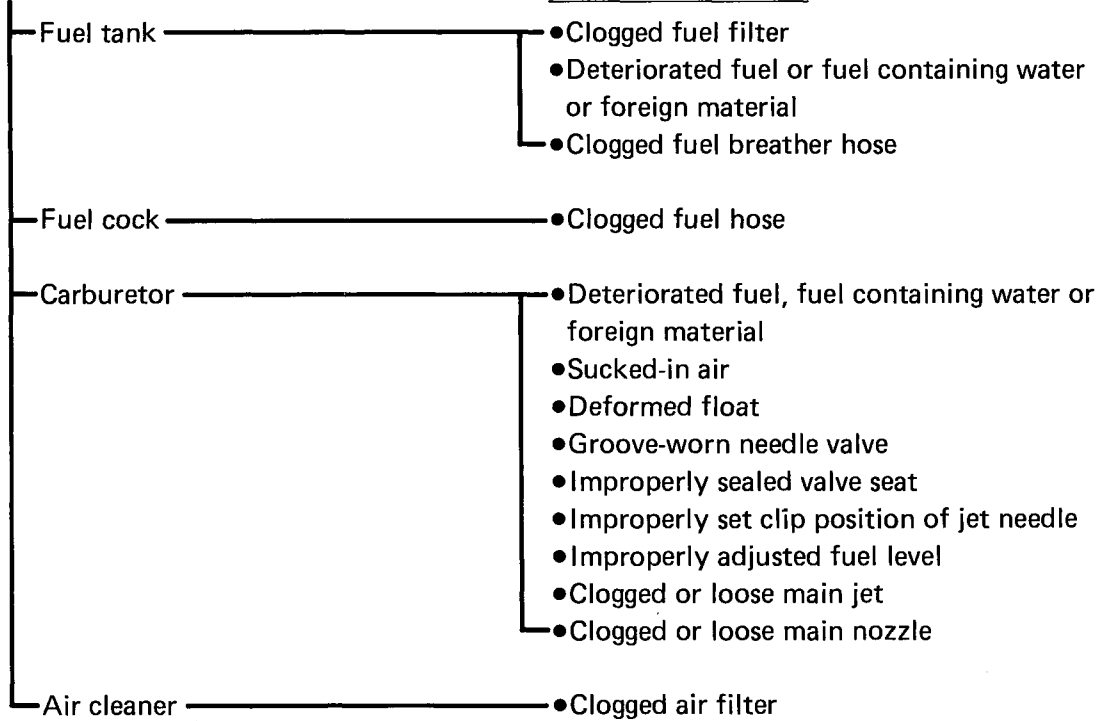

ELECTRICAL SYSTEM

PROBABLE CAUSE

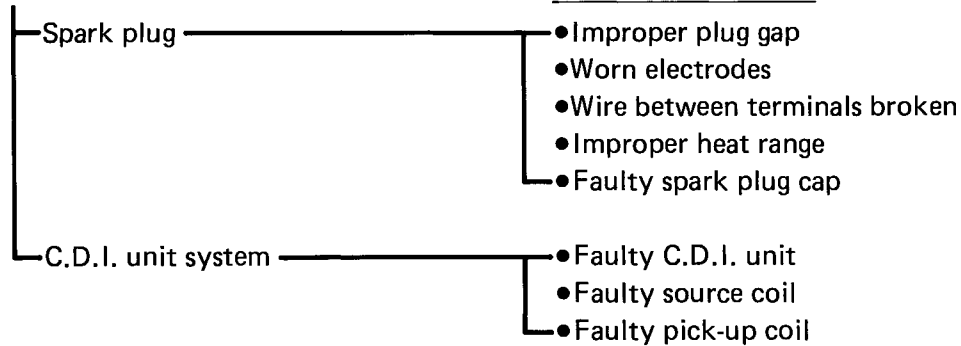

COMPRESSION SYSTEM

PROBABLE CAUSE

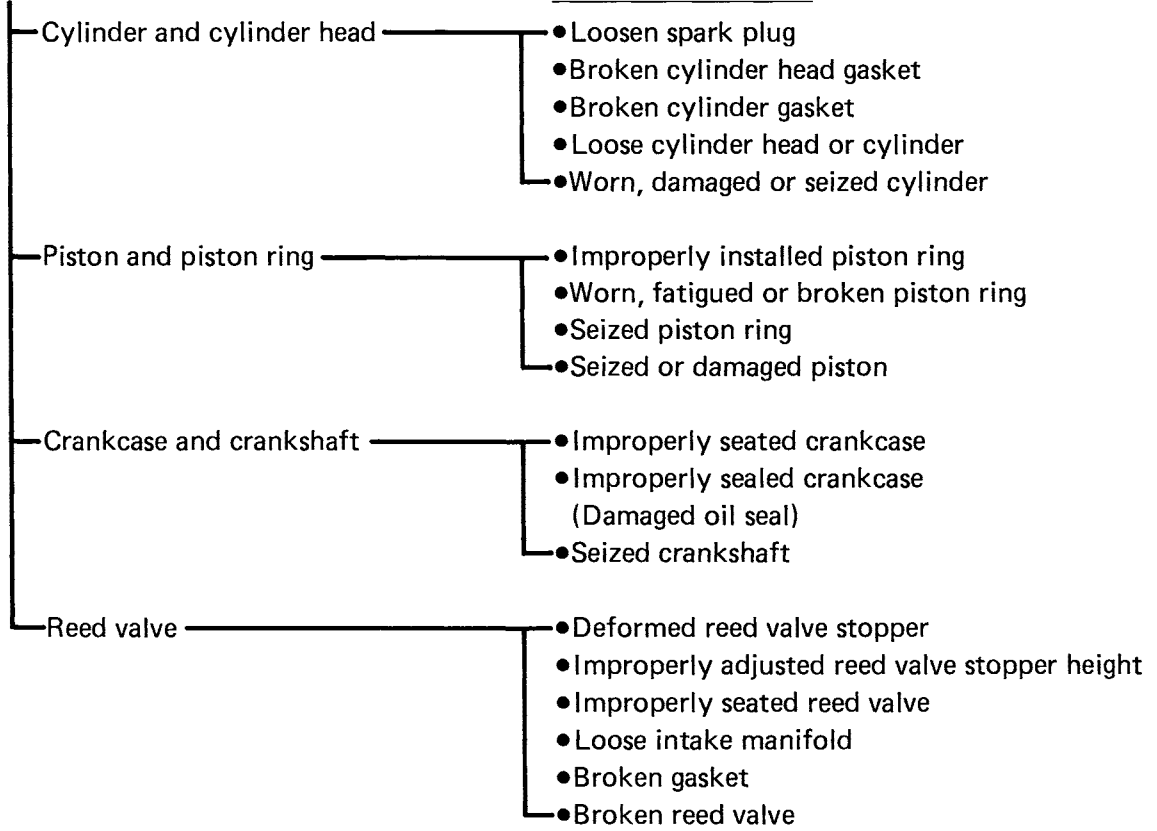

FAULTY GEAR SHIFTING

HARD SHIFTING

PROBABLE CAUSE

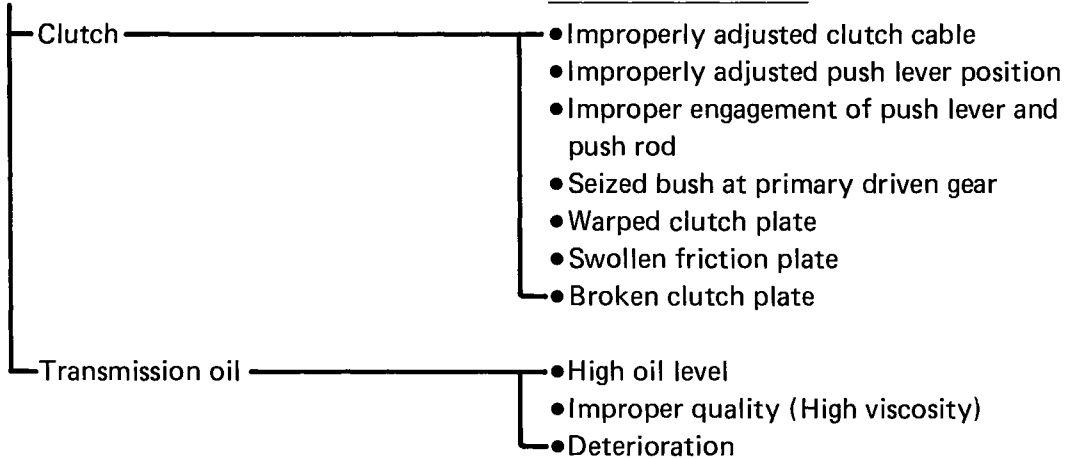

CHANGE PEDAL DOES NOT MOVE

PROBABLE CAUSE

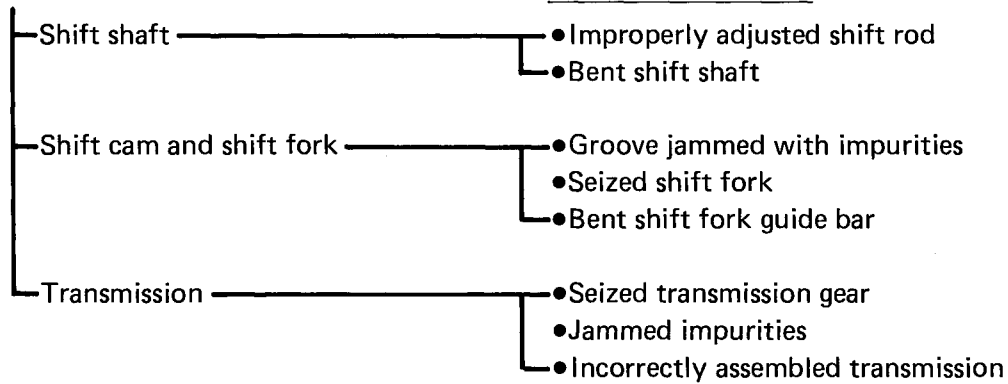

JUMP-OUT GEAR

PROBABLE CAUSE

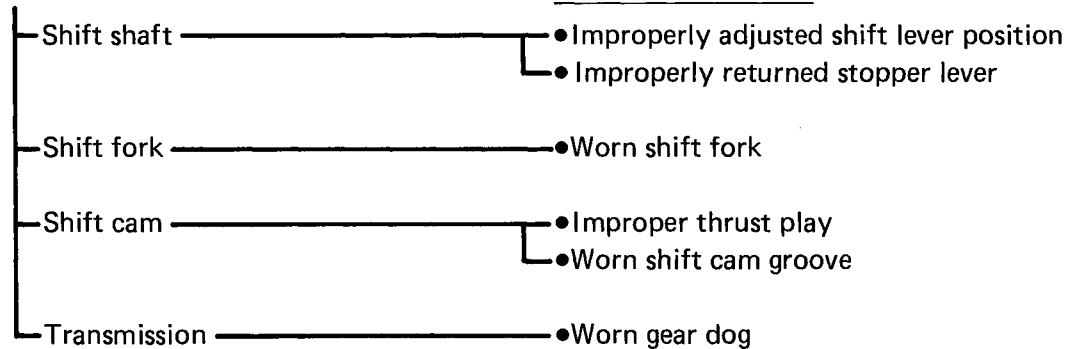

CLUTCH SLIPPING/DRAGGING

CLUTCH SLIPPING

PROBABLE CAUSE

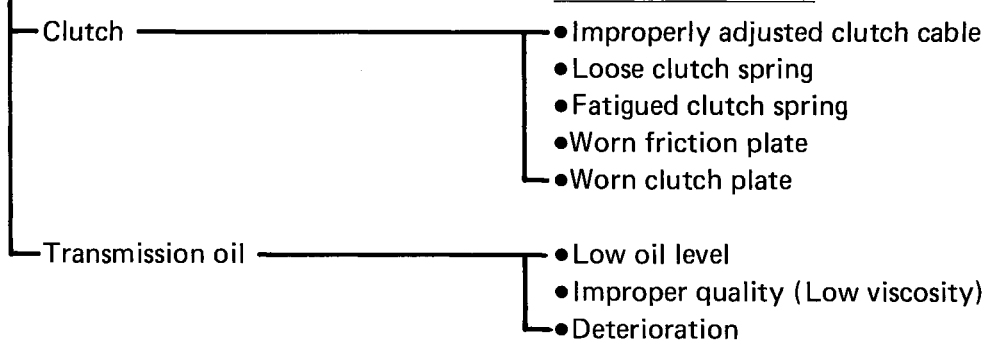

CLUTCH DRAGGING

PROBABLE CAUSE

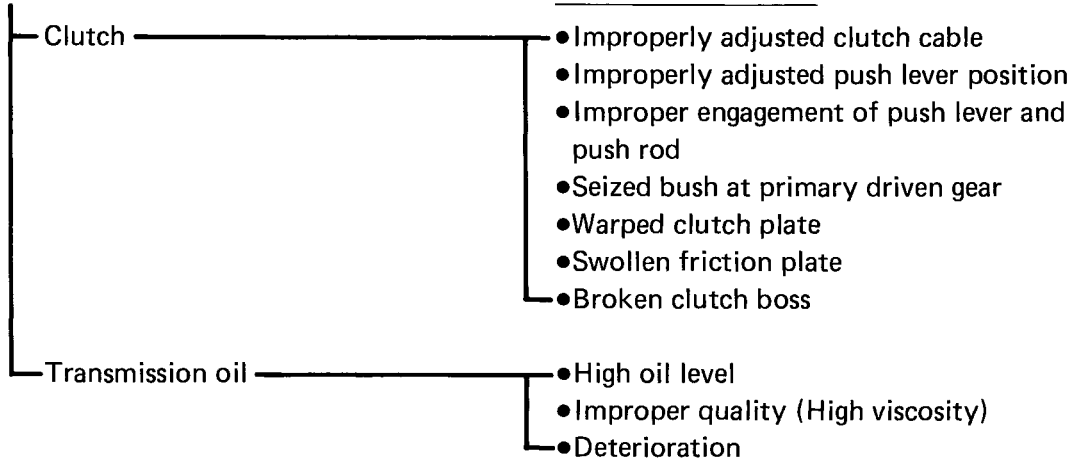

IMPROPER KICKING

SLIPPING

PROBABLE CAUSE

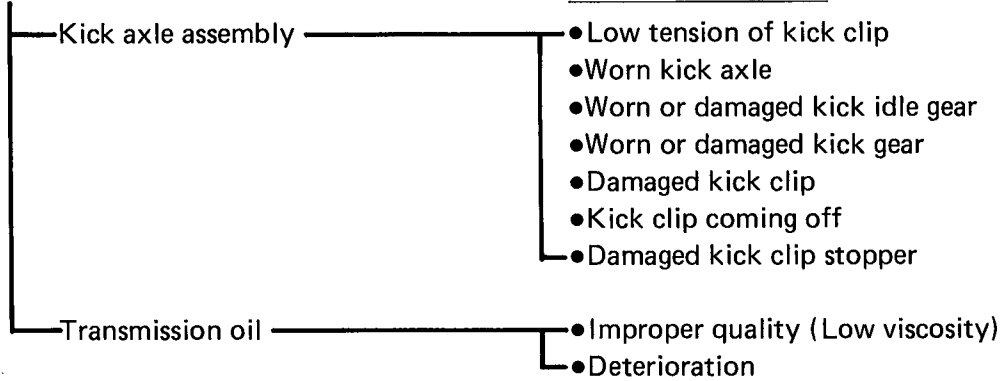

HARD KICKING

PROBABLE CAUSE

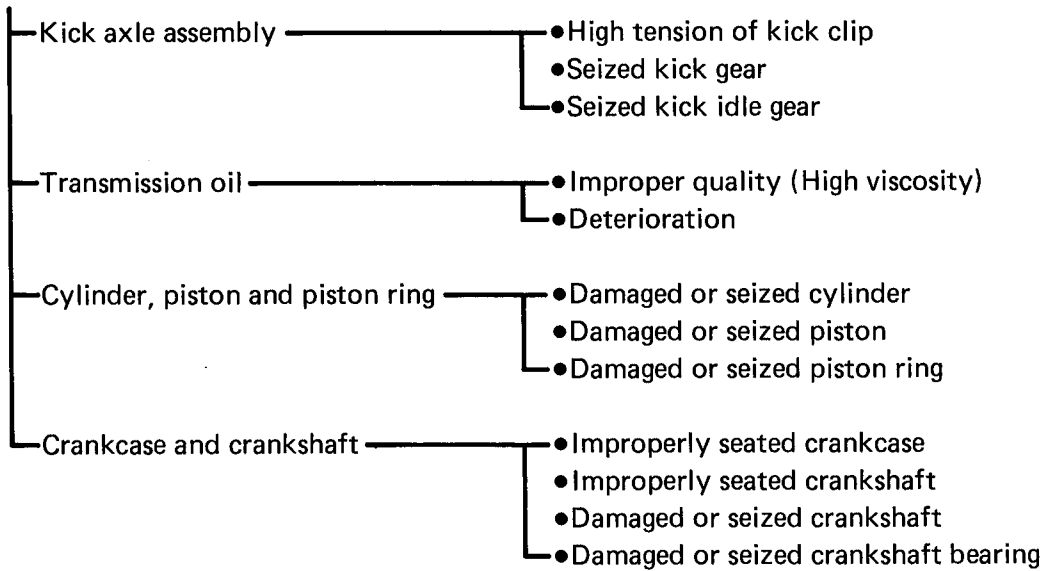

KICK CRANK NOT RETURNING

PROBABLE CAUSE

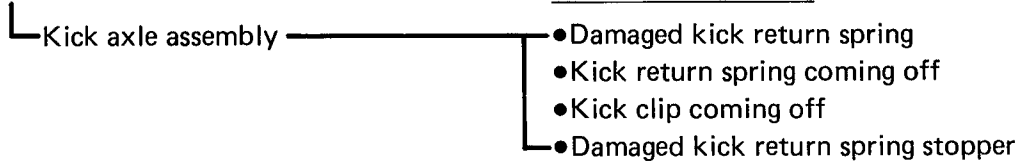

FAULTY BRAKE

POOR BRAKING EFFECT (FRONT)

└ Drum brake

PROBABLE CAUSE

- Worn brake shoe
- Worn or rusty brake drum
- Improperly adjusted brake free play
- Improper brake cam lever position
- Improper brake shoe position
- Fatigue/Damaged return spring
- Oily or greasy brake shoe
- Oily or greasy brake drum
- Broken brake cable

POOR BRAKING EFFECT (REAR)

└ Disc brake

PROBABLE CAUSE

- Worn brake pad
- Worn brake disc
- Fatigue/Damage ratchet spring
- Damage ratchet
- Oily or greasy brake disc
- Oily or greasy brake pad
- Broken brake cable

SHOCK ABSORBER MALFUNCTION

MALFUNCTION

PROBABLE CAUSE

- Bent or damaged damper rod
- Damaged oil seal lip
- Fatigued shock absorber spring

INSTABLE HANDLING

INSTABLE HANDLING

PROBABLE CAUSE

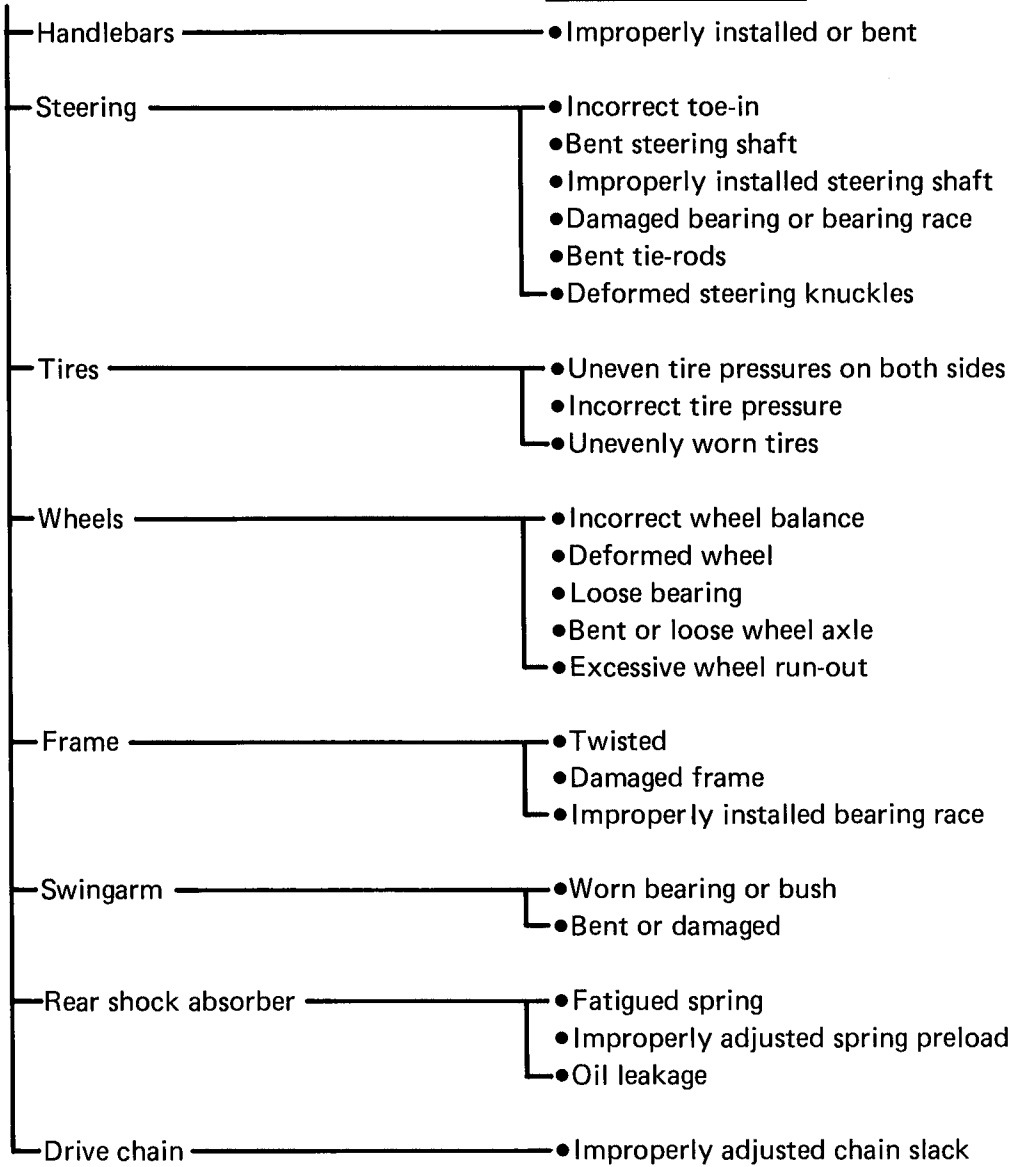

FAULTY LIGHTING SYSTEM

HEADLIGHT DARK

PROBABLE CAUSE

- Improper bulb
- Too many electric accessories
- Hard charging (Broken charging coil and/or faulty rectifier/regulator)
- Incorrect connection
- Improperly grounded
- Poor contacts (main or light switch)
- Bulb life expired

BULB BURNT OUT

PROBABLE CAUSE

- Improper bulb
- Faulty rectifier/regulator
- Improperly grounded
- Faulty main and/or light switch
- Bulb life expired

OVERHEATING

OVERHEATING

PROBABLE CAUSE

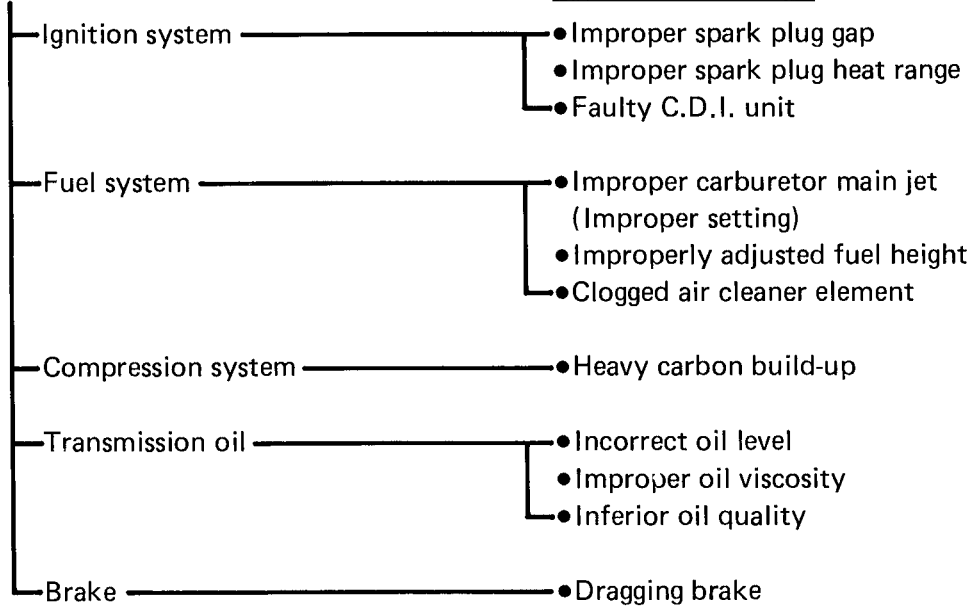

FOREWORD

This Supplementary Service Manual has been prepared to introduce new service and new data for the YFS200A. For complete information on service procedures, it is necessary to use this Supplementary Service Manual together with following manual:

YFS200U Service Manual: LIT-11616-06-41

**YFS200A
SUPPLEMENTARY SERVICE MANUAL
© 1989 by Yamaha Motor Corporation U.S.A.
1st Edition, July 1989
All rights reserved. Any reprinting or
unauthorized use without the written
permission of Yamaha Motor Corporation
U.S.A. is expressly prohibited.
Printed in U.S.A.
P/N LIT-11616-07-20**

NOTICE

This manual was written by the Yamaha Motor Company primarily for use by Yamaha dealers and their qualified mechanics. It is not possible to put an entire mechanic's education into one manual, so it is assumed that persons using this book to perform maintenance and repairs on Yamaha machines have a basic understanding of the mechanical concepts and procedures inherent in machine repair technology. Without such knowledge, attempted repairs or service to this model may render it unfit to use and/or unsafe.

Yamaha Motor Company, Ltd. is continually striving to improve all models manufactured by Yamaha. Modifications and significant changes in specifications or procedures will be forwarded to all Authorized Yamaha dealers and will, where applicable, appear in future editions of this manual.

TECHNICAL PUBLICATIONS
SERVICE DIVISION
MOTORCYCLE GROUP
YAMAHA MOTOR CO., LTD.

HOW TO USE THIS MANUAL

PARTICULARLY IMPORTANT INFORMATION

This material is distinguished by the following notation.



The Safety Alert Symbol means ATTENTION! BECOME ALERT! YOUR SAFETY IS INVOLVED!



Failure to follow WARNING instructions could result in severe injury or death to the machine operator, a bystander, or a person inspecting or repairing the machine.



A CAUTION indicates special precautions that must be taken to avoid damage to the machine.

NOTE:

A NOTE provides key information to make procedures easier or clearer.

MANUAL FORMAT

























All of the procedures in this manual are organized in a sequential, step-by-step format. The information has been compiled to provide the mechanic with an easy to read, handy reference that contains comprehensive explanations of all disassembly, repair, assembly, and inspection operations.

In this revised format, the condition of a faulty component will precede an arrow symbol and the course of action required will follow the symbol, e.g.,

- Bearings
Pitting/Damage → Replace.

EXPLODED DIAGRAM

Each chapter provides exploded diagrams before each disassembly section for ease in identifying correct disassembly and assembly procedures.

① GEN INFO 	② SPEC 	
③ INSP ADJ 	④ ENG 	
⑤ COOL 	⑥ CARB 	
⑦ DRIV 	⑧ CHAS 	
⑨ ELEC 	⑩ TRBL SHTG ? 	
⑪ 	⑫ 	
⑬ 	⑭ 	
⑮ 	⑯ 	
⑰ 	⑱ 	
⑲ 	⑳ 	㉑ 
㉒ 	㉓ 	㉔ 

ILLUSTRATED SYMBOLS

(Refer to the illustration)

Illustrated symbols ① to ⑩ are designed as thumb tabs to indicate the chapter's number and content.

- ① General information
- ② Specifications
- ③ Periodic inspection and adjustment
- ④ Engine
- ⑤ Cooling system
- ⑥ Carburetion
- ⑦ Drive train
- ⑧ Chassis
- ⑨ Electrical
- ⑩ Troubleshooting

Illustrated symbols ⑪ to ⑰ are used to identify the specifications appearing in the text.

- ⑪ Filling fluid
- ⑫ Lubricant
- ⑬ Special tool
- ⑭ Tightening
- ⑮ Wear limit, clearance
- ⑯ Engine speed
- ⑰ Ω , V, A ...

Illustrated symbols ⑱ to ㉔ in the exploded diagram indicate grade of lubricant and location of lubrication point.

- ⑱ Apply locking agent (LOCTITE®)
- ⑲ Apply engine oil
- ⑳ Apply gear oil
- ㉑ Apply molybdenum disulfide oil
- ㉒ Apply wheel bearing grease
- ㉓ Apply lightweight lithium-soap base grease
- ㉔ Apply molybdenum disulfide grease

CONTENTS

GENERAL INFORMATION	1
MACHINE IDENTIFICATION	1
VEHICLE IDENTIFICATION NUMBER (FOR USA, AUS AND CDN)	1
FRAME SERIAL NUMBER (EXCEPT FOR USA, AUS AND CDN)	1
ENGINE SERIAL NUMBER	1
SPECIFICATION	2
GENERAL SPECIFICATION	2
MAINTENANCE SPECIFICATION	3
ENGINE	3
CABLE ROUTING	4
PERIODIC INSPECTION AND ADJUSTMENT	5
ENGINE	5
TRANSMISSION OIL LEVEL INSPECTION	5
TRANSMISSION OIL REPLACEMENT	5
CHASSIS	6
PARKING BRAKE ADJUSTMENT	6
CARBURETION	8
CARBURETOR	8
CARBURETOR SETTING CHANGE	8

GENERAL INFORMATION

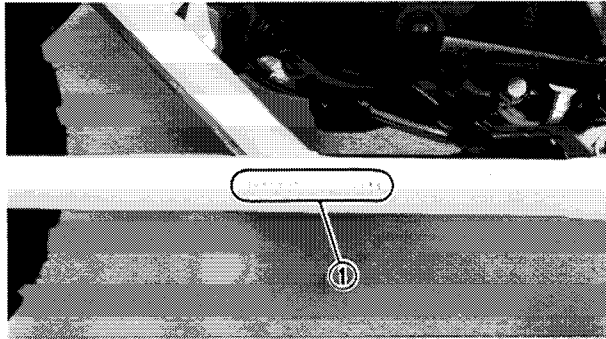

MACHINE IDENTIFICATION

VEHICLE IDENTIFICATION NUMBER (FOR USA, AUS AND CDN)

The vehicle identification number ① is stamped into the left side of the frame.

NOTE:

The vehicle identification number is used to identify your machine and may be used to register your machine with the licensing authority in your state.

Starting Serial Number:

For USA

JY43JMA0 * LC046101

For CDN and AUS

JY43JMW0 * LC075101

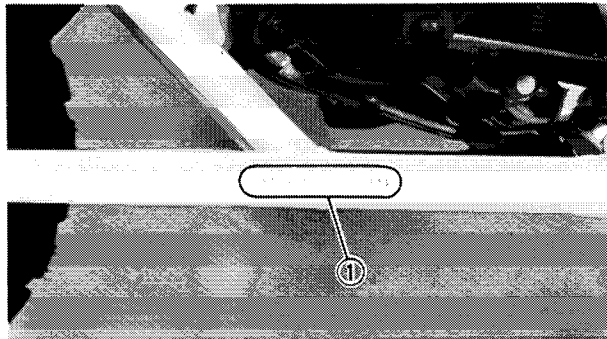

FRAME SERIAL NUMBER

(EXCEPT FOR USA, AUS AND CDN)

The frame serial number ① is stamped into the left side of frame.

NOTE:

The first three digits of these numbers are for model identifications; the remaining digits are the unit production number.

Starting Serial Number:

3JM-075101

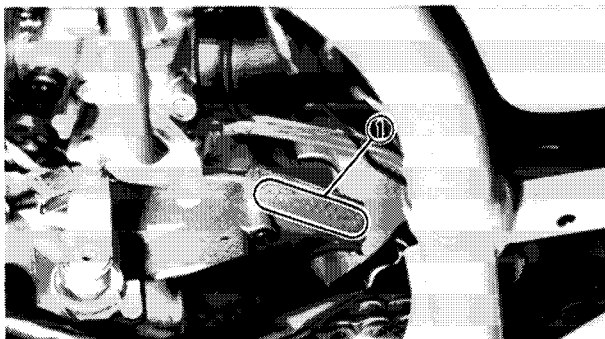

ENGINE SERIAL NUMBER

The engine serial number ① is stamped into the right side of the engine.

NOTE:

The first three digits of these numbers are for model identifications; the remaining digits are the unit production number.

Starting Serial Number:

For USA

3JM-046101

Except for USA

3JM-075101

NOTE:

Designs and specifications are subject to change without notice.



MAINTENANCE SPECIFICATIONS

ENGINE

Model	YFS200A
Carburetor:	
Type/Manufacturer/Quantity	VM26SS/MIKUNI/1
I.D. Mark	2XJ01
Main Jet (M.J.)	# 230
Main Air Jet (M.A.J.)	φ 0.7
Jet Needle-clip Position (J.N.)	5J22-2
Needle Jet (N.J.)	P-6 (# 345)
Cutaway (C.A.)	2.0
Pilot Outlet (P.O.)	0.6
Pilot Jet (P.J.)	# 32.5
Bypass 1 (B.P. 1)	0.8 x 3.75
Pilot Air Screw (P.A.S.)	1 and 1/2 turns out
Valve Seat Size (V.S.)	φ 2.8
Starter Jet (G.S.)	# 45
Float Height (F.H.)	20.0 ~ 21.5 mm (0.79 ~ 0.85 in)
Fuel Level (F.L.)	0.5 ~ 1.5 mm (0.02 ~ 0.06 in)
Engine Idling Speed	1,450 ~ 1,550 r/min



CABLE ROUTING

- ① Clutch cable
- ② Parking brake cable
- ③ Front brake cable
- ④ Throttle switch lead
- ⑤ Throttle cable
- ⑥ Band
- ⑦ Handlebar switch lead (Left)
- ⑧ Voltage regulator lead
- ⑨ Main switch lead
- ⑩ Wire harness
- ⑪ Ground lead

- A For installation of the clutch cable through the guide, route the clutch cable on the left side of the front brake cable.
- B The parking brake cable should be routed behind the front brake cable, and on the right side of the guide.
- C The throttle cable should be routed through the guide behind the clutch cable.
- D Leads should be routed behind the cables.
- E The ground and voltage regulator leads should be routed in front of the cables.

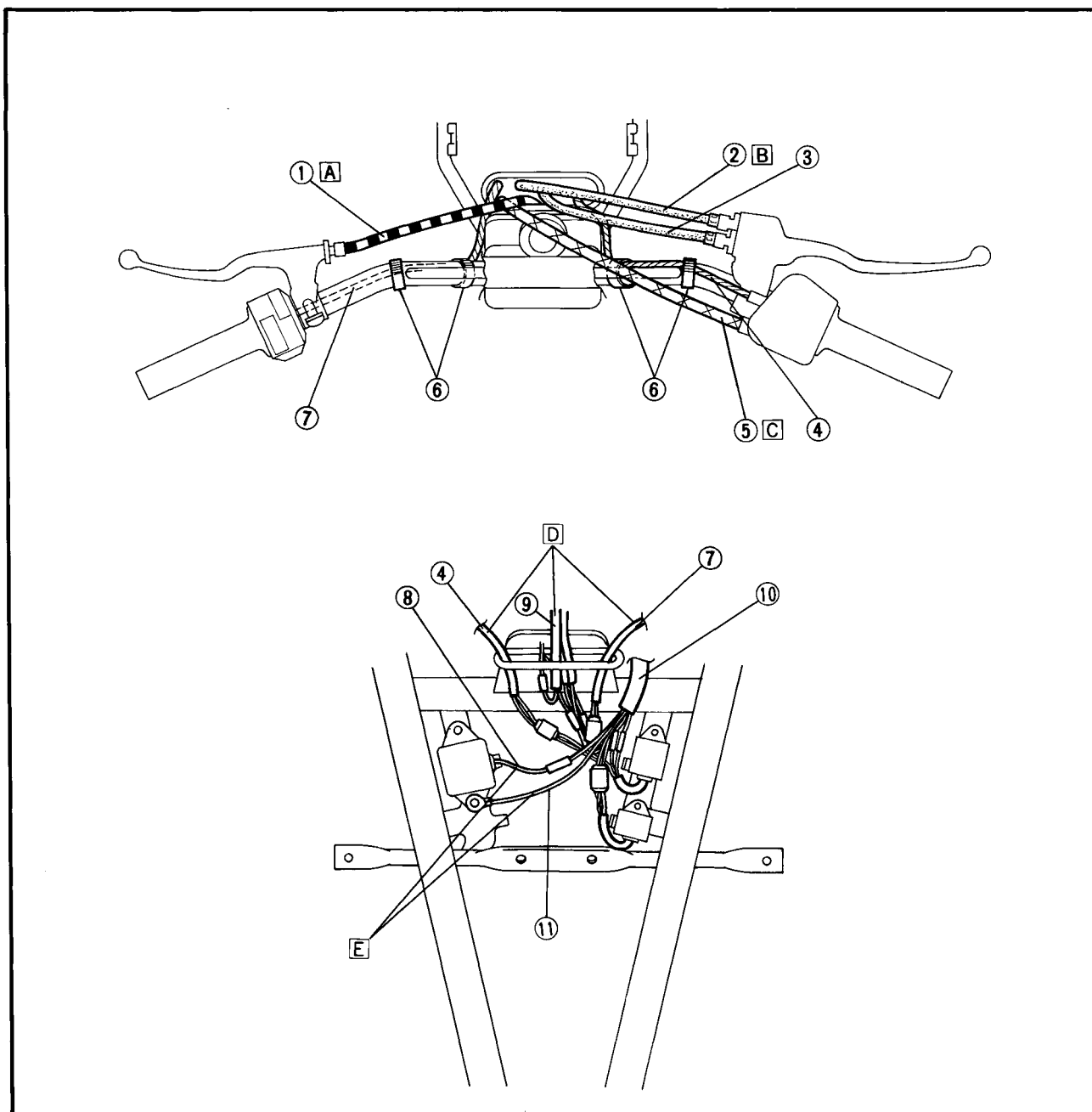



PERIODIC INSPECTION AND ADJUSTMENT

ENGINE

TRANSMISSION OIL LEVEL INSPECTION

1. Inspect:

- Transmission oil level
Oil level low → Add sufficient oil.

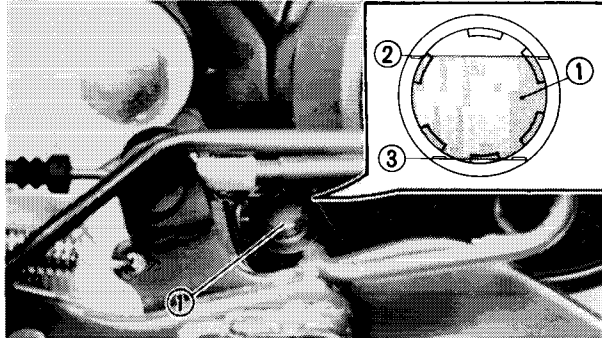

Transmission oil level inspection steps:

- Place the machine on a level place.
- Warm up the engine for several minutes, and stop it.
- Visually check the oil level through the level window ① .

NOTE:

The oil level should be confirmed between maximum ② and minimum ③ marks.

- If the oil level is lower, then add sufficient oil to raise it to the proper level.



Recommended Oil:

Yamalube 4 (10W-30) or SAE
10W30 type SE motor oil.

CAUTION:

- Do not add any chemical additives. Transmission oil also lubricates the clutch and additives could cause clutch slippage.
- Be sure no foreign material enters the crankcase.
- Warm up the engine several minutes, and stop it, then inspect the oil level. If the oil level is lower, perform the aforementioned step again.

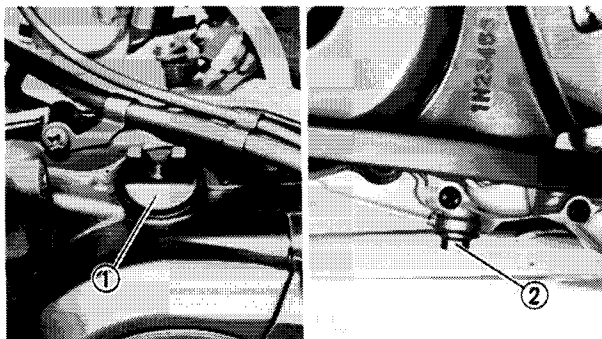

TRANSMISSION OIL REPLACEMENT

1. Place the machine on a level place.
2. Warm up the engine for several minutes, and stop it.
3. Place an oil pan under the engine.
4. Remove:
 - Filler plug ①
 - Drain plug ②Drain the transmission oil.

TRANSMISSION OIL REPLACEMENT/ PARKING BRAKE ADJUSTMENT

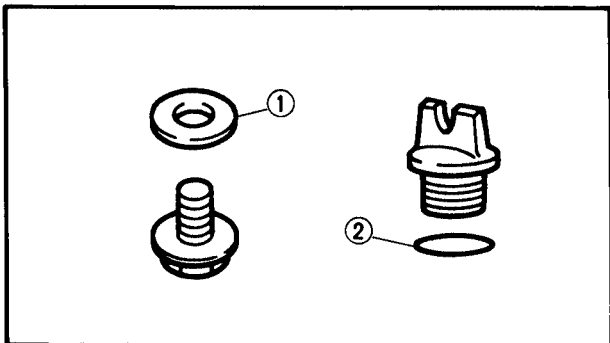

5. Inspect:
- Gasket ① (Drain plug)
 - O-ring ② (Filler plug)
 - Damage → Replace.
6. Tighten:
- Drain plug

 **Drain Plug:**
20 Nm (2.0 m·kg, 14 ft·lb)

7. Fill:
- Crankcase

 **Recommended Oil:**
Yamalube 4 (10W-30) or
SAE 10W30 type SE motor oil

Periodic Oil Change:
0.65 L (0.57 Imp qt, 0.69 US qt)

CAUTION:

- Do not add any chemical additives. Transmission oil also lubricates the clutch and additives could cause clutch slippage.
- Be sure no foreign material enters the crankcase.

8. Install:
- Filler plug
9. Inspect:
- Oil leaks
 - Oil level

NOTE:

- Wipe off any oil spilled on the crankcase.
- Before inspecting the oil level, warm up the engine several minutes and stop it.

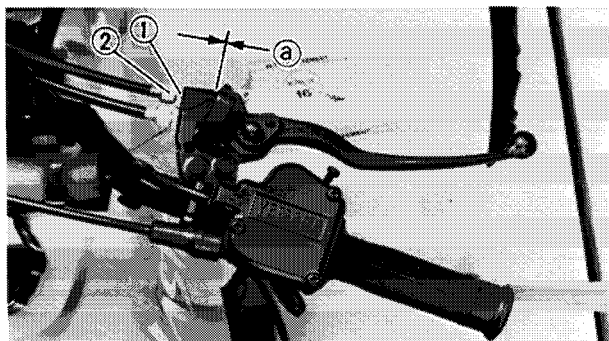

CHASSIS

PARKING BRAKE ADJUSTMENT

1. Check:
- Parking brake cable free play ①
 - Out of specification → Adjust.

 **Parking Brake Cable Free Play:**
Zero mm (Zero in)



2. Adjust:

- Parking brake cable free play

Adjustment steps:

- Loosen the locknut ① .
- Turn the adjuster ② counterclockwise until the parking brake cable free play ③ becomes Zero, or as close to Zero as possible.
- Tighten the locknut ① .

⚠ WARNING

After this adjustment is performed, block the rear of the machine off the ground, and spin the rear wheels to ensure there is no brake drag. If any brake drag is noticed, perform the above steps again.



CARBURETION

CARBURETOR

CARBURETOR SETTING CHANGE

In extremely cold weather, it is necessary to change carburetor setting to maintain optimum engine performance and to prevent engine damage.

1. Remove:

- Carburetor assembly

Refer to "CARBURETOR – REMOVAL" section.

2. Adjust:

- Carburetor setting

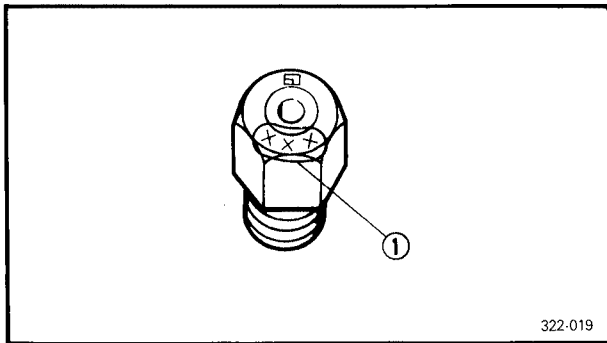

Carburetor setting chart		
Temperature	Main jet	Jet needle
0°C (32°F) above (STD)	#230	2nd groove
+5°C (41°F) ~ -15°C (5°F)	#230	2nd groove
-10°C (14°F) ~ -30°C (-22°F)	#240	3rd groove

① Main jet number

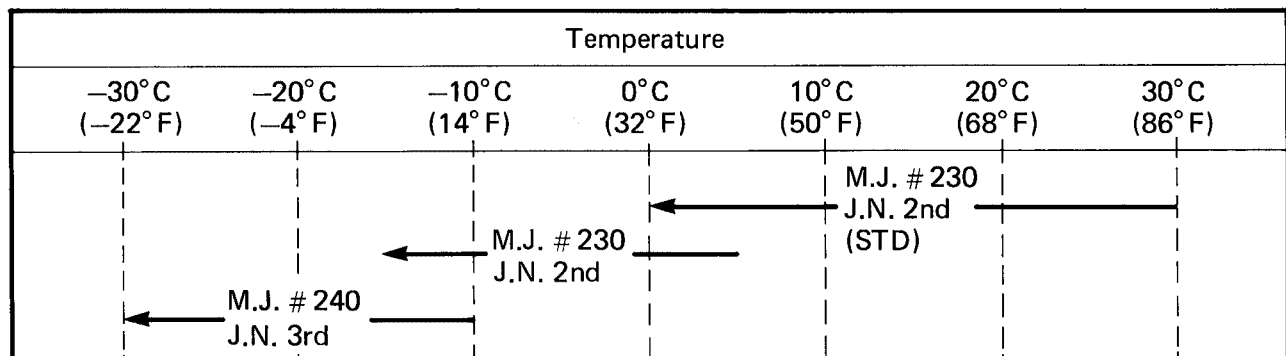

3. Install:

- Carburetor assembly

Refer to "CARBURETOR – INSTALLATION" section.



YAMAHA MOTOR CO., LTD.

IWATA, JAPAN